

Ahşap İşleme Dia (PCD) ve
Elmas Kesici Takımları

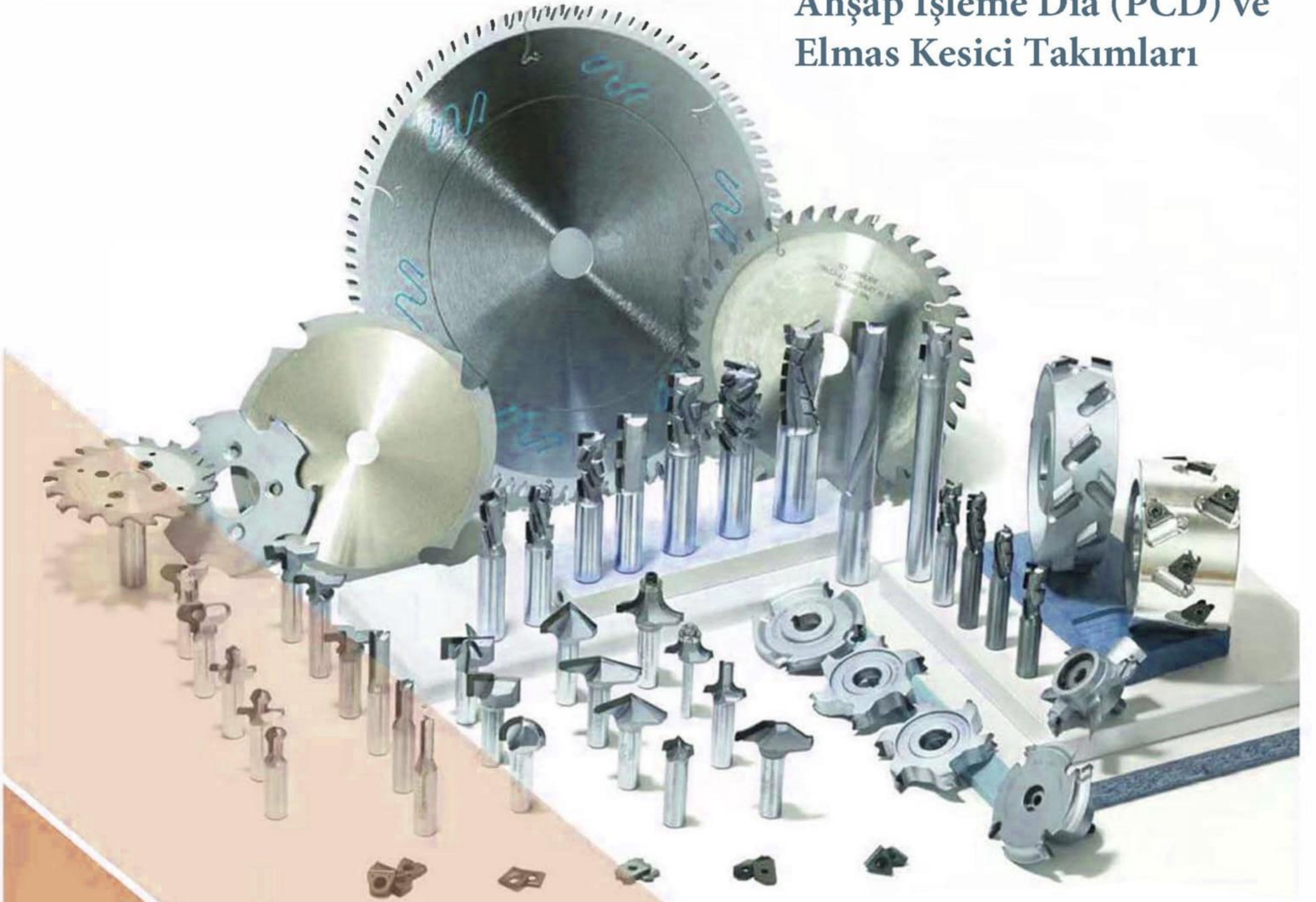

- İkitelli OSB - Aykosan Sanayi Sit. 4lü C Blok
No:83-84 İkitelli/Başakşehir-İstanbul
- +90 (212) 637 0954
- info@mefasbicak.com
- www.mefasbicak.com

Elmas Kesici Takımların Özellikleri

Elmas toz karışımı

Elmas CVD kaplama

Alüminyum alaşımları ve metal olmayan malzemelerin işlenmesi için uygundur

Yeni geliştirilen süper ince kristal elmas kaplama teknolojisi

işleme ömrü kaplamasız bıçaklara göre 80-250 kat daha uzun

PCD Kesici Takımların Ana Performans Göstergeleri

PCD'nin sertliği 8000HV'ye ulaşabilir, bu da sert alaşımların 80-120 katıdır

PCD'nin termal iletkenliği 700W/mk olup, bu da sert alaşımlardan 1,5-9 kat daha yüksektir ve PCBN'den üstündür

Üretim Ürünleri Gösterimi



Dia ISO Uç

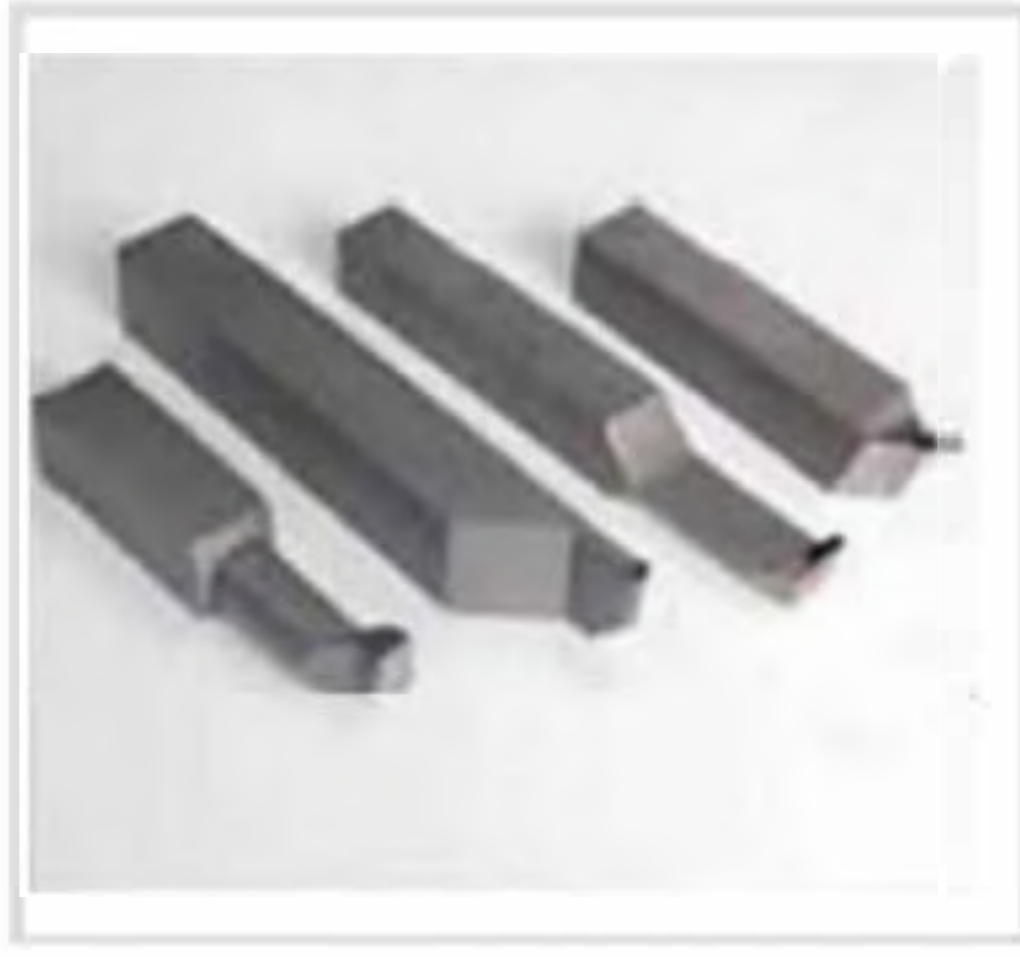

Dia Sert Kesici Aleti



T Tipi Kesici



Dia Konik Matkap



Dia Şamfıraz Kesici



Dia Kazıma Kesici



Elmas Kenar Kesici



Dia Freze Köşe Kesici



**Konik Torna Freze
Kombinasyon Kesici**

PCD Saw Blade

Dia (PCD) Testere

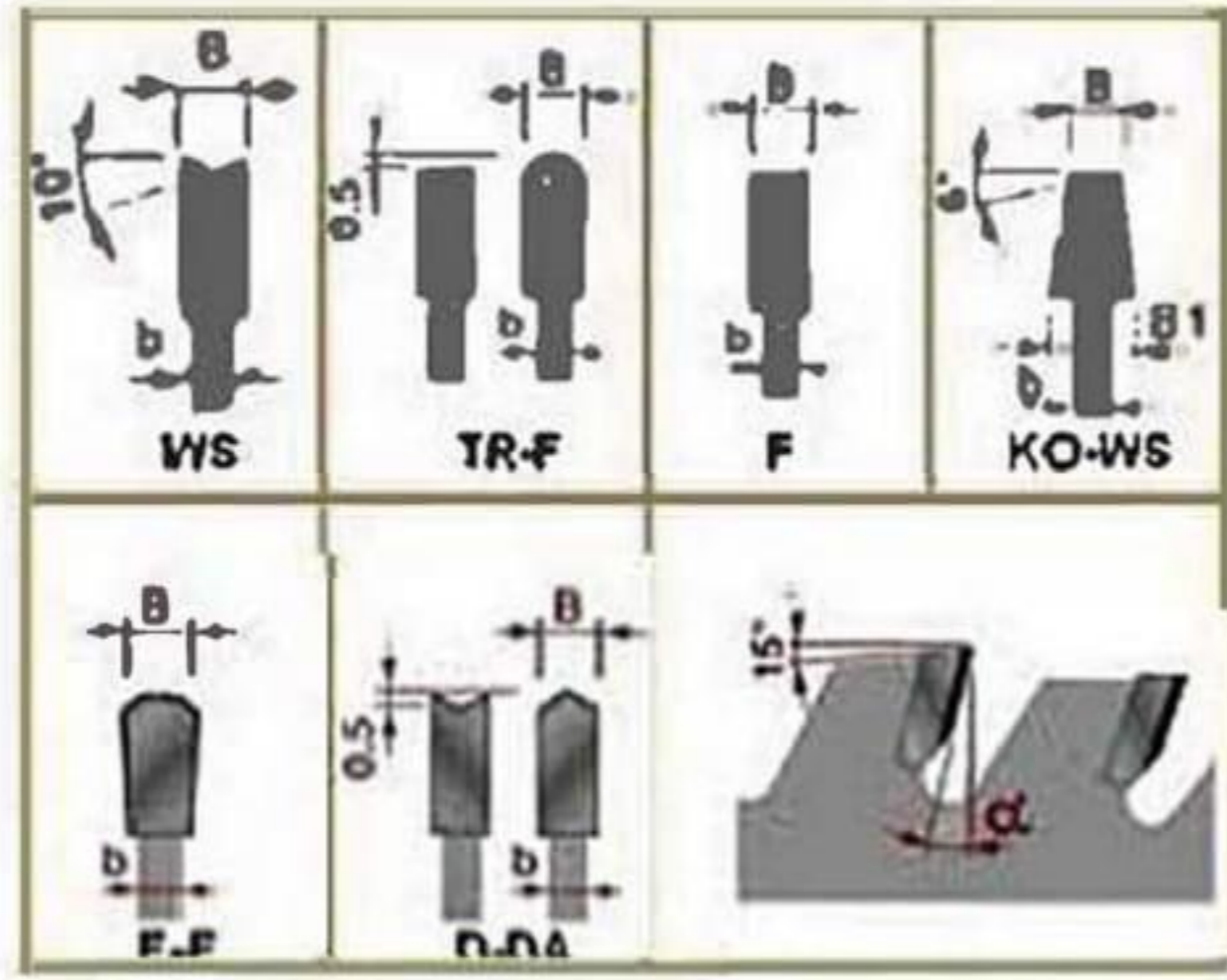

Part NO.	SIZE
ST003101	Ø200X2.2XØ25.4X48T
ST003102	Ø200X2.2XØ25.4X60T
ST003103	Ø250X2.2XØ25.4X60T
ST003104	Ø300X3.0XØ30X60T
ST003105	Ø300X3.0XØ30X72T
ST003106	Ø300X3.0XØ30X96T
ST003107	Ø350X4.4XØ60X72T
ST003108	Ø350X4.0XØ25.4X84T
ST003109	Ø380X4.8XØ60X72T
ST003110	Ø400X4.4XØ30X72T
ST003111	Ø400X4.4XØ60X84T
ST003112	Ø450X4.8XØ60X96T
ST003113	Ø120X2.8\3.6XØ22X(12+12)T
ST003114	Ø180X3.1\4.0XØ25.4X36T
ST003115	Ø180X3.3\4.3XØ25.4X36T
ST003116	Ø180X4.3\5.3XØ45X36T





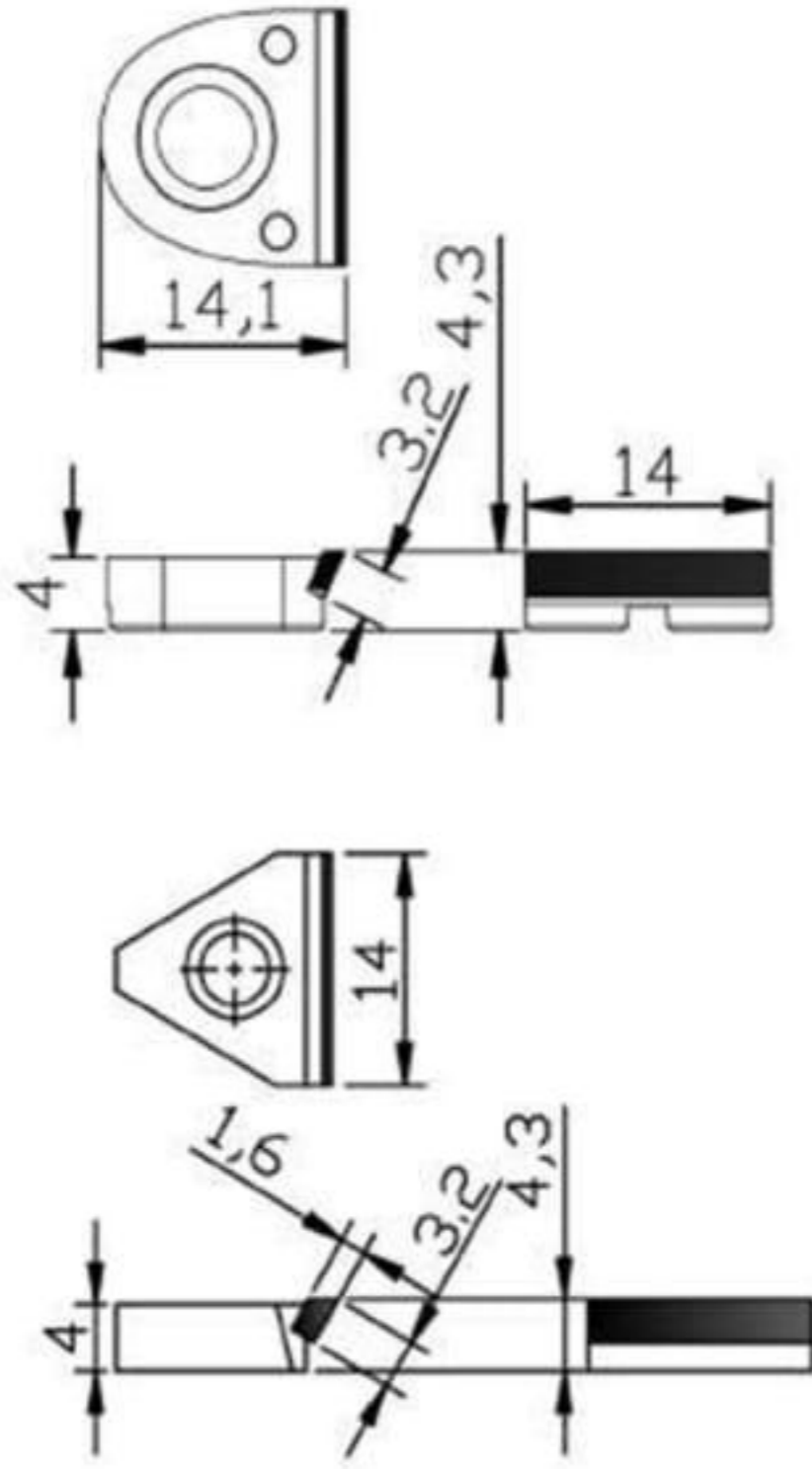

NO	Parça No	Boyut mm	Diş Sayısı	Eğim Açısı
NO.	Part No.	SIZE mm	Z	a°
1	ST006201	50*16*H59 2+2Z	10	30
2	ST006202	60*20*H30 2+2Z	6	30
3	ST006203	60*20*H64 2+2Z	12	30
4	ST006204	60*30*H64 2+2Z	12	30
5	ST006205	70*30*H43 2+2Z	8	30
6	ST006206	70*30*H50 2+2Z	10	30
7	ST006207	70*30*H50 3+3Z	15	30
8	ST006208	70*30*H54 2+2Z	10	30
9	ST006209	70*30*H60 3+3Z	18	30
10	ST006210	80*30*H43 3+3Z	12	30
11	ST006211	80*30*H50 3+3Z	15	30
12	ST006212	80*30*H65 2+2Z	12	30
13	ST006213	80*30*H65 3+3Z	18	30
14	ST006214	100*30*H43 3+3Z	12	30
15	ST006215	100*30*H48 3+3Z	15	30
16	ST006216	100*30*H51 3+3Z	15	30
17	ST006217	100*30*H65 3+3Z	18	30
18	ST006218	100*30*H66 3+3	21	40
19	ST006219	125*30*H32 3+3Z	12	45
20	ST006220	125*30*H32 3+3Z	9	30
21	ST006221	125*30*H43 3+3Z	15	45
22	ST006222	125*30*H43 3+3Z	12	30
23	ST006223	125*30*H48 3+3Z	15	30
24	ST006224	125*30*H55 3+3Z	15	30
25	ST006225	125*30*H65 3+3Z	18	30
26	ST006226	125*30*H65 3+3Z	24	45
27	ST006227	150*30*H43 3+3Z	12	30
28	ST006228	150*30*H43 4+4Z	16	30
29	ST006229	150*30*H50 4+4Z	20	30
30	ST006230	150*30*H55 4+4Z	20	30

PCD Saw Blade

Dia (PCD) Testere

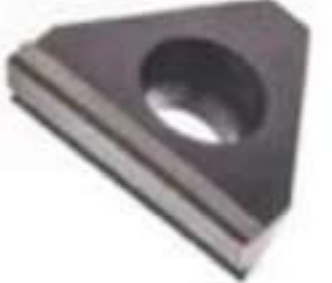

NO	Parça No	Boyut mm	Diş Sayısı	Yarıçap	Malzeme	Fotoğraf
NO.	Part No.	SIZE mm	Z	R	material	
1	ST006001	20x12x2	2	1	HW+PCD	
2	ST006002	20x12x2	2	1.2	HW+PCD	
3	ST006003	20x12x2	2	1.5	HW+PCD	
4	ST006004	20x12x2	2	2	HW+PCD	
5	ST006005	20x12x2	2	2.5	HW+PCD	
6	ST006006	20x12x2	2	3	HW+PCD	
7	ST006007	20x12x2	2	1	PCD	
8	ST006008	20x12x2	2	1.5	PCD	
9	ST006009	20x12x2	2	2	PCD	
10	ST006010-4Z	12*12*2 30°	4		PCD	
11	ST006011-1Z	14x14x2 30°	1		HW+PCD	
12	ST006011-2Z	14x14x2 30°	2		HW+PCD	
13	ST006012-1Z	15x15x2.5 30°	1		HW+PCD	
14	ST006013-2Z	15x15x2.5 30°	2		HW+PCD	
15	ST006014	14x4.3xH3.2	1		HW+PCD	
16	ST006015	14x4.3xH6	1		HW+PCD	
17	ST006016	14x4.3xH3.2	1		HW+PCD	

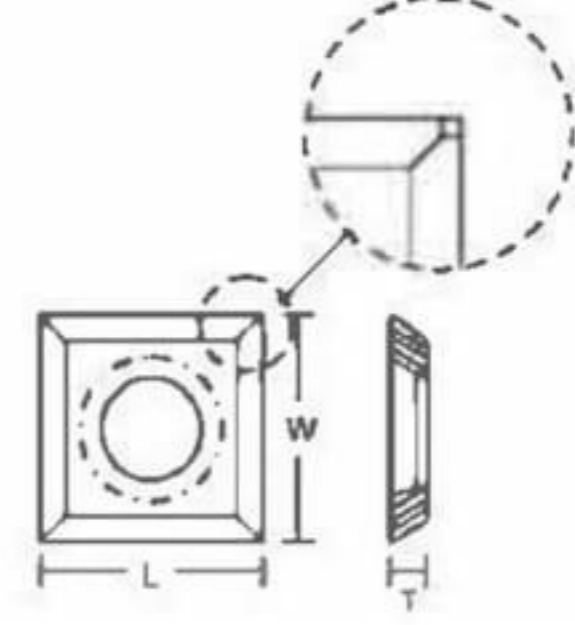
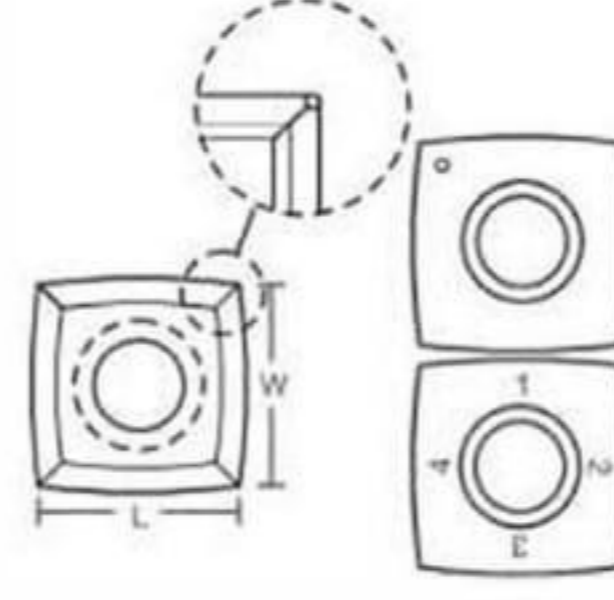

NO	Parça No	Özellikler
1	ST006301	10.5*10.5*1.5-35°
2	ST006302	11*11*2*30°
3	ST006303	12*12*1.5-35°
4	ST006304	12*12*1.5-35° 4-45°
5	ST006305	12*12*2.2-35°
6	ST006306	14*14*1.2-30°
7	ST006307	14*14*2-30°
8	ST006308	14*14*2.5-30°
9	ST006309	14.3*14.3*2.5-30°
10	ST006310	14.3*14.3*2.5-35°
11	ST006311	14.6*14.6*2.5-30°
12	ST006312	15*15*2.5-30°
13	ST006313	15*15*2.5-30° 4R0.5
14	ST006314	15*15*2.5-37° /35°
15	ST006315	17*17*2-35°
16	ST006316	18*18*1.95
17	ST006317	18*18*2.45
18	ST006318	18*18*2.95
19	ST006319	11*11*2*30° R50
20	ST006320	14*14*2-30° R150
21	ST006321	15*15*2.5-30°R50
22	ST006322	15*15*2.5-30°R100
23	ST006323	15*15*2.5-30°R150
24	ST006324	14.6*14.6*2.5-30° R150 4 R0.5



NO	Parça No	Özellikler	Açıklama
1	ST006401	7.5*12*1.5-35°	
2	ST006402	9.6*12*1.5-35°	
3	ST006403	15*12*1.5-35°	
4	ST006404	14.3*14.3*2-50° 两刃	
5	ST006405	20*12*1.5-35°	
6	ST006406	22*19*2-30°	
7	ST006407	25*12*1.5-35° 单孔	
8	ST006408	25*12*1.5-35° 单孔(四刃)	
9	ST006409	29.5*12*1.5-35° 四刃	
10	ST006410	30*12*1.5-35°	
11	ST006411	30*12*1.5-35° 倒四角4-3°	
12	ST006412	30*12*2.5-35°	
13	ST006413	40*12*1.5-35°	
14	ST006414	49.2*12*1.5-35° 四刃	
15	ST006415	50*12*1.5-35° 2BORE	
16	ST006416	50*12*1.5-35° 3BORE	
17	ST006417	60*12*1.5-35°	

ROUGH/FINE TRIMMING CUTTERS



PART NO.	SIZE	ØD	Ød	H	Z
ST4032706-J	56*16*14*4Z	56	16	14	4
ST4032060-J	69*16*13*4Z	69	16	13	4
ST6032060J	69*16*13*6Z	69	16	13	6
ST3038650-J	70*16*3Z	70	16		3
ST4035049-N	75*20*4Z	75	20		4
ST4035050-N	75*20*4Z	75	20		4
ST6035048-N	80*20*6Z	80	20		6
ST6035049-N	75*20*6Z	75	20		6
ST6035050-N	75*20*6Z	75	20		6
ST6048496A-N	68*16*H16*6Z	68	16	16	6
ST6047332-N	68*16*H16*6Z	68	16	16	6

PRE-MILLING CUTTERS

Dia (PCD) Ön Temizleme Topu



PART NO.	SIZE	ØD	Ød	H	Z
ST-Y08035	80*35*20 Z=3+3	80	20	35	3+3
ST-Y08050	80*50*20 Z=3+3	80	20	50	3+3
ST-Y08065	80*65*20 Z=3+3	80	20	65	3+3
ST-Y12043	120*43*30 Z=3+3	120	30	43	3+3
ST-Y10035	100*35*30 Z=3+3	100	30	35	3+3
ST-Y10048	100*48*30 Z=3+3	100	30	48	3+3
ST-Y10065	100*65*30 Z=3+3	100	30	65	3+3
ST-Y12534	125*34*30 Z=3+3	125	30	34	3+3
ST-Y12543	125*43*30 Z=3+3	125	30	43	3+3
ST-Y12563	125*63*30 Z=3+3	125	30	63	3+3
ST-Y12535	125*35*30 Z=3+3	125	30	35	3+3
ST-Y12565	125*65*30 Z=3+3	125	30	65	3+3
ST-Y15035	150*35*30 Z=4+4	150	30	35	3+3
ST-Y15046	150*46*30 Z=3+3	150	30	46	3+3
ST-Y15065	150*65*30 Z=3+3	150	30	65	3+3
ST-Y15065B	150*65*30 Z=4+4	150	30	65	4+4

EDGE BEVEL CUTTER

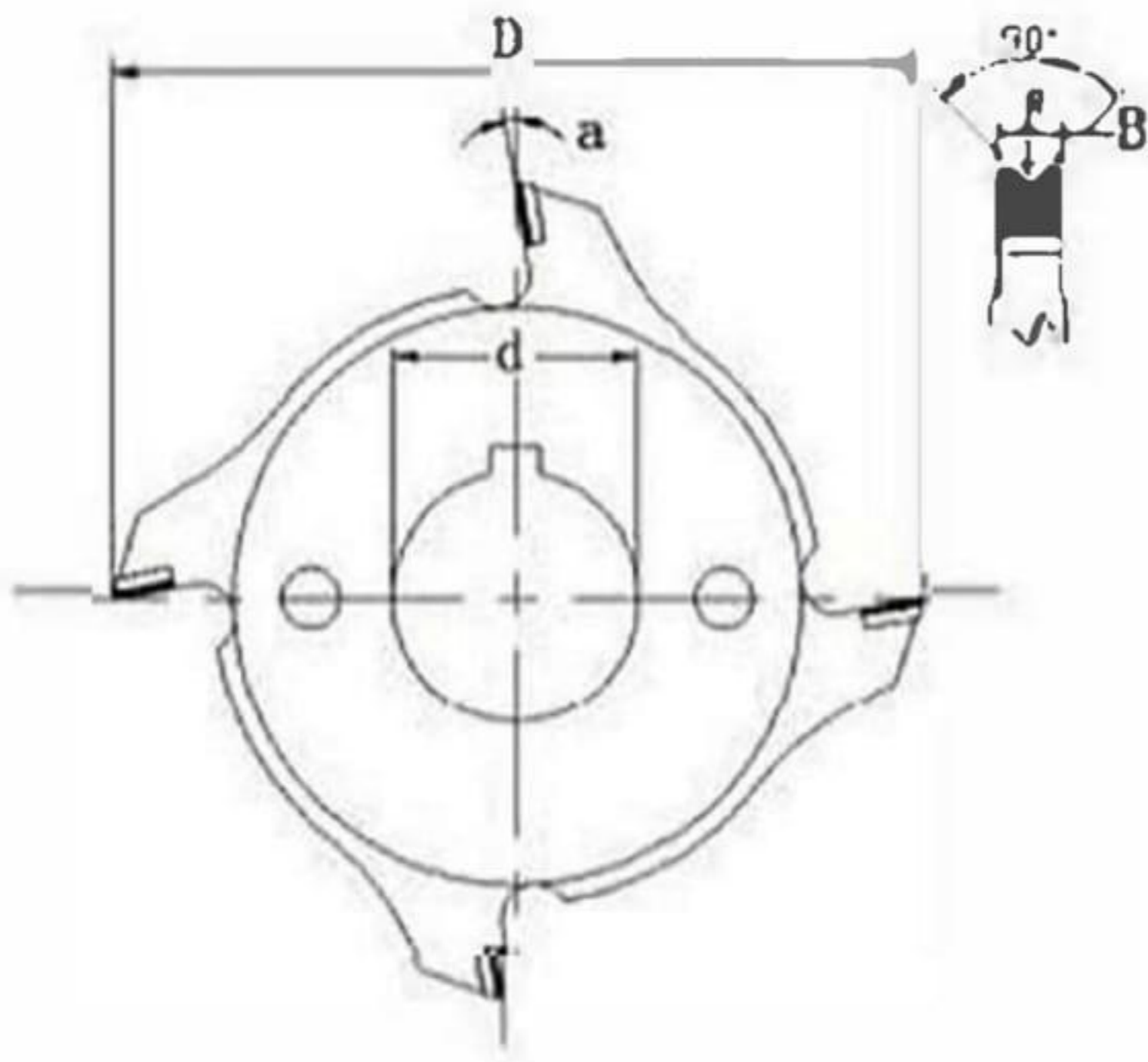

Part NO	ØD	Ød	B	Z	R
ST002201	83	25.4	5	3	0.2/0.5/1.0
ST002202	83	25.4	5	4	0.2/0.5/1.0
ST002203	83	25.4	5	6	0.2/0.5/1.0
ST002204	83	25.4	5	8	0.2/0.5/1.0
ST002205	83	25.4	5	12	0.5
ST002208	87	25.4	5	3	0.2/0.5/1.0
ST002207	87	25.4	5	4	0.2/0.5/1.0
ST002208	87	25.4	5	6	0.2/0.5/1.0

Dia Router Cutters



**Diamond
Performance
Router**



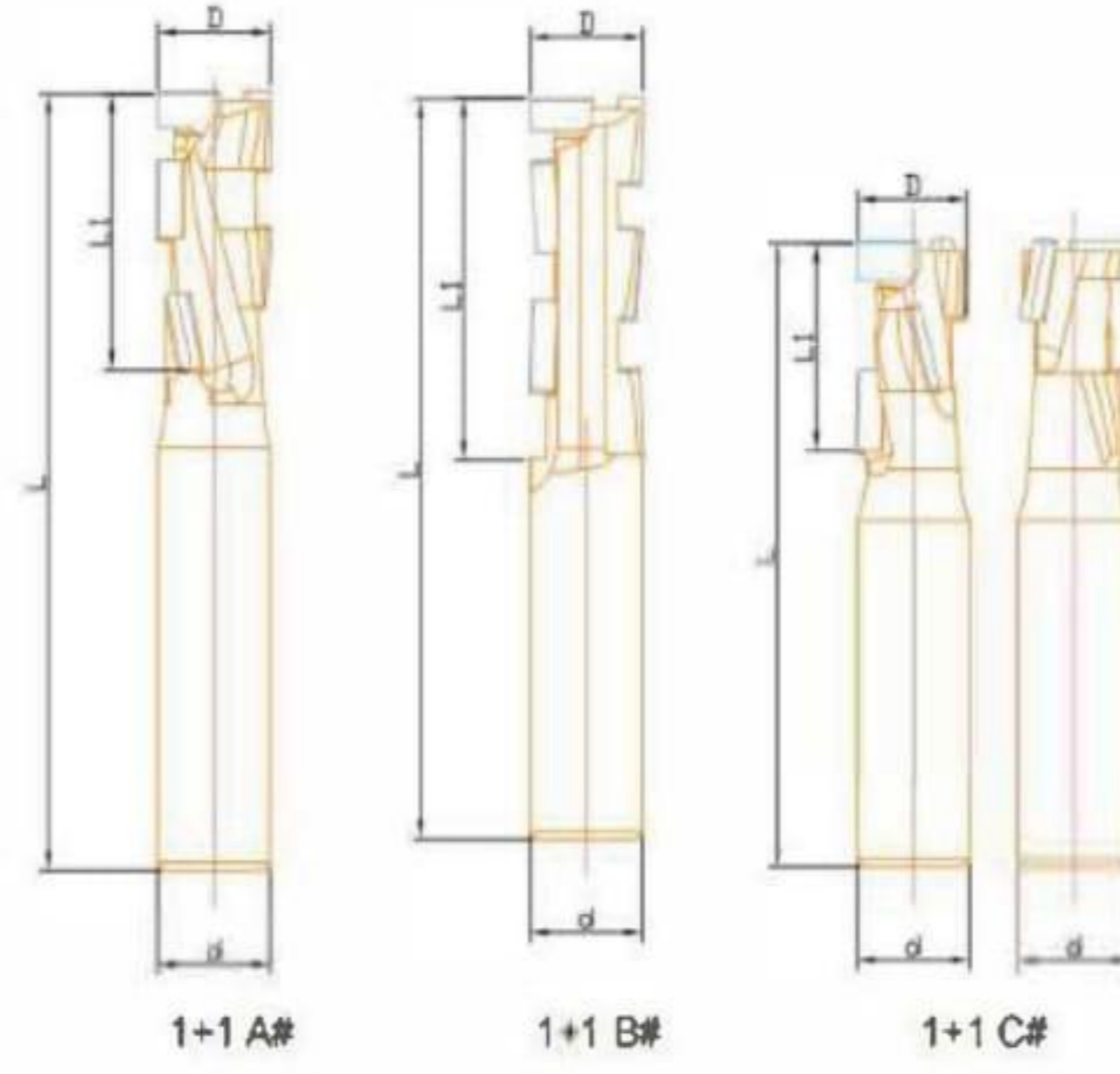

Elmas CNC freze ucu 1+1Z

Diamond Shank-Type cutter 1+1Z

NO	Parça No	BOYUT mm	Sap Çapı	Bıçak Çapı	Bıçak Uzunluk	Toplam Uzunluk	Dış Sayısı
NO.	Part No.	SIZE mm	Ød SHK	ØD ÇEŞ	L1 CEL	OVL	Z
1	ST0013-D8 H22 S8	8*6*22* L 68	8	6	22	L 68	1+1
2	ST0013-D8 H22 S12.7	12.7*8*22* L 70	12.7	8	22	L 70	1+1
3	ST0013-D10 H22 S12.7	12.7*10*22* L 70	12.7	10	22	L 70	1+1
4	ST0013-D10 H27 S12.7	12.7*10*27* L 75	12.7	10	27	L 75	1+1
5	ST0013-D12.7 H25 S12.7	12.7*12.7*25* L 70	12.7	12.7	25	L 70	1+1
6	ST0013-D12.7 H30 S12.7	12.7*12.7*30* L 75	12.7	12.7	30	L 75	1+1
7	ST0013-D12 H27	12*12*27* L 75	12	12	27	L 75	1+1
8	ST0013-D12 H25.4	12*12*25.4* L 75	12	12	25.4	L 75	1+1
9	ST0013-D12 H30	12*12*30* L 80	12	12	30	L 80	1+1
10	ST0013-D12 H35	12*12*35* L 85	12	12	35	L 85	1+1
11	ST0013-D12 H43	12*12*43* L 95	12	12	43	L 95	1+1
12	ST0013-D12 H50	12*12*50* L 110	12	12	50	L 110	1+1
13	ST0013-D16 H25	16*16*25* L 85	16	16	25	L 85	1+1
14	ST0013-D16 H30	16*16*30* L 90	16	16	30	L 90	1+1
15	ST0013-D16 H35	16*16*35* L 95	16	16	35	L 95	1+1
16	ST0013-D16 H43	16*16*43* L 100	16	16	43	L 100	1+1
17	ST0013-D16 H45	16*16*45* L 100	16	16	45	L 100	1+1
18	ST0013-D16 H50	16*16*50* L 100	16	16	50	L 100	1+1
19	ST0013-D18 H35 S16	16*18*35* L 100	16	18	35	L 100	1+1
20	ST0013-D18 H45 S16	16*18*45* L 100	16	18	45	L 100	1+1
21	ST0013-D18 H65 S16	16*18*65* L 100	16	18	65	L 100	1+1
22	ST0013-D16 H25 S20	20*16*25* L 110	20	16	25	L 110	1+1
23	ST0013-D16 H35 S20	20*16*35* L 95	20	16	35	L 95	1+1
24	ST0013-D16 H43 S20	20*16*43* L 103	20	16	43	L 103	1+1
25	ST0013-D18 H25 S20	20*18*25* L 95	20	18	25	L 95	1+1
26	ST0013-D18 H35 S20	20*18*35* L 105	20	18	35	L 105	1+1
27	ST0013-D18 H43 S20	20*18*43* L 115	20	18	43	L 115	1+1
28	ST0013-D25 H43 S25	25*25*65* L 115	25	25	65	L 115	1+1

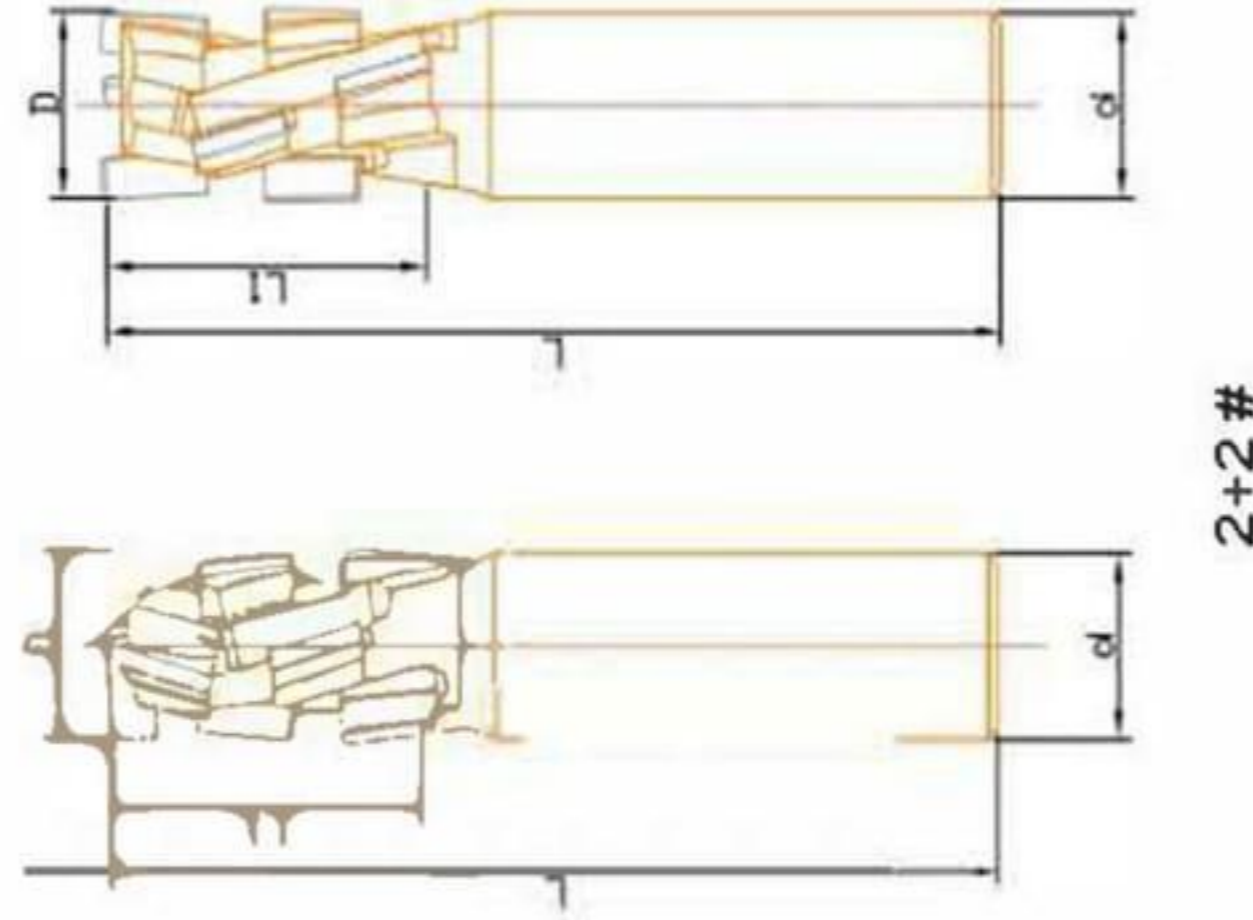

Ahşap İşleme PCD Takımları 2+2Z Diamond Shank-Type cutter 2+2Z

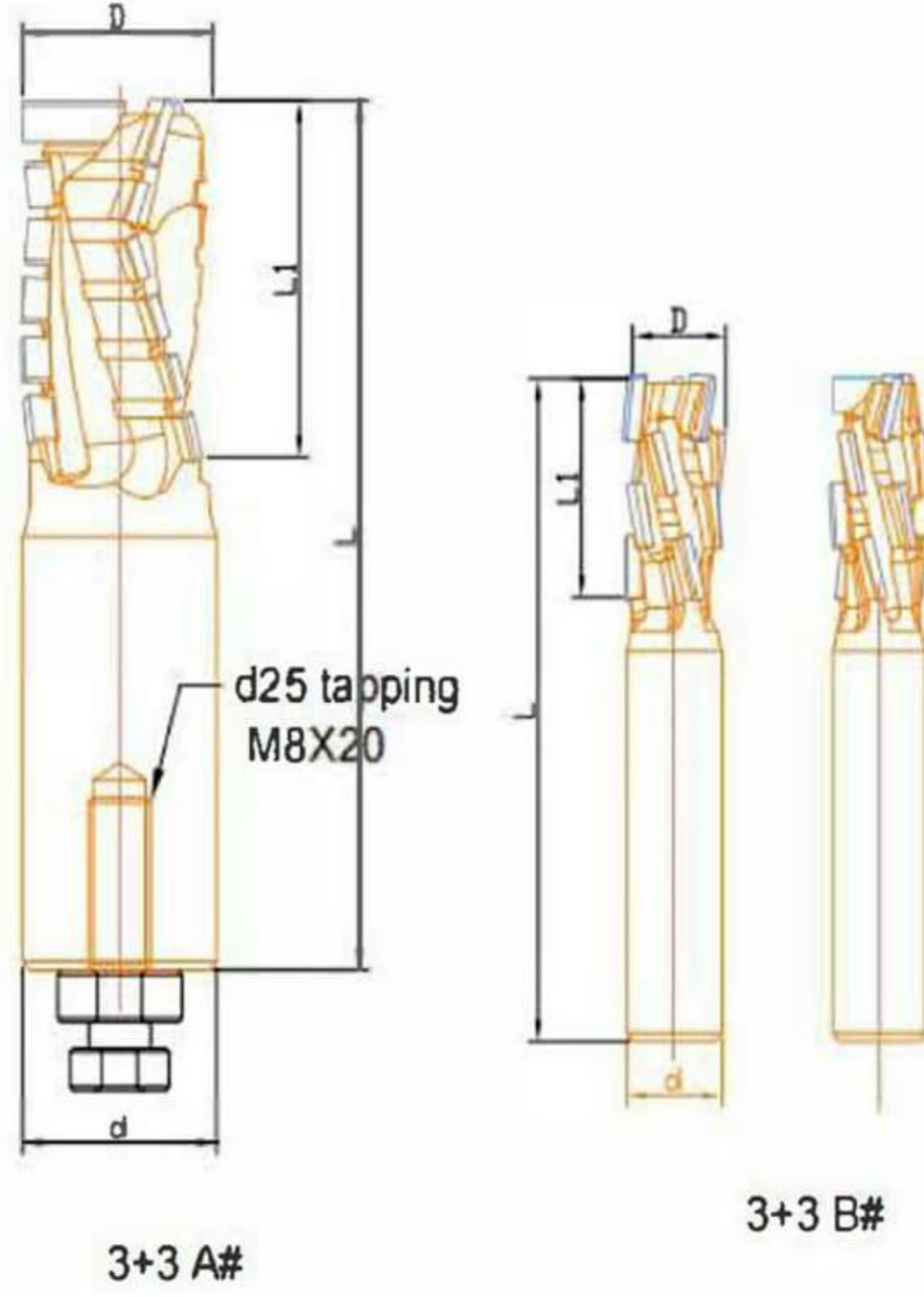
No.	Parça No.	Boyut mm	Sap Çapı	Biçak Çapı	Biçak Uzunluk	Toplam Uzunluk	Diş Sayısı
NO.	Part No.	SIZE mm	Ød	SHK	ØD CEL	OV L	Z
1	ST0012-D10 H22	12*10*25* L 75	12	10	25	L 75	2+2
2	ST0012-D12 H25	12*12*25* L 75	12	12	25	L 75	2+2
3	ST0012-D12 H30	12*12*30* L 80	12	12	30	L 80	2+2
4	ST0012-D16 H25	16*16*25*L85	16	16	25	L85	2+2
5	ST0012-D16 H30	16*16*30*L90	16	16	30	L90	2+2
6	ST0012-D16 H35	16*16*35*L90	16	16	35	L90	2+2
7	ST0012-D16 H38	16*16*38*L90	16	16	38	L90	2+2
8	ST0012-D18 H38 S16	16*18*38*L90	16	18	38	L90	2+2
9	ST0012-D20 H28	20*20*28*L90	20	20	28	L90	2+2
10	ST0012-D20 H35	20*20*35*L105	20	20	35	L105	2+2
11	ST0012-D20 H43	20*20*43*L105	20	20	43	L105	2+2
12	ST0012-D16 H38 S25	25*16*38*L100	25	16	38	L100	2+2
13	ST0012-D20 H30 S25	25*20*30*L100	25	20	30	L100	2+2
14	ST0012-D20 H38 S25	25*20*38*L105	25	20	38	L105	2+2
15	ST0012-D25 H35	25*25*35*L100	25	25	35	L100	2+2
16	ST0012-D25 H48	25*25*48*L115	25	25	48	L115	2+2

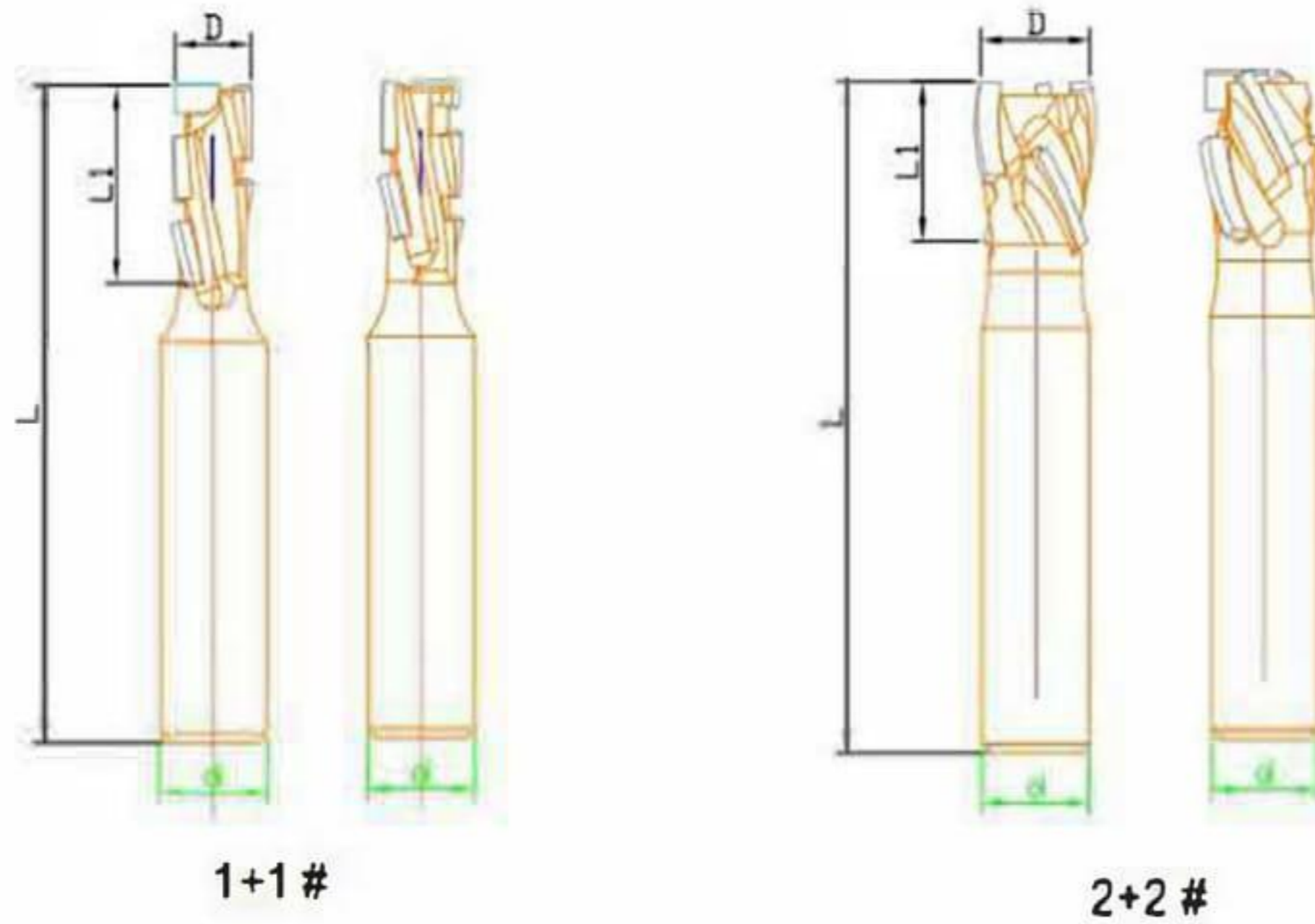

Ahşap İşleme PCD Takımları 3+3Z Diamond Shank-Type cutter 3+3Z

NO	Sipariş No	Boyut mm	Sap Çapı	Bıçak Çapı	Bıçak Uzunluk	Toplam Uzunluk	Diş Sayısı
NO.	Order No.	SIZE mm	Ød SHK	ØD CED	L1 CEL	OVL	Z
1	ST0011 D10 H22	12*10*22*L70	12	10	22	L70	3+3
2	ST0011 D12 H25	12*12*25*L75	12	12	25	L75	3+3
3	ST0011 D12 H28	12*12*28*L75	12	12	28	L75	3+3
4	ST0011 D12 H32	12*12*32*L85	12	12	32	L85	3+3
5	ST0011 D12 H32	12*12*41*L90	12	12	41	L90	3+3
6	ST0011 D16 H25	16*16*25*90	16	16	25	90	3+3
7	ST0011 D16 H30	16*16*30*95	16	16	30	95	3+3
8	ST0011 D16 H35	16*16*35*95	16	16	35	95	3+3
9	ST0011 D16 H38	16*16*38*100	16	16	38	100	3+3
10	ST0011 D16 H45	16*16*45*L100	16	16	45	L100	3+3
11	ST0011 D20 H28	20*20*28*L90	20	20	28	L90	3+3
12	ST0011 D20 H35	20*20*35*L95	20	20	35	L95	3+3
13	ST0011 D20 H45	20*20*45*L105	20	20	45	L105	3+3
14	ST0011 D18 H22 S25	25*18*22*L100	25	18	22	L100	3+3
15	ST0011 D20 H28 S25	25*20*28*L107	25	20	28	L107	3+3
16	ST0011 D25 H28	25*25*28*L115	25	25	28	L115	3+3
17	ST0011 D25 H35	25*25*35*L105	25	25	35	L105	3+3
18	ST0011 D25 H42	25*25*42*L125	25	25	42	L125	3+3
19	ST0011 D25 H48	25*25*48*L125	25	25	48	L125	3+3
20	ST0011 D25 H55	25*25*55*L120	25	25	55	L120	3+3
21	ST0011 D25 H60	25*25*60*L130	25	25	60	L130	3+3



ST0019 SERIES

Ahşap işleme PCD Takımları - Diamond Shank-Type Grooving cutter

NO	Sipariş No	Boyut mm	Sap Çapı	Bıçak Çapı	Bıçak Uzunluk	Toplam Uzunluk	Diş Sayısı
NO.	Order No.	SIZE mm	Ød SHK	ØD CED	L1 CEL	OVL	Z
1	ST0019 D6 H12 S6	6*6*12*L55	6	6	12	L55	1+1
2	ST0019 D8 H22 S12.7	12.7*8*22*L70	12.7	8	22	L70	1+1
3	ST0019 D9 H15 S12.7	12.7*9*15*L70	12.7	9	15	L70	1+1
4	ST0019 D9.1 H20 S12.7	12.7*9.1*20*L75	12.7	9.1	20	L75	1+1
5	ST0019 D10 H22 S12.7	12.7*10*22*L70	12.7	10	22	L70	1+1
6	ST0019 D12 H22 S12	12*12*22*L90	12	12	22	L90	1+1
7	ST0019 D10 H16 S12.7	12.7*10*16*L60	12.7	10	16	L60	2+2
8	ST0019 D12 H15 S12.7	12.7*12*15*L70	12.7	12	15	L70	2+2
9	ST0019 D13 H15 S12.7	12.7*13*15*L70	12.7	13	15	L70	2+2
10	ST0019 D13 H15 S12.7	12.7*14*15*L70	12.7	14	15	L70	2+2
11	ST0019 D15 H15 S12.7	12.7*15*15*L70	12.7	15	15	L70	2+2
12	ST0019 D18.5 H15 S12.7	12.7*18.5*15*L70	12.7	18.5	15	L70	2+2
13	ST0019 D18.5 H22 S12.7	12.7*18.5*22*L75	12.7	18.5	22	L75	2+2
14	ST0019 D22 H22 S12.7	12.7*22*15*L70	12.7	22	15	L70	2+2

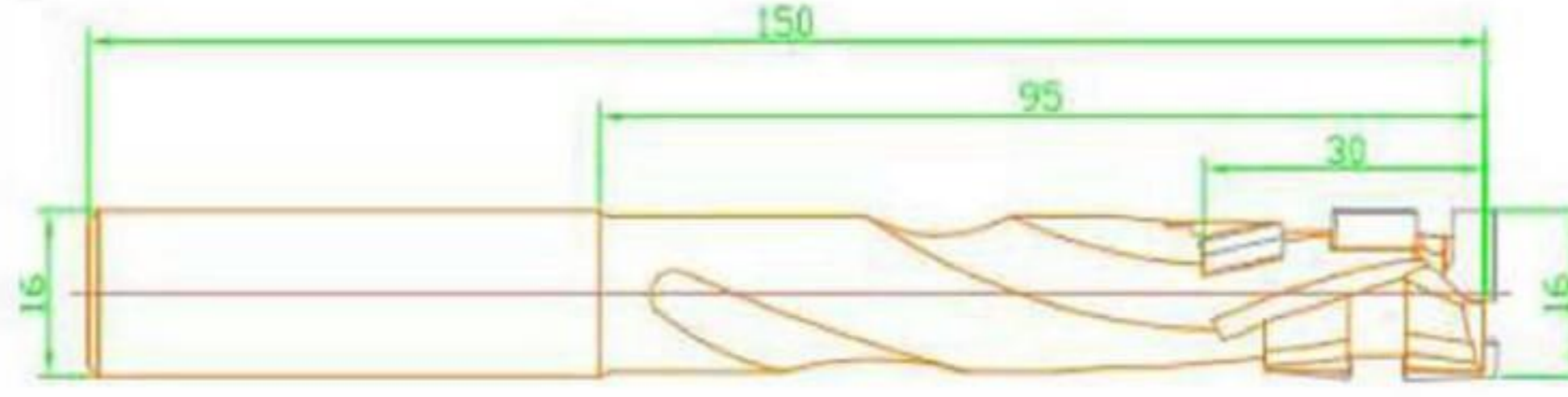

16XØ16XH30*W150=Z1+1

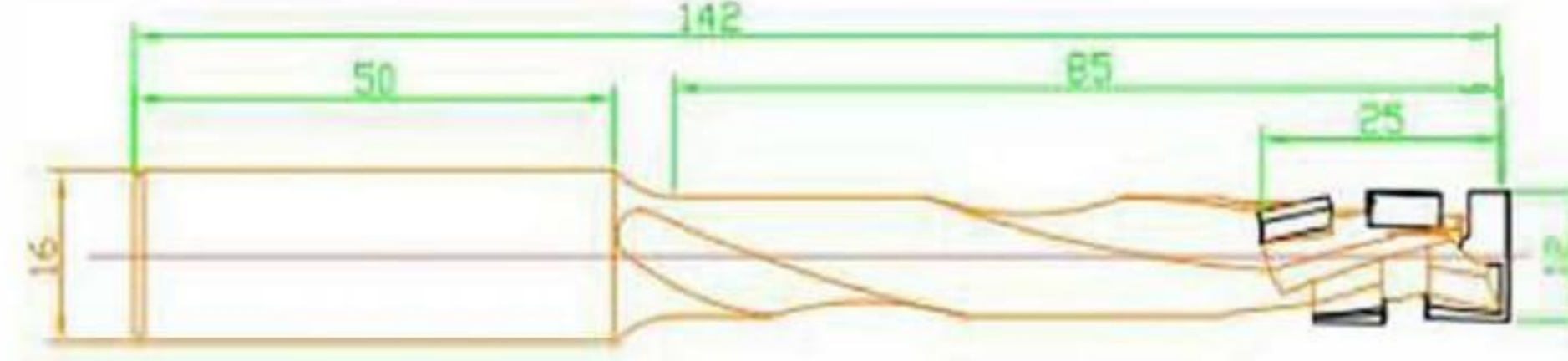

Ahşap İşleme PCD Takımları Diamond Shank-Type Lock-Case cutter

NO	Sipariş No	Boyut mm	Sap Çapı	Bıçak Çapı	Bıçak Uzunluk	Toplam Uzunluk	Diş Sayısı
NO.	Order No.	SIZE mm	Ød SHK	ØD	L1 CEL	OVL	Z
1	ST0013L D12 H25 S12	12*12*25*L120	12	12	25	L120	1+1
2	ST0013L D12 H25 S16	16*12*25*L142	16	12	25	L142	1+1
3	ST0013L D16 H30 S16	16*16*30*L165	16	16	30	L165	1+1
4	ST0013L D18 H35 S16	16*18*35*L165	16	18	35	L165	1+1

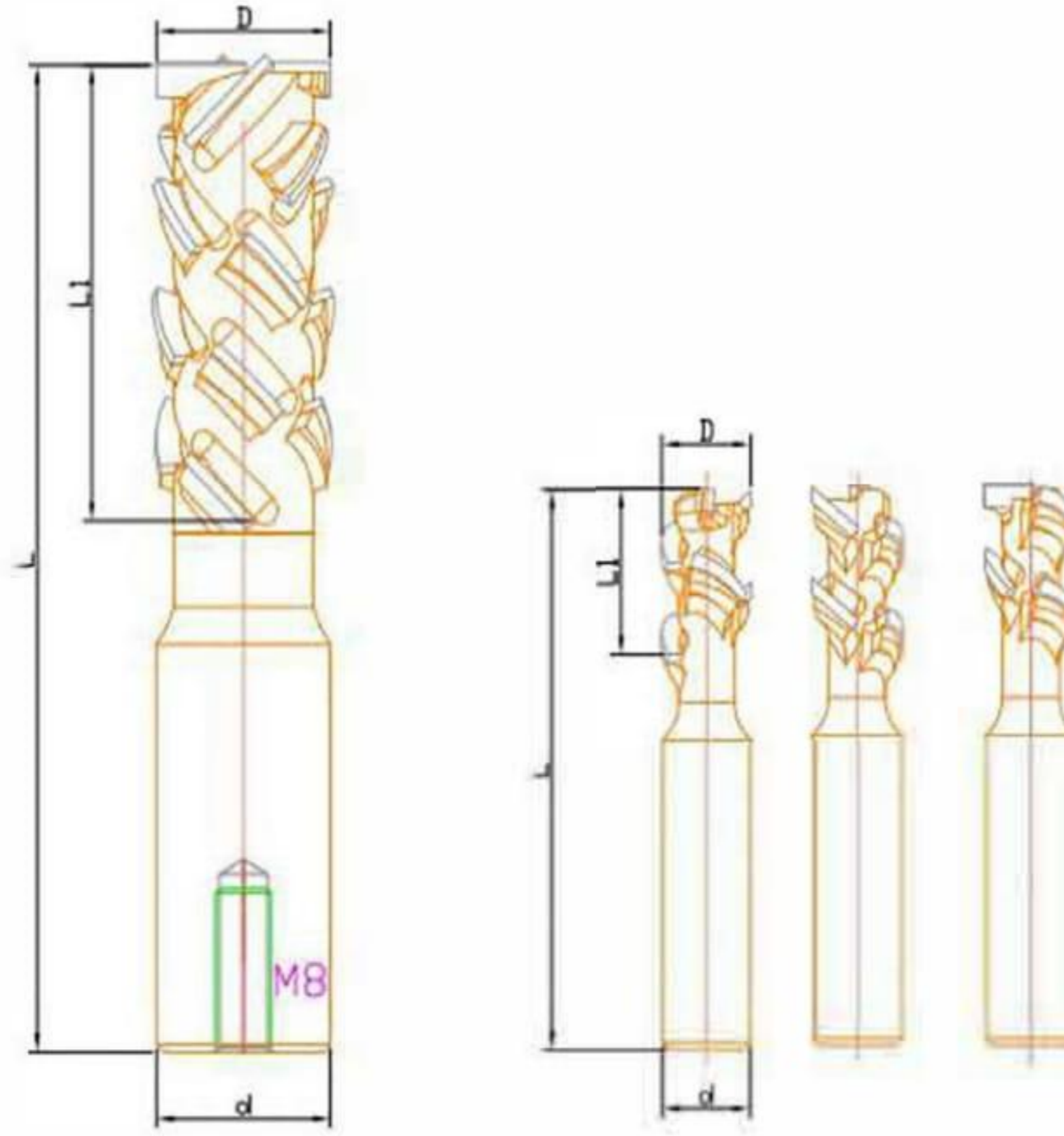

ST0020SERIES

Ahşap İşleme PCD Takımları Diamond Shank-Type Large spiral cutter

NO	Sipariş Numarası	Boyut mm	Sap Çapı	Bıçak Çapı	Bıçak Uzunluk	Toplam Uzunluk	Diş Sayısı
NO.	Order No.	SIZE mm	Ød SHK	ØD	L1 CEL	OVL	Z
1	ST0020 D12 H25 S12	12*12*25*L80	12	12	25	L80	1+1
2	ST0020 D12 H18 S12.7	12.7*12*18*L75	12.7	12	18	L75	1+1
3	ST0020 D13 H14 S12.7	12.7*13*14*L75	12.7	13	14	L75	1+1
4	ST0020 D13 H22 S12.7	12.7*13*22*L75	12.7	13	22	L75	1+1
5	ST0020 D16 H29.2	16*16*29.2*L90	16	16	29.2	L90	1+1
6	ST0020 D16 H30	16*20*30*L90	16	20	30	L90	2+2
7	ST0020 D20 H50 S25	20*25*50*L120	20	25	50	L120	2+2
8	ST0020 D25 H60 S25	25*25*60*L130	25	25	60	L130	2+2

T007 V-Series, 3Z Nano coating, straight
V-Serisi, 3Z Nano Kaplama Elmas Freze



Note:
All products are
3 nm superhard
coating

NO	Parça No	Boyut mm	Sap Çapı	Bıçak Çapı	Bıçak Uzunluk		Diş Sayısı
NO.	Part No.	SIZE mm	Ød SHK	ØD CED	L1		Z
1	T007-V0620	1/2*6 *20	12.7	6	20		3
2	T007-V0622	1/2*6 *22	12.7	6	22		3
3	T007-V0625	1/2*6 *25	12.7	6	25		3
4	T007-V0628	1/2*6 *28	12.7	6	28		3
5	T007-V0630	1/2*6 *30	12.7	6	30		3
6	T007-V0820	1/2*8 *20	12.7	8	20		3
7	T007-V0822	1/2*8 *22	12.7	8	22		3
8	T007-V0825	1/2*8 *25	12.7	8	25		3
9	T007-V0828	1/2*8 *28	12.7	8	28		3
10	T007-V0830	1/2*8 *30	12.7	8	30		3
11	T007-V0832	1/2*8 *32	12.7	8	32		3
12	T007-V0830	1/2*8 *35	12.7	8	35		3
13	T007-V1020	1/2*10 *20	12.7	10	20		3
14	T007-V1023	1/2*10 *23	12.7	10	23		3
15	T007-V1025	1/2*10 *25	12.7	10	25		3
16	T007-V1028	1/2*10 *28	12.7	10	28		3
17	T007-V1030	1/2*10 *30	12.7	10	30		3
18	T007-V1033	1/2*10 *33	12.7	10	33		3
19	T007-V1035	1/2*10 *35	12.7	10	35		3
20	T007-V1040	1/2*10 *40	12.7	10	40		3
21	T007-V1050	1/2*10 *50	12.7	10	50		3
22	T007-V1225	1/2x12x25	12.7	12.00	25		3
23	T007-V1230	1/2x12x30	12.7	12.00	30		3
24	T007-V1235	1/2x12x35	12.7	12.00	35		3
25	T007-V1240	1/2x12x40	12.7	12.00	40		3
26	T007-V1250	1/2x12x50	12.7	12.00	50		3

T008 V-Series, 32 Nano coating, straight Bit price list
 V-Serisi, 32 Nano Kaplama Elmas Freze



Note:
 All products are
 3 nm superhard
 coating

NO	Parça No	Boyut mm	Sap Çapı	Biçak Çapı	Biçak Uzunluk		Uç Sayısı
NO.	Part No.	SIZE mm	Ød SHK	ØD CED	L1		Z
1	T008-V0620	1/2*6 *20	12.7	6	20		3
2	T008-V0622	1/2*6 *22	12.7	6	22		3
3	T008-V0625	1/2*6 *25	12.7	6	25		3
4	T008-V0628	1/2*6 *28	12.7	6	28		3
5	T008-V0630	1/2*6 *30	12.7	6	30		3
6	T008-V0820	1/2*8 *20	12.7	8	20		3
7	T008-V0822	1/2*8 *22	12.7	8	22		3
8	T008-V0825	1/2*8 *25	12.7	8	25		3
9	T008-V0828	1/2*8 *28	12.7	8	28		3
10	T008-V0830	1/2*8 *30	12.7	8	30		3
11	T008-V0832	1/2*8 *32	12.7	8	32		3
12	T008-V0835	1/2*8 *35	12.7	8	35		3
13	T008-V1020	1/2*10 *20	12.7	10	20		3
14	T008-V1023	1/2*10 *23	12.7	10	23		3
15	T008-V1025	1/2*10 *25	12.7	10	25		3
16	T008-V1028	1/2*10 *28	12.7	10	28		3
17	T008-V1030	1/2*10 *30	12.7	10	30		3
18	T008-V1033	1/2*10 *33	12.7	10	33		3
19	T008-V1035	1/2*10 *35	12.7	10	35		3
20	T008-V1040	1/2*10 *40	12.7	10	40		3
21	T008-V1050	1/2*10 *50	12.7	10	50		3
22	T008-V1225	1/2x12x25	12.7	12	25		3
23	T008-V1230	1/2x12x30	12.7	12	30		3
24	T008-V1235	1/2x12x35	12.7	12	35		3
25	T008-V1240	1/2x12x40	12.7	12	40		3
26	T008-V1250	1/2x12x50	12.7	12	50		3

T010

T010 S-series 3Z, Nano coating, composite spiral



Note:
All products are
3 nm superhard
coating

Sap çapı: 12/ 12.7 / 16 mm seçenekli, diş sayısı: 2Z/3Z seçenekli

NO	Parça No	Boyut mm	Sap Çapı	Bıçak Çapı	Bıçak Uzunluk
NO.	Part No.	SIZE mm	Ød SHK	ØD CED	L1
1	T010-S0620	1/2*6 *20	12.7	6	20
2	T010-S0622	1/2*6 *22	12.7	6	22
3	T010-S0820	1/2*8 *20	12.7	8	20
4	T010-S0822	1/2*8 *22	12.7	8	22
5	T010-S0825	1/2*8 *25	12.7	8	25
6	T010-S0828	1/2*8 *28	12.7	8	28
7	T010-S0830	1/2*8 *30	12.7	8	30
8	T010-S1020	1/2*10 *20	12.7	10	20
9	T010-S1023	1/2*10 *23	12.7	10	23
10	T010-S1025	1/2*10 *25	12.7	10	25
11	T010-S1028	1/2*10 *28	12.7	10	28
12	T010-S1030	1/2*10 *30	12.7	10	30
13	T010-S1220	1/2x12x20	12.7	12.00	20
14	T010-S1225	1/2x12x25	12.7	12.00	25
15	T010-S1228	1/2x12x28	12.7	12.00	28
16	T010-S1230	1/2x12x30	12.7	12.00	30
17	T010-S1235	1/2x12x35	12.7	12.00	35

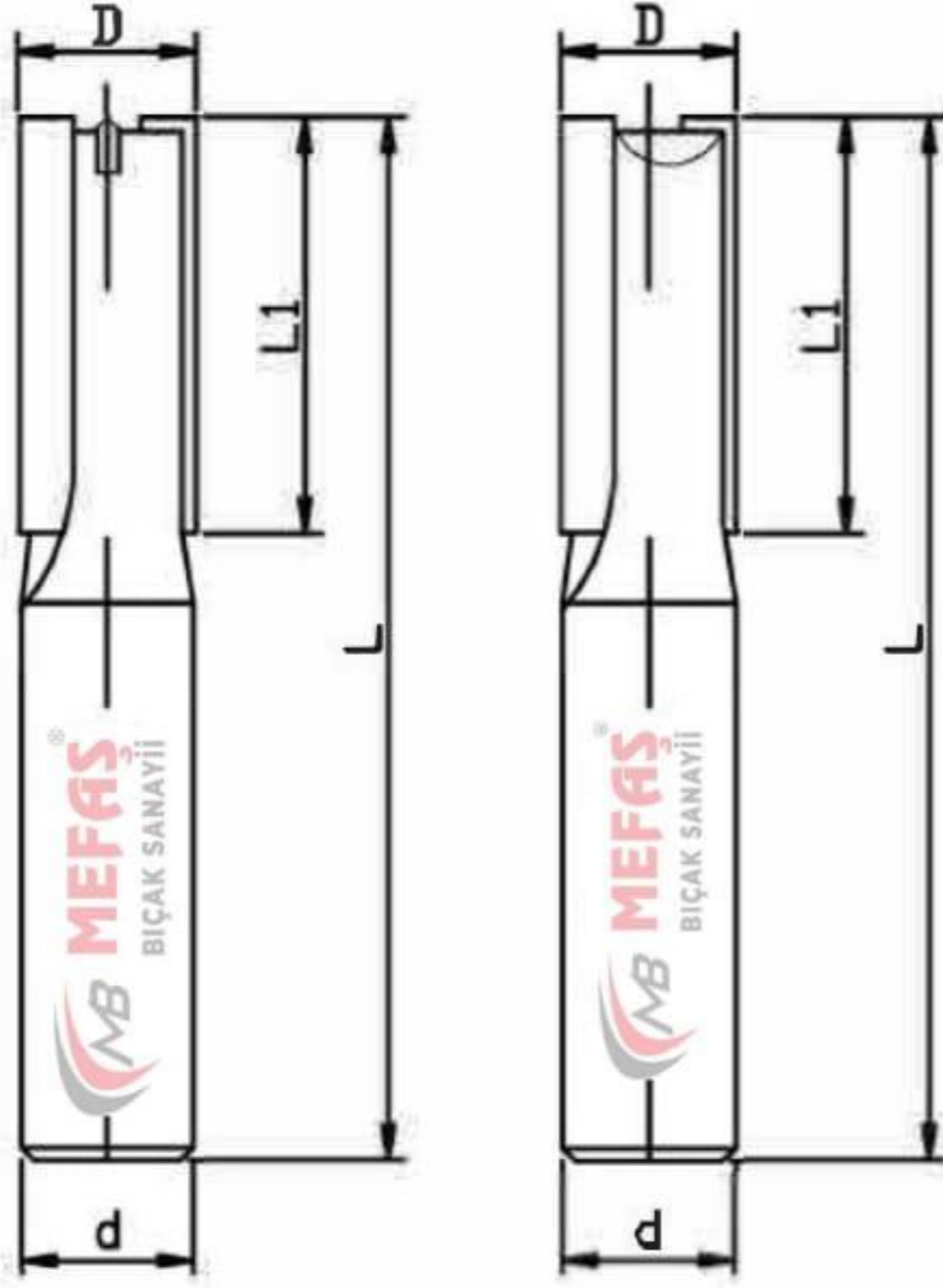

Sap çapı: 6/6.35/8/10/12/12.7/16 mm seçenekli, diş sayısı: 2/3/4Z seçenekli

NO	Parça No	Boyut mm	Sap Çapı	Bıçak Çapı	Bıçak Uzunluk	Diş Sayısı
NO.	Part No.	SIZE mm	Ød SHK	ØD CED	L1	Z
1	ST0014101	d6*D3*H10	6	3	10	1
2	ST0014102	d12.7*D4*H12	12.7	4	12	2
3	ST0014103	d12.7*D5*H12	12.7	5	12	2
4	ST0014104	d12.7*D5*H15	12.7	5	15	2
5	ST0014105	d12.7*D6*H12	12.7	6	12	2
6	ST0014106	d12.7*D6*H15	12.7	6	15	2
7	ST0014107	d12.7*D6*H20	12.7	6	20	2
8	ST0014108	d12.7*D6*H22	12.7	6	22	2
9	ST0014109	d12.7*D8*H15	12.7	8	15	2
10	ST0014110	d12.7*D8*H20	12.7	8	20	2
11	ST0014111	d12.7*D8*H22	12.7	8	22	2
12	ST0014112	d12.7*D8*H25	12.7	8	25	2
13	ST0014113	d12.7*D10*H22	12.7	10	22	2
14	ST0014114	d12.7*D10*H25	12.7	10	25	2
15	ST0014115	d12.7*D10*H30	12.7	10	30	2
16	ST0014116	d12.7*D12*H22	12.7	12	22	2
17	ST0014117	d12*D12*H30	12	12	30	2
18	ST0014118	d12.7*D12.7*H22	12.7	12.7	22	2
19	ST0014119	d12.7*D12.7*H25	12.7	12.7	25	2
20	ST0014120	d12.7*D12.7*H30	12.7	12.7	30	2
21	ST0014121	d12.7*D12.7*H38	12.7	12.7	38	2
22	ST0014122	d12.7*D12.7*H50.8	12.7	12.7	50.8	2
21	ST0014121	d16*D16*H30	16	16	30	2
22	ST0014122	d16*D16*H45	16	16	45	2

Taban Temizleme Bıçağı

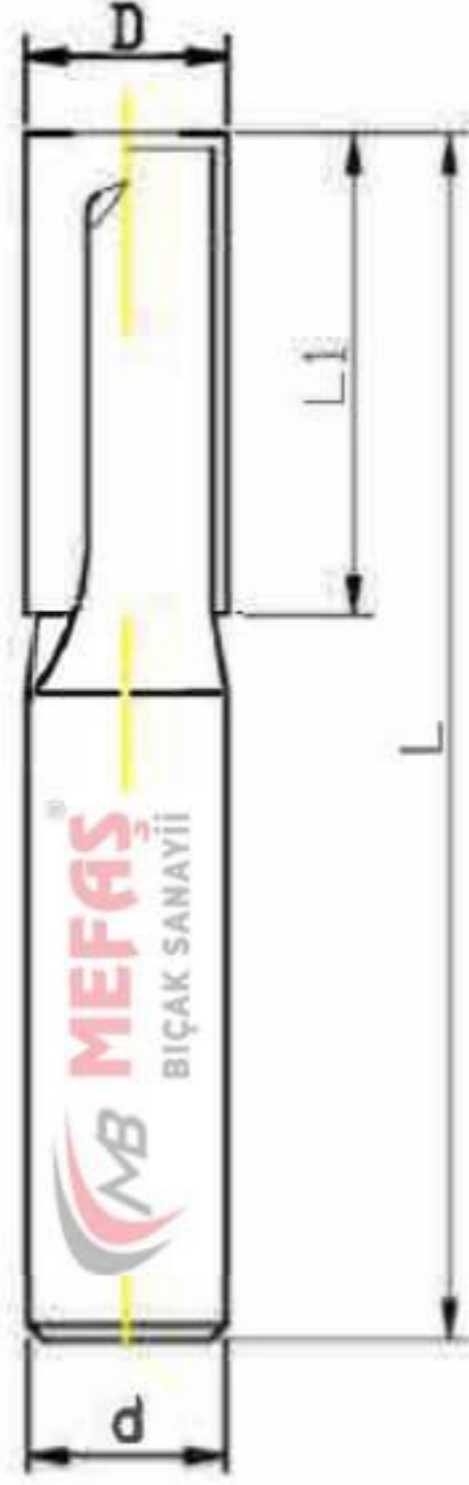

Sap çapı: 6/6. 35/8/10/12/12. 7/16 mm seçenekli, diş sayısı: 2/3/4Z seçenekli

NO	Parça No	Boyut mm	Sap Çapı	Bıçak Çapı	Bıçak Uzunluk	Diş Sayısı
NO.	Part No.	SIZE mm	Ød SHK	ØD CED	L1	Z
1	ST001701	d12.7*D10*H15	12.7	10	15	2
2	ST001711	d12.7*D10*H20	12.7	10	20	2
3	ST001712	d12.7*D10*H25	12.7	10	25	2
4	ST001713	d12.7*D10*H30	12.7	10	30	2
5	ST001714	d12.7*D12*H22	12.7	12	22	2
6	ST001715	d12.7*D12*H30	12.7	12	30	2
7	ST001702	d12.7*D12.7*H10	12.7	12.7	10	2
8	ST001703	d12.7*D12.7*H15	12.7	12.7	15	2
9	ST001704	d12.7*D12.7*H22	12.7	12.7	22	2
10	ST001705	d12.7*D12.7*H20	12.7	12.7	20	2
11	ST001706	d12.7*D12.7*H25.4	12.7	12.7	25.4	2
12	ST001707	d12.7*D12.7*H30	12.7	12.7	30	2
13	ST001716	d12.7*D15*H20	12.7	15	20	2
14	ST001708	d16*D16*H30	16	16	30	2
15	ST001709	d16*D16*H35	16	16	35	2
16	ST001710	d16*D16*H40	16	16	40	2

Taban Temizleme Ucu

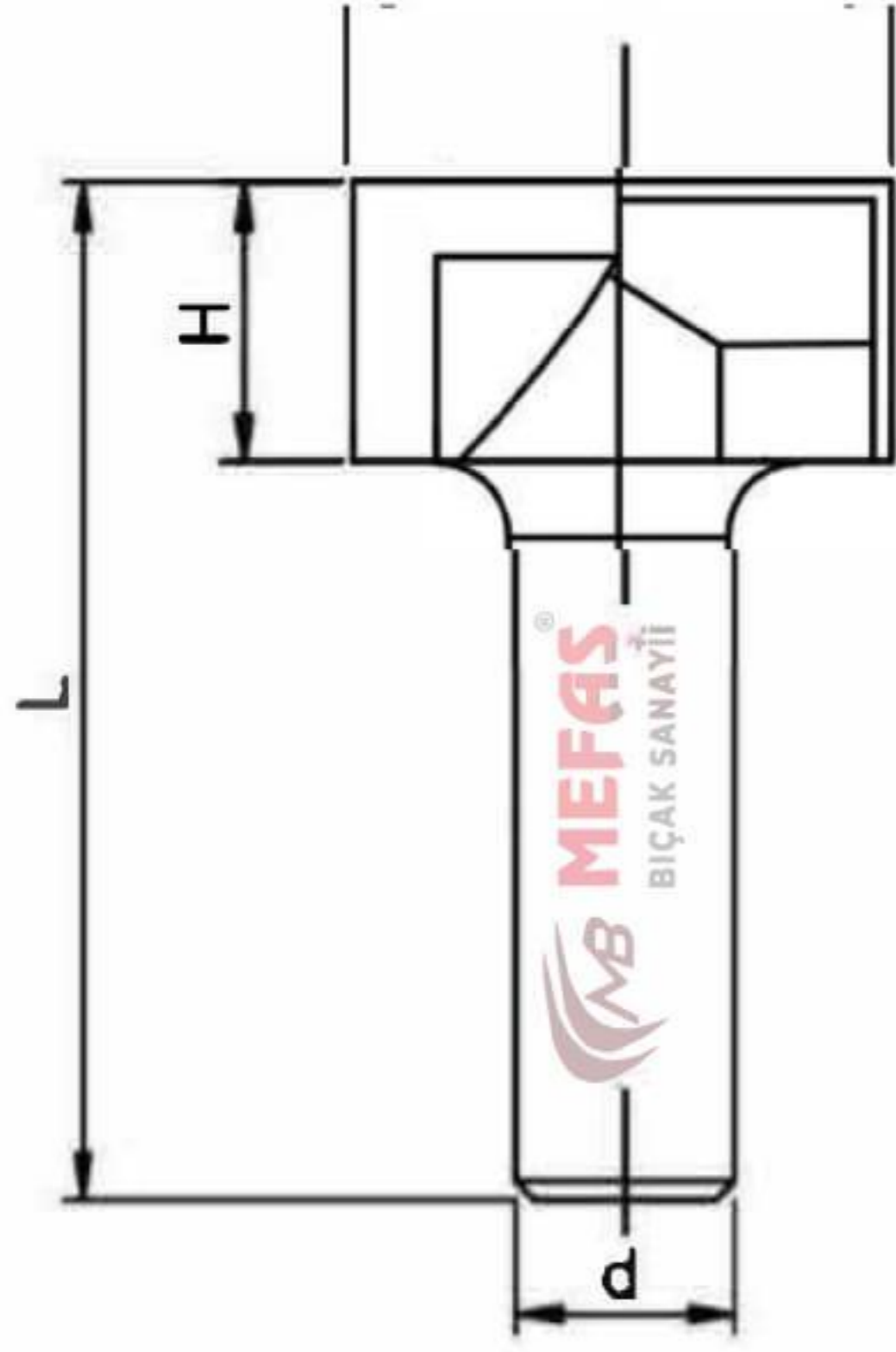

Sap çapı: 6/6. 35/8/10/12/12. 7 /16 mm seçenekli, diş sayısı: 2/3/4Z seçenekli

NO	Parça No	Boyut mm	Sap Çapı	Bıçak Çapı	Bıçak Uzunluğu
NO.	Part No.	SIZE mm	Ød SHK	ØD CED	H
1	ST0018116	d12.7*D4*H12	12.7	4	12
2	ST0018117	d12.7*D6*H12	12.7	6	12
3	ST0018118	d12.7*D8*H15	12.7	8	15
4	ST0018101	d12.7*D9*H15	12.7	9	15
5	ST0018102	d12.7*D10*H15	12.7	10	15
6	ST0018103	d12.7*D12*H15	12.7	12	15
7	ST0018119	d12.7*D12.7*H15	12.7	12.7	15
8	ST0018104	d12.7*D15*H15	12.7	15	15
9	ST0018105	d12.7*D20*H15	12.7	20	15
10	ST0018106	d12.7*D22*H15	12.7	22	15
11	ST0018107	d12.7*D25*H15	12.7	25	15
12	ST0018108	d12.7*D30*H15	12.7	30	15
13	ST0018109	d12.7*D32*H15	12.7	32	15
14	ST0018110	d12.7*D35*H15	12.7	35	15
15	ST0018111	d12.7*D38*H15	12.7	38	15
16	ST0018112	d12.7*D40*H15	12.7	40	15
17	ST0018113	d12.7*D45*H15	12.7	45	15
18	ST0018114	d12.7*D50*H15	12.7	50	15
19	ST0018115	d12.7*D55*H15	12.7	55	15

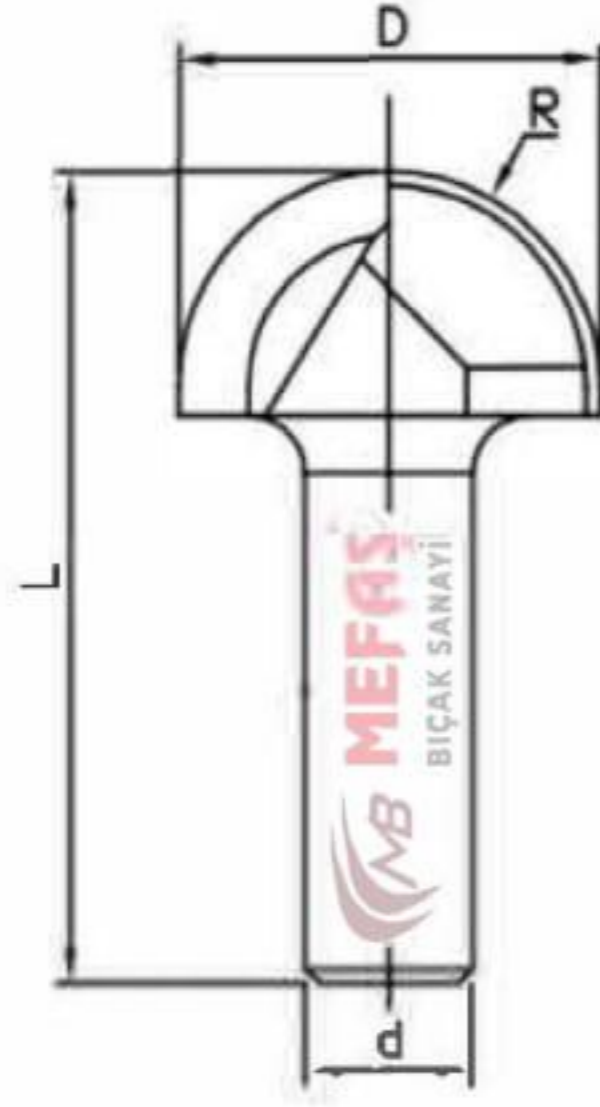

Sap çapı: 6/6. 35/8/10/12/12. 7/16 mm seçenekli

NO	Parça No	Boyut mm	Sap Çapı	Biçak Çapı	Biçak Uzunluğu	Yarıçap	Diş Sayısı
NO.	Part No.	SIZE mm	Ød SHK	ØD CED	H	R	Z
1	ST001614	d12.7*D3*R1.5	12.7	3	2.5	1.5	2
2	ST001615	d12.7*D4*R2	12.7	4	6	2	2
3	ST001601	d12.7*D5*R2.5	12.7	5	5	2.5	2
4	ST001609	d12.7*D6*R3	12.7	6	6	3	2
5	ST001610	d12.7*D6.35*R3.175	12.7	6.35	6	3.175	2
6	ST001602	d12.7*D8*R4	12.7	8	6	4	2
7	ST001611	d12.7*D9.52*R4.76	12.7	9.52	8	4.76	2
8	ST001603	d12.7*D10*R5	12.7	10	7	5	2
9	ST001616	d12.7*D12*R6	12.7	12	8	6	2
10	ST001604	d12.7*D12.7*R6.35	12.7	12.7	8	6.35	2
11	ST001620	d12.7*D15.9*R7.95	12.7	15.9	10	7.95	2
12	ST001605	d12.7*D16*R8	12.7	16	8	8	2
13	ST001612	d12.7*D19.05*R9.525	12.7	19.05	11	9.525	2
14	ST001613	d12.7*D22.2*R11.1	12.7	22.2	13	11.1	2
15	ST001606	d12.7*D25.4*R12.7	12.7	25.4	15	12.7	2
16	ST001617	d12.7*D28.6*R14.3	12.7	28.6	16	14.3	2
17	ST001607	d12.7*D30*R15	12.7	30	17	15	2
18	ST001618	d12.7*D32*R16	12.7	32	18	16	2
19	ST001619	d12.7*D34.9*R17.45	12.7	34.9	19	17.45	2
20	ST001621	d12.7*D38.1*R19.05	12.7	38.1	22	19.05	2
21	ST001608	d12.7*D40*R20	12.7	40	22	20	2
22	ST001622	d12.7*D44.45*R22.225	12.7	44.45	25	22.225	2
23	ST001623	d12.7*D50.8*R25.4	12.7	50.8	28	25.4	2

Yuvarlak Köşe Freze Ucu

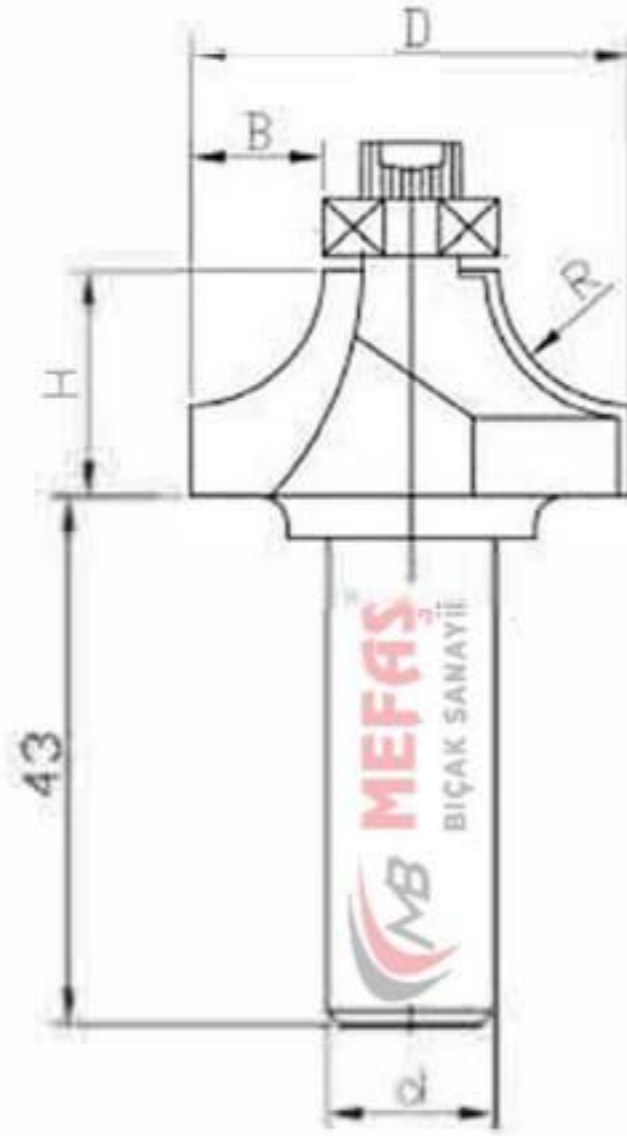

Sap çapı: 6/6. :35/8/10/12/12. 7/16 mm seçenekli. diş sayısı: 2/3/42 seçenekli

NO	Parça No	Boyut mm	Sap Çapı	Biçak Çapı	Biçak Uzunluğu	Yarıçap	Diş Sayısı
NO.	Part No.	SIZE mm	Ød SHK	ØD CED	H	R	Z
1	ST002001	1/2xR2	12.7	13.76	7	2	2
2	ST002002	1/2x3/16	12.7	13.76	7	2.38	2
3	ST002003	1/2x1/4	12.7	15.35	8	3.17	2
4	ST002004	1/2x5/16	12.7	20.94	9	3.97	2
5	ST002005	1/2x3/8	12.7	22.52	9	4.76	2
6	ST002006	1/2xR5	12.7	23	10	5	2
7	ST002007	1/2X1/2	12.7	25.7	11	6.35	2
8	ST002008	1/2X5/8	12.7	28.92	12	7.96	2
9	ST002009	1/2X3/4	12.7	32.04	13.5	9.52	2
10	ST002010	1/2X7/8	12.7	35.2	16	11.1	2
11	ST002011	1/2X1	12.7	38.4	18	12.7	2
12	ST002012	1/2X1-1/8	12.7	41.58	20	14.29	2
13	ST002013	1/2X1-1/4	12.7	44.8	20	15.9	2
14	ST002014	1/2X1-3/8	12.7	47.92	22	17.46	2
15	ST002015	1/2X1-1/2	12.7	51.1	24	19.05	2
16	ST002016	1/2X1-5/8	12.7	54.28	25	20.64	2
17	ST002017	1/2X1-3/4	12.7	57.46	27	22.23	2
18	ST002018	1/2X1-7/8	12.7	60.62	28	23.81	2
19	ST002019	1/2X2	12.7	63.8	30	25.4	2
20	ST002020	1/2X2-1/8	12.7	66.96	31	26.98	2
21	ST002021	1/2X2-1/4	12.7	70.16	33	28.58	2
22	ST002022	1/2X2-3/8	12.7	73.32	35	30.16	2
23	ST002023	1/2X2-1/2	12.7	76.5	36	31.75	2
24	ST002024	1/2X2-5/8	12.7	79.66	38	33.33	2
25	ST002025	1/2X2-3/4	12.7	82.86	39	34.93	2
26	ST002026	1/2X2-7/8	12.7	86.02	41	36.51	2
27	ST002027	1/2X3	12.7	89.2	43	38.1	2

Eğimli Kenar Bıçağı



Sap çapı: 6/6.35/8/10/12/12.7/16 mm seçenekli, diş sayısı: 2/3/4Z seçenekli

NO	Parça No	Boyut mm	Sap Çapı	Bıçak Çapı	Bıçak Genişliği	Eğim Açısı	Diş Sayısı
NO.	Part No.	SIZE mm	Ød SHK	ØD CED	B	a°	Z
1	ST002501	1/2x1/4	12.7	21.98	6.35	45°	2
2	ST002502	1/2x5/16	12.7	24.25	7.96	45°	2
3	ST002503	1/2x3/8	12.7	26.5	9.52	45°	2
4	ST002504	1/2X1/2	12.7	30.96	12.7	45°	2
5	ST002505	1/2X5/8	12.7	35.5	15.9	45°	2
6	ST002506	1/2X3/4	12.7	40	19.05	45°	2
7	ST002507	1/2X7/8	12.7	44.4	22.2	45°	2
8	ST002508	1/2X1	12.7	48.9	25.4	45°	2
9	ST002509	1/2X1-1/8	12.7	53.4	28.6	45°	2
10	ST002510	1/2X1-1/4	12.7	57.9	31.75	45°	2
11	ST002511	1/2X1-3/8	12.7	62.4	34.9	45°	2
12	ST002512	1/2X1-1/2	12.7	67	38.1	45°	2
13	ST002513	1/2X1-5/8	12.7	71.37	41.27	45°	2
14	ST002514	1/2X1-3/4	12.7	75.86	44.45	45°	2

Kenar Düzeltme Bıçağı

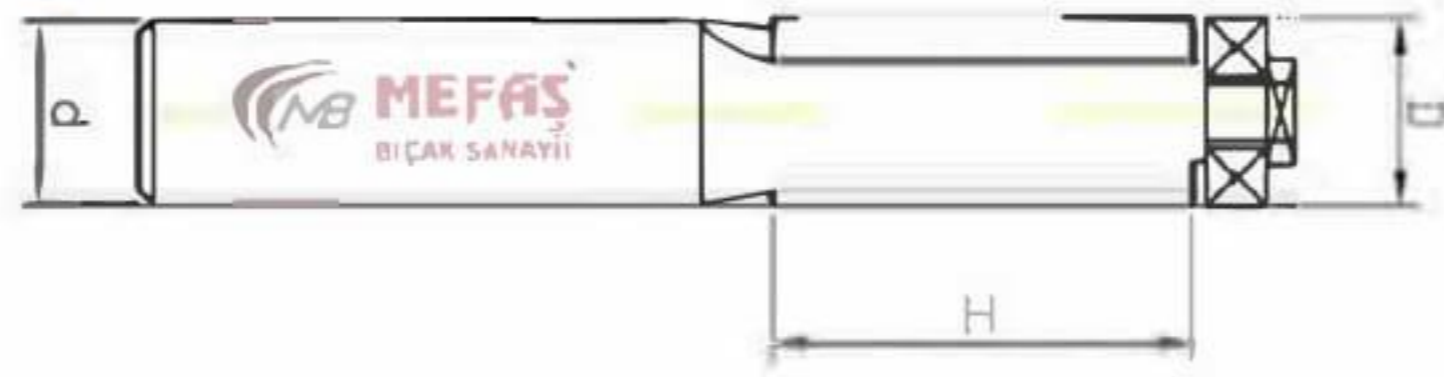

Sap çapı: 6/6.35/8/10/12/12.7/16 mm seçenekli, diş sayısı: 2/3/4Z seçenekli

NO	Parça No	Boyut mm	Sap Çapı	Bıçak Çapı	Bıçak Uzunluğu	Diş Sayısı
NO.	Part No.	SIZE mm	Ød SHK	ØD CED	H	Z
1	ST002601	1/4x1/4	6.35	6	20	2
2	ST002602	1/4x5/16	6.35	8	25	2
3	ST002603	1/4x3/8	6.35	9	30	2
4	ST002604	1/4X1/2	6.35	13	30	2
5	ST002605	1/2X1/4	12.7	6	20	2
6	ST002606	1/2X5/16	12.7	8	25	2
7	ST002607	1/2X3/8	12.7	9	30	2
8	ST002608	1/2X1/2 H25	12.7	13	25	2
9	ST002609	1/2X1/2 H30	12.7	13	30	2

V Tipi Bıçak

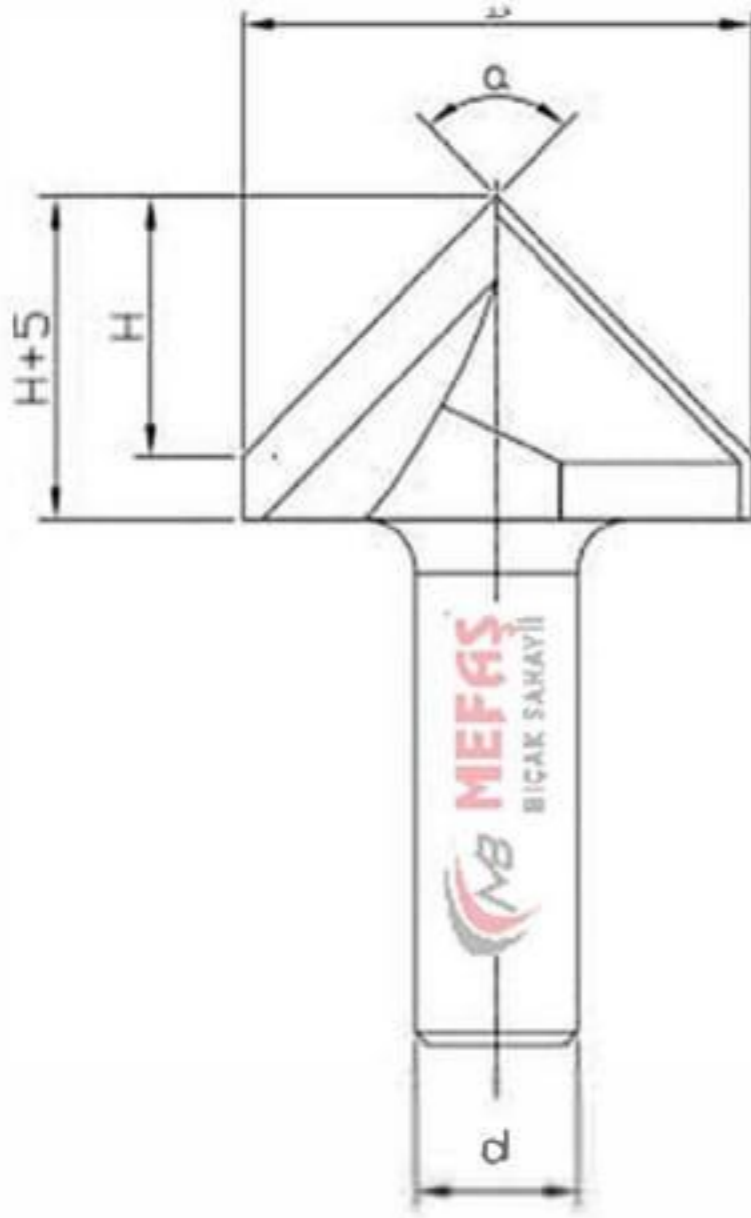

.. Sap Ç81Jl: 6/6-8/10/12/12 7/16/20 111111 seçeneğ kl. 1 tl • is savısı: 2/°) / 42 seçenekli

NO	Parça No	Boyut mm	Sap Çapı	Bıçak Çapı	Bıçak Uzunluğu	Eğim Açısı	Diş Sayısı
NO.	Part No.	SIZE mm	Ød SHK	ØD CED	H	a°	Z
1	ST002701	d12.7*D14*H12*V60	12.7	14	12	60	1
2	ST002702	d12.7*D12.7*H6.35*V90	12.7	12.7	6.35	90	2
3	ST002703	d12.7*D15.9*H7.95*V90	12.7	15.9	7.95	90	2
4	ST002704	d12.7*D22*H11*V90	12.7	22	11	90	2
5	ST002705	d12.7*D25.4*H12.7*V90	12.7	25.4	12.7	90	2
6	ST002706	d12.7*D30*H15*V90	12.7	30	15	90	2
7	ST002707	d12.7*D32*H16*V90	12.7	32	16	90	2
8	ST002708	d12.7*D35*H17.5*V90	12.7	35	17.5	90	2
9	ST002709	d12.7*D40*H20*V90	12.7	40	20	90	2
10	ST002710	d12.7*D44.5*H22.2*V90	12.7	44.5	22.2	90	2
11	ST002711	d12.7*D50*H25*V90	12.7	50	25	90	2
12	ST002712	d12.7*D30*H11.51*V105	12.7	30	11.51	105	2
13	ST002713	d12.7*D40*H15.35*V105	12.7	40	15.35	105	2
14	ST002714	d12.7*D52*H19.52*V105	12.7	52	19.52	105	2
15	ST002715	d12.7*D25.4*H7.33*V120	12.7	25.4	7.33	120	2
16	ST002716	d12.7*D30*H8.66*V120	12.7	30	8.66	120	2
17	ST002717	d12.7*D32*H9.24*V120	12.7	32	9.24	120	2
18	ST002718	d12.7*D35*H10.1*V120	12.7	35	10.1	120	2
19	ST002719	d12.7*D40*H11.55*V120	12.7	40	11.55	120	2
20	ST002720	d12.7*D42*H12.12*V120	12.7	42	12.12	120	2
21	ST002721	d12.7*D45*H12.99*V120	12.7	45	12.99	120	2
22	ST002722	d12.7*D50*H14.43*V120	12.7	50	14.43	120	2
23	ST002723	d12.7*D45*H11.63*V125	12.7	45	11.63	125	2
24	ST002724	d12.7*D45*H10.6*V130	12.7	45	10.6	130	2
25	ST002725	d12.7*D42*H7.06*V142	12.7	42	7.06	142	2
26	ST002726	d12.7*D22*H2.95*V150	12.7	22	2.95	150	2
27	ST002727	d12.7*D32*H4.29*V150	12.7	32	4.29	150	2
28	ST002728	d12.7*D42*H5.63*V150	12.7	42	5.63	150	2
29	ST002729	d12.7*D50*H6.7*V150	12.7	50	6.7	150	2
30	ST002730	d12.7*D63*H8.44*V150	12.7	63	8.44	150	2
31	ST002731	d12.7*D46*H5.95*V151	12.7	46	5.95	151	2
32	ST002732	d12.7*D60*H7.2*V153	12.7	60	7.2	153	2

CARVING CUTTER

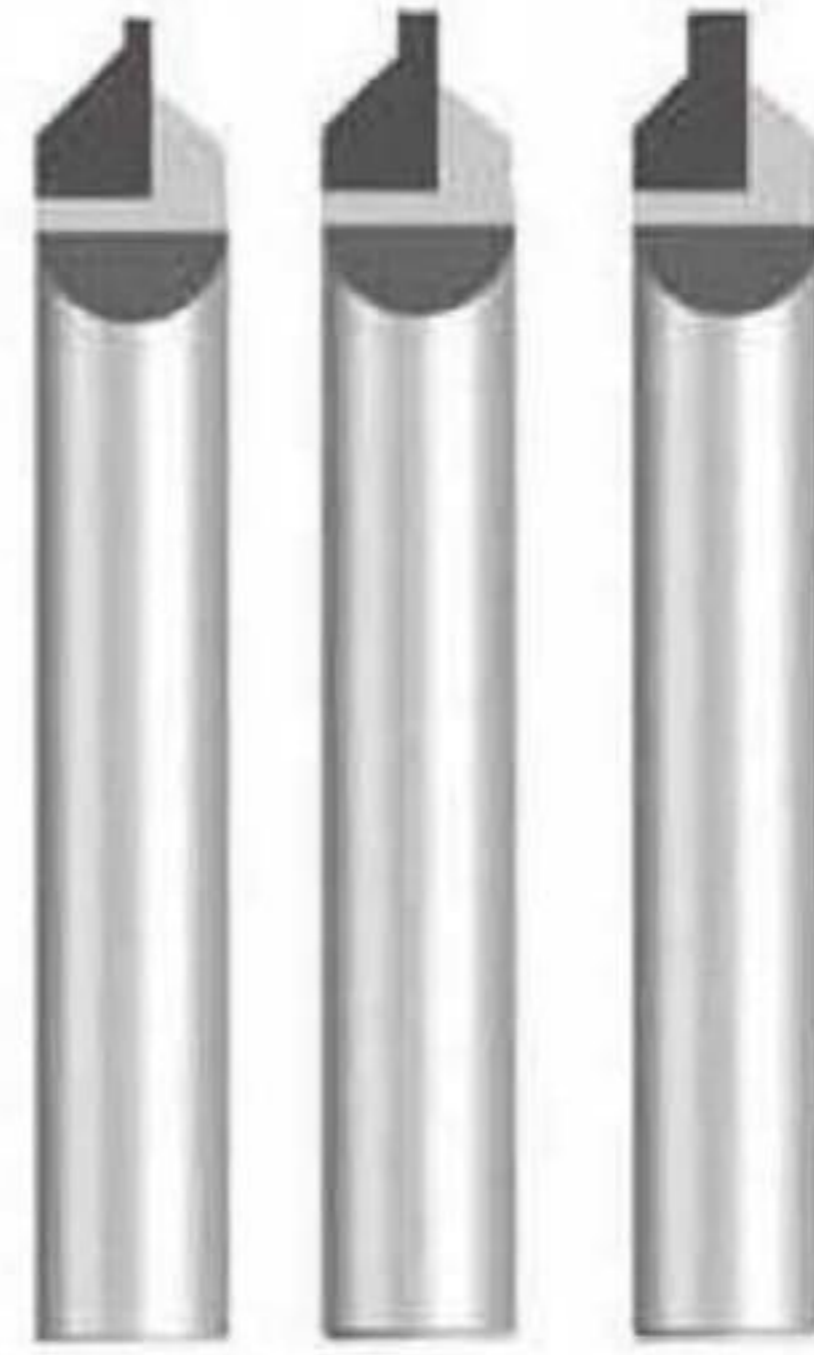
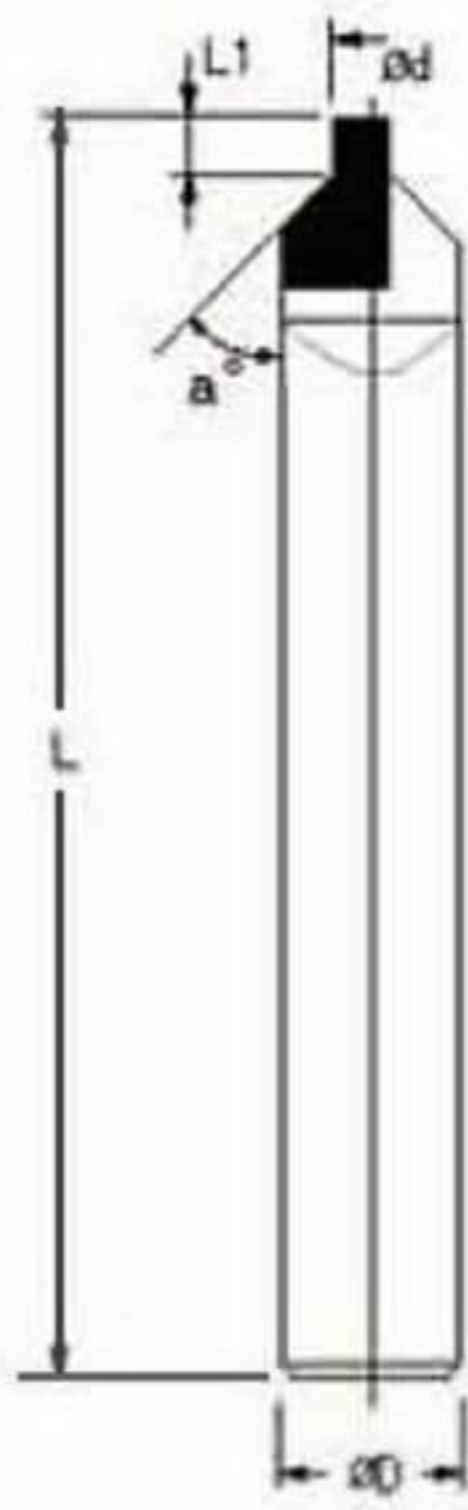

Part NO.	ØD	L	Ød	L1	a°
ST002301	6	50	0.75	1	45°
ST002302	6	50	1.25	1	45°
ST002303	6	50	1.25	1.5	45°
ST002304	6	50	1.5	0.8	45°
ST002305	6	50	1.5	1	45°
ST002306	6	50	1.5	1.2	45°
ST002307	6	50	1.5	1.6	22°
ST002308	6	50	1.5	2.1	27°



Dia (PCD) Saplı Freze Bıçağı

PCD Woodworking Edge Banding Jointing
Rabbeting Cutter Diamond chip-free Jointing Cutter
Diamond chip-free Jointing Cutter



***Diamond
Profile Router***

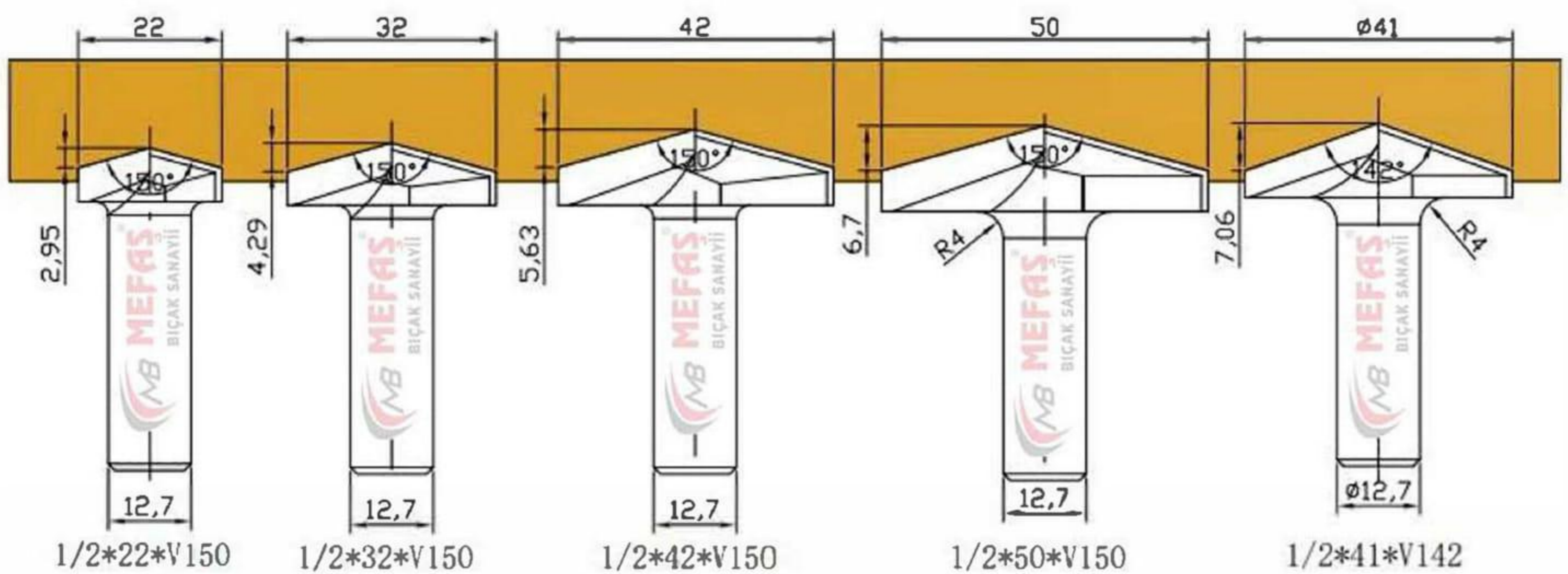
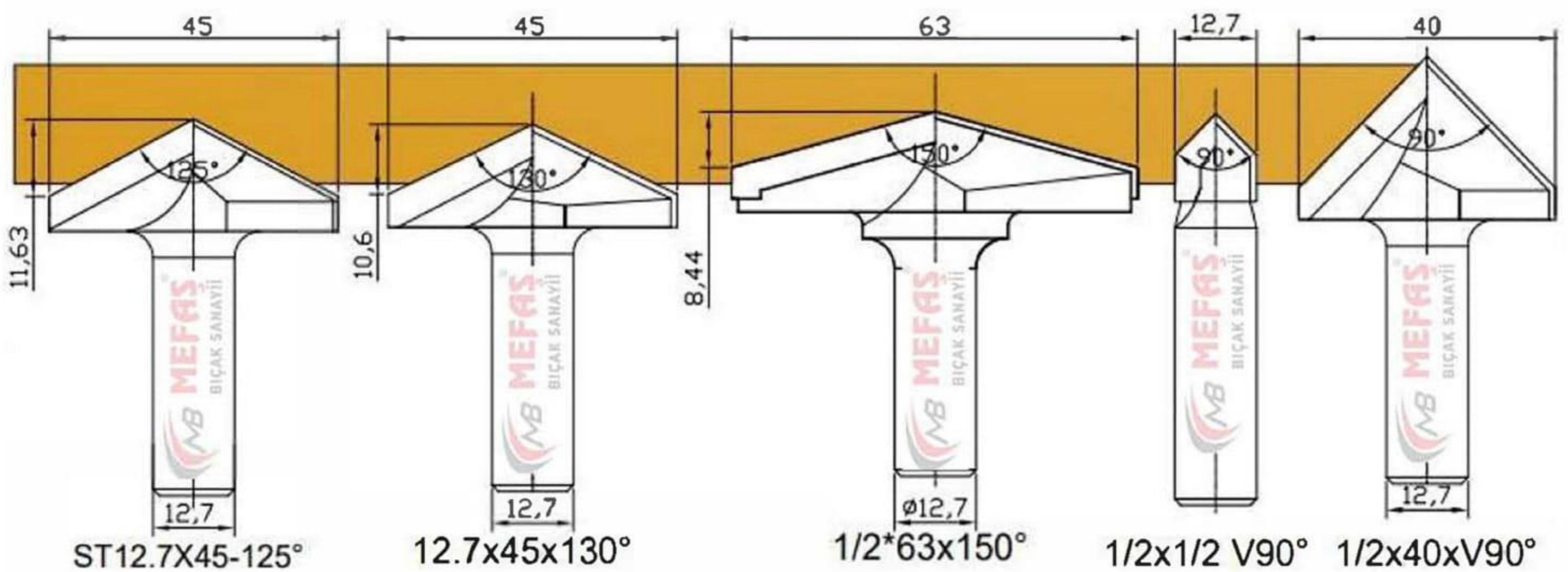
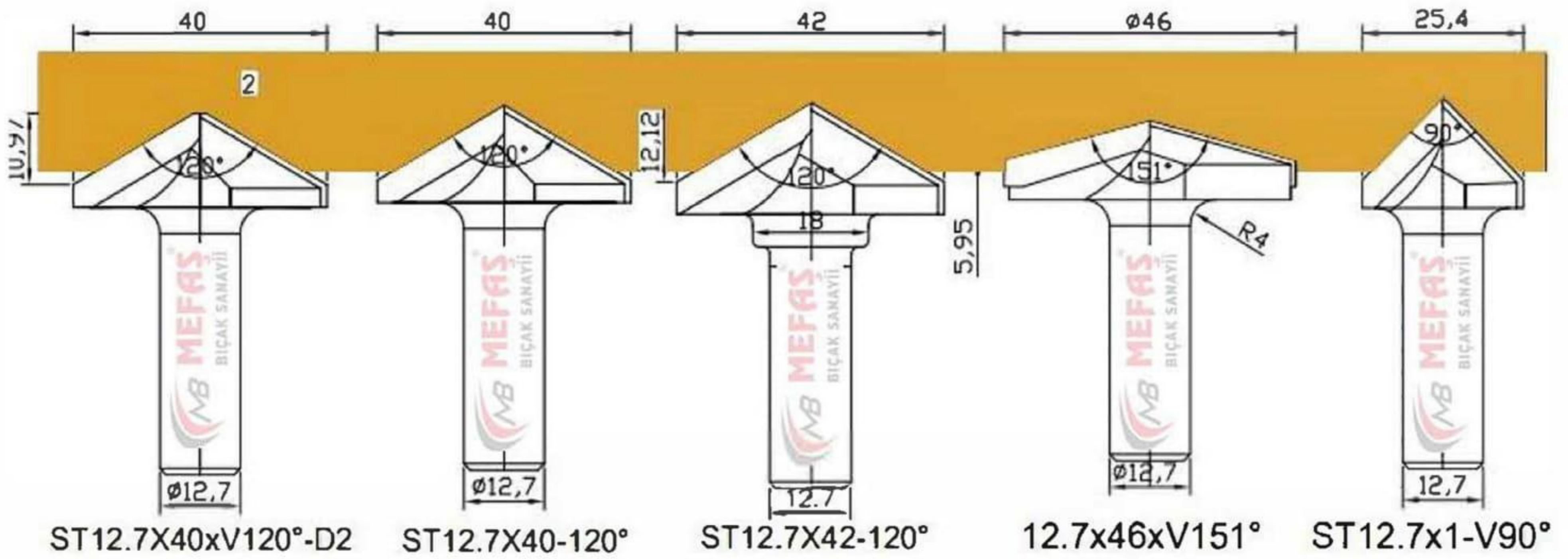

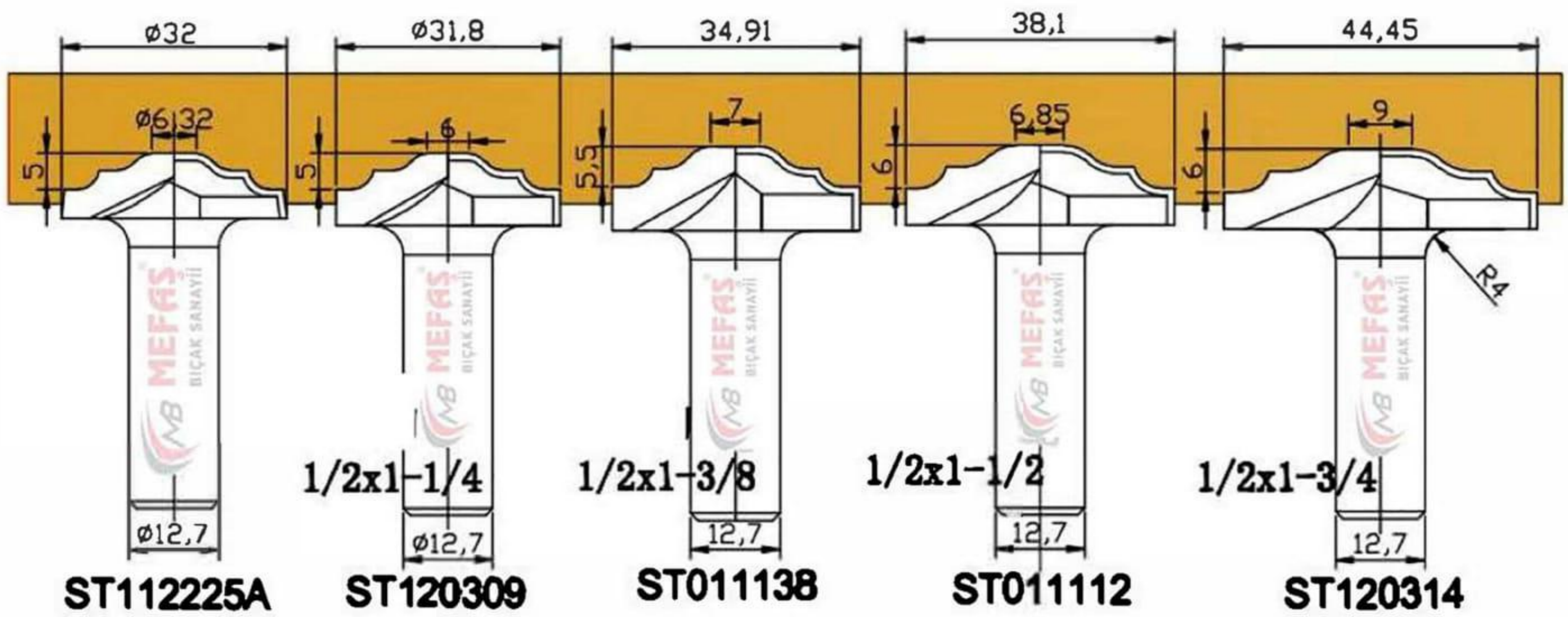
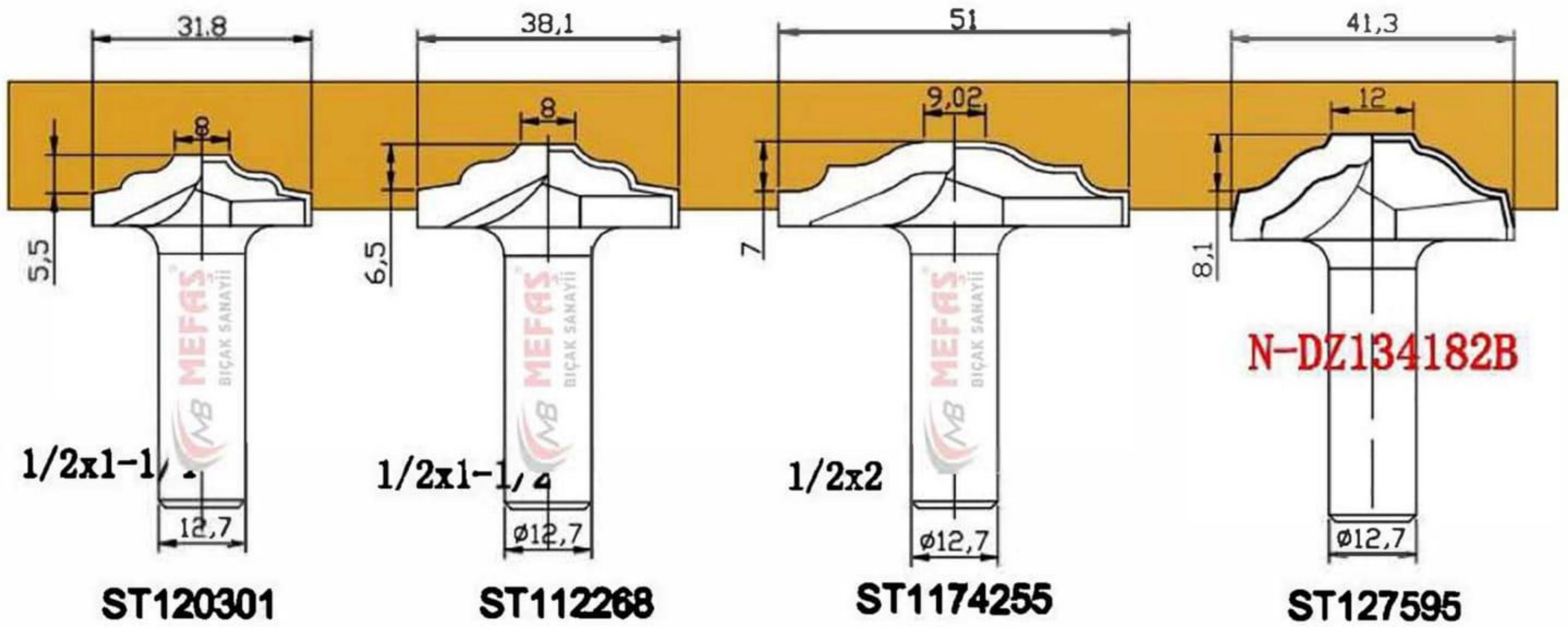
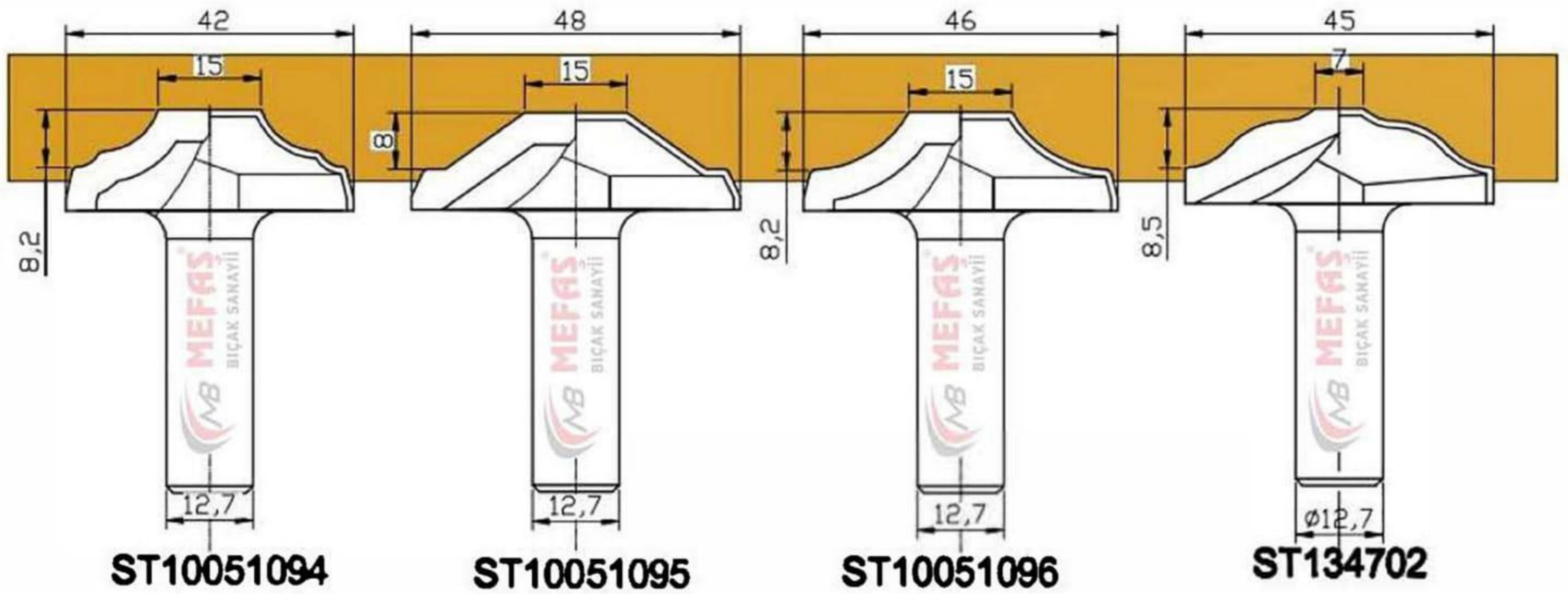

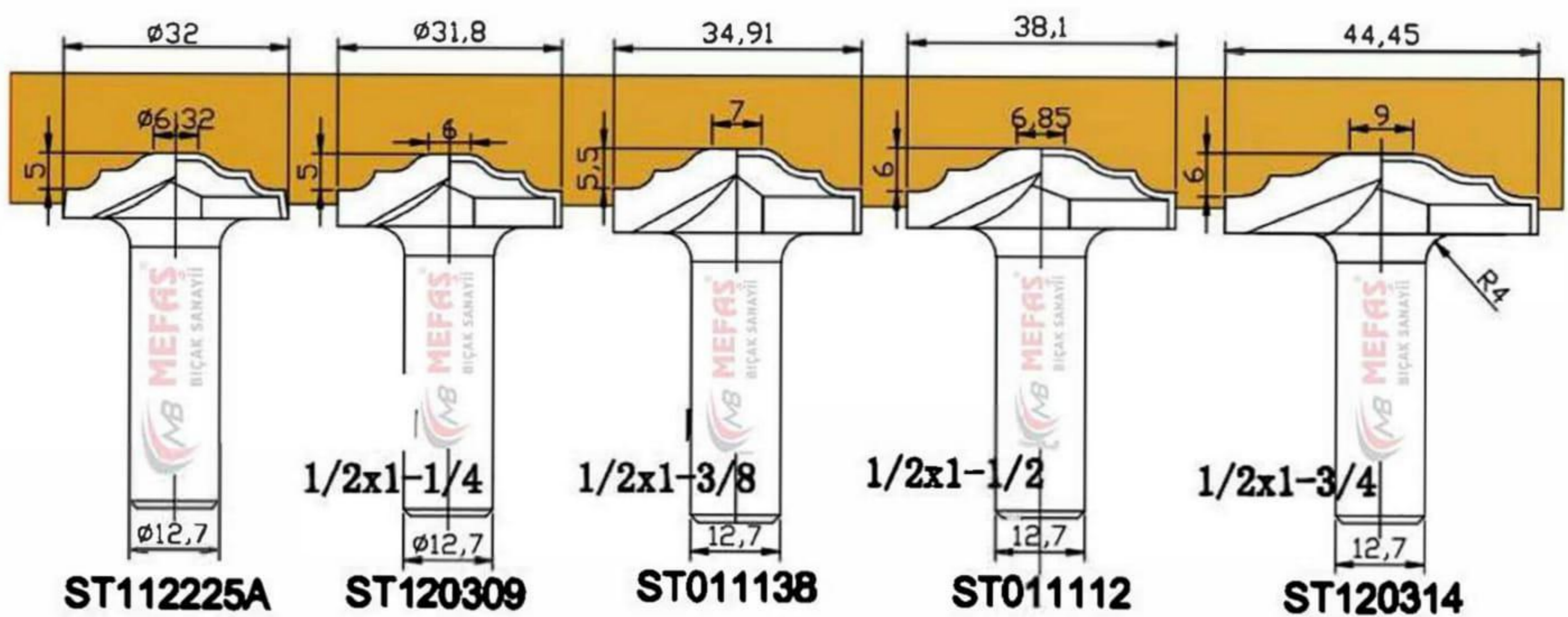
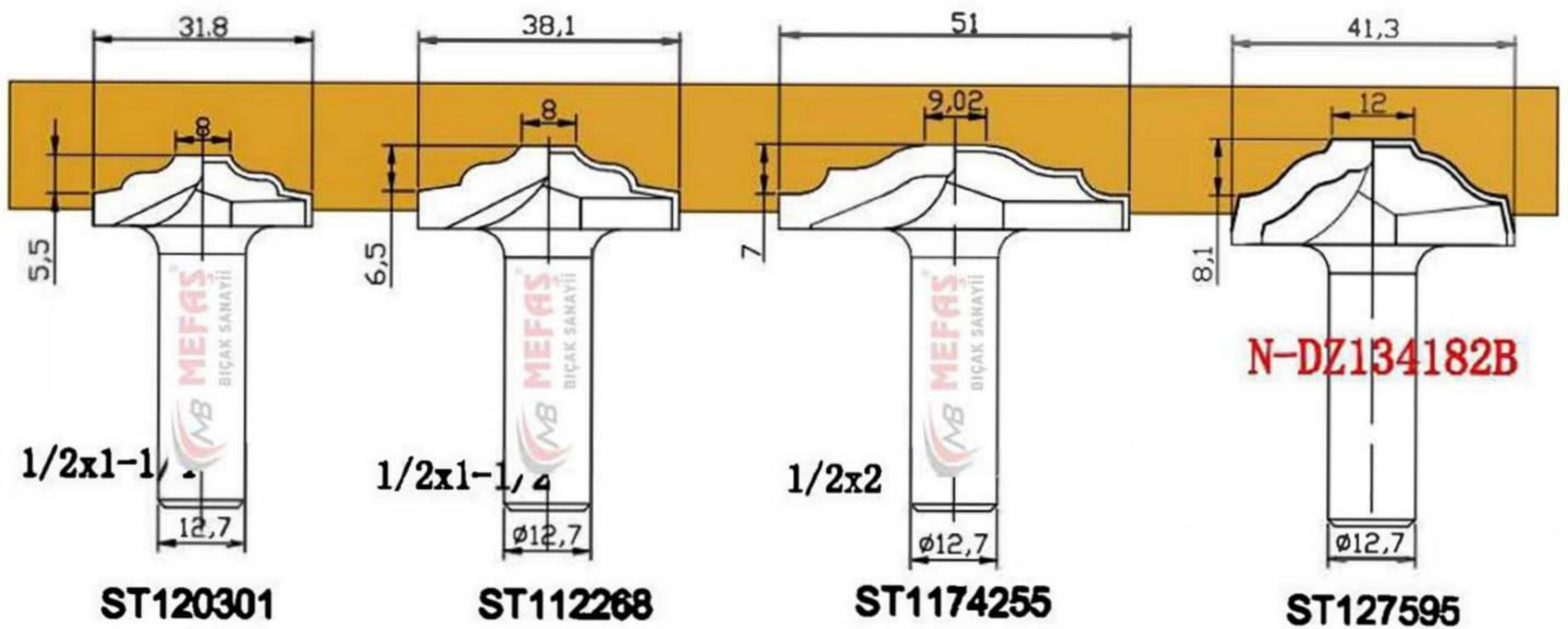
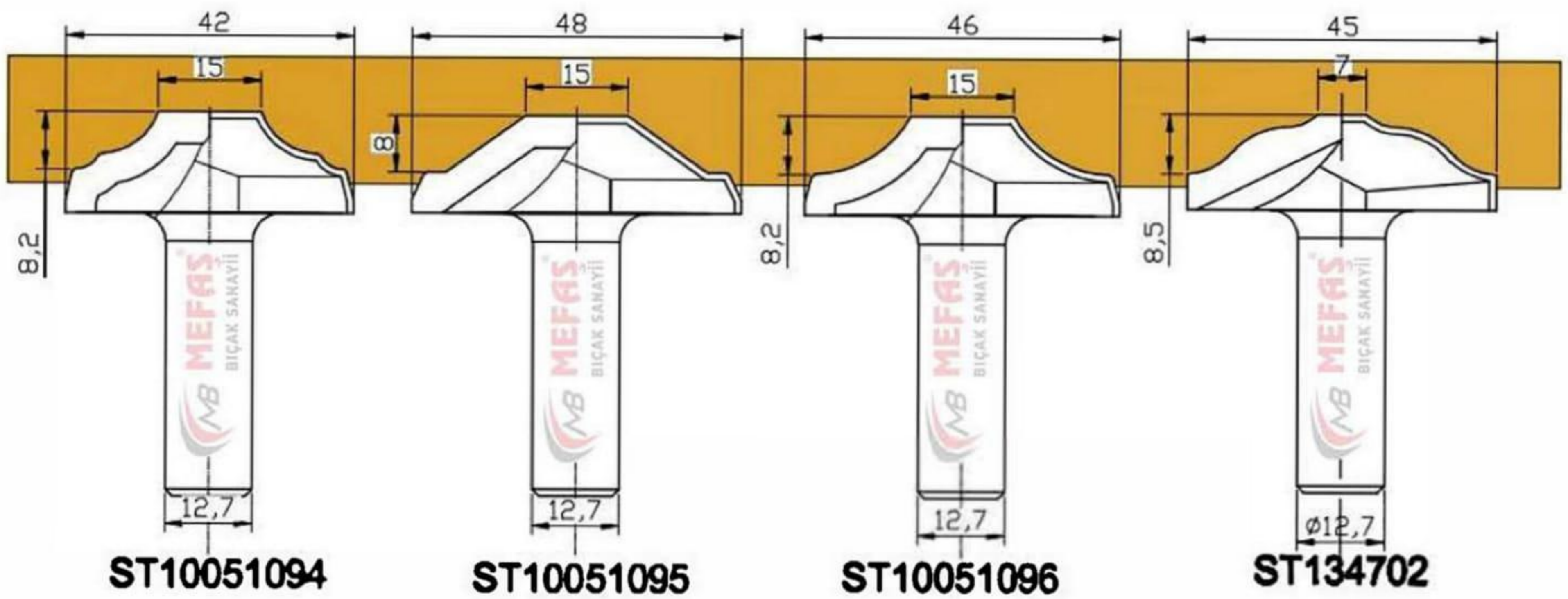

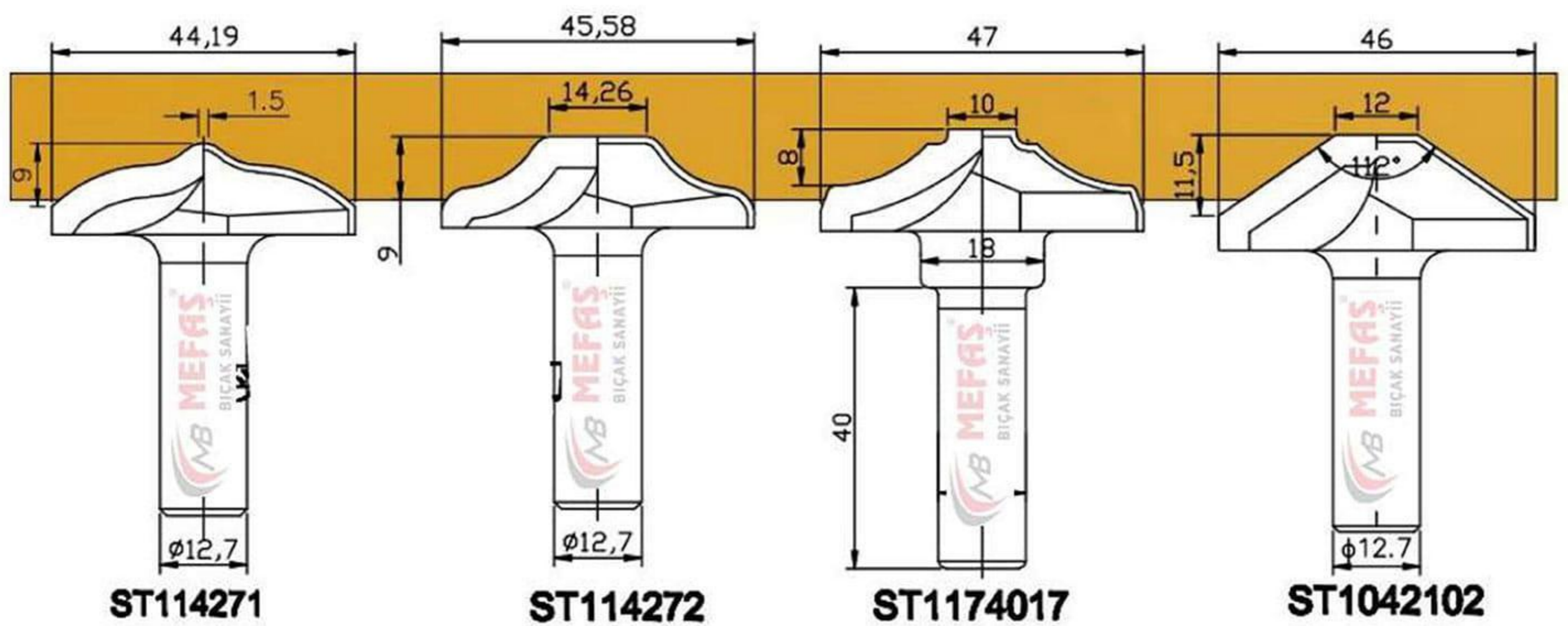
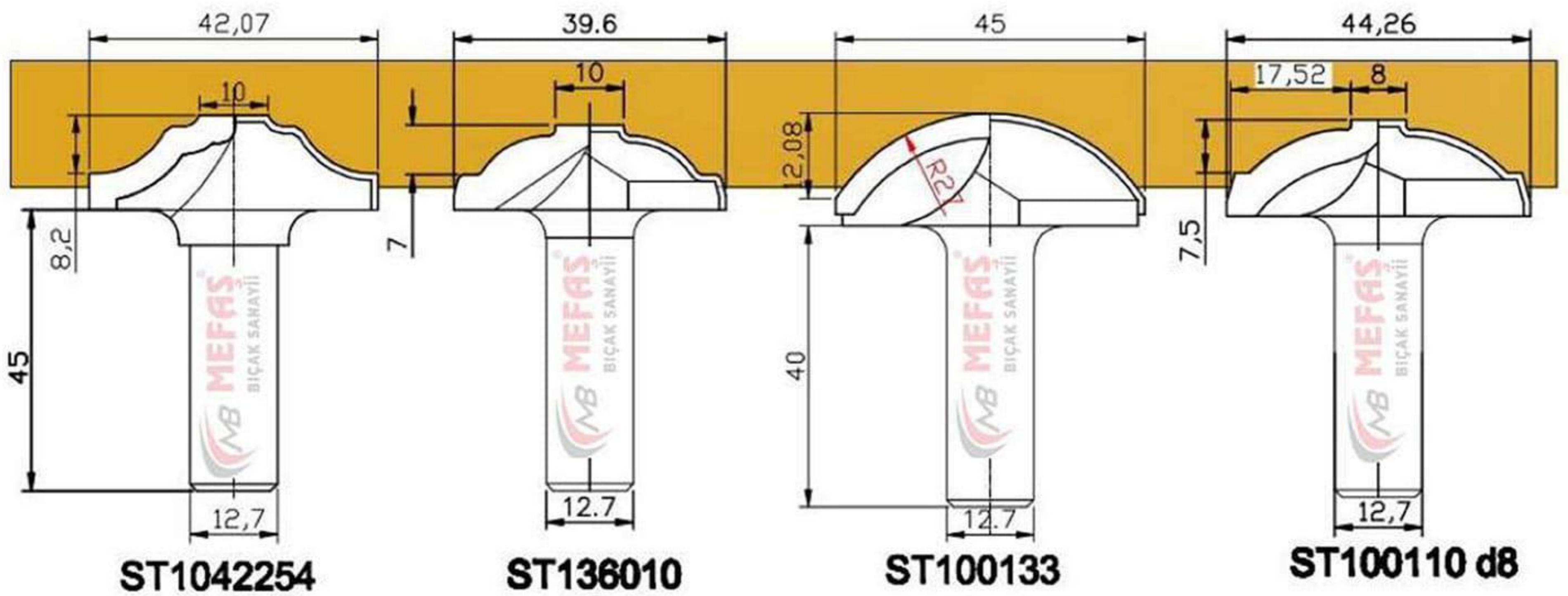
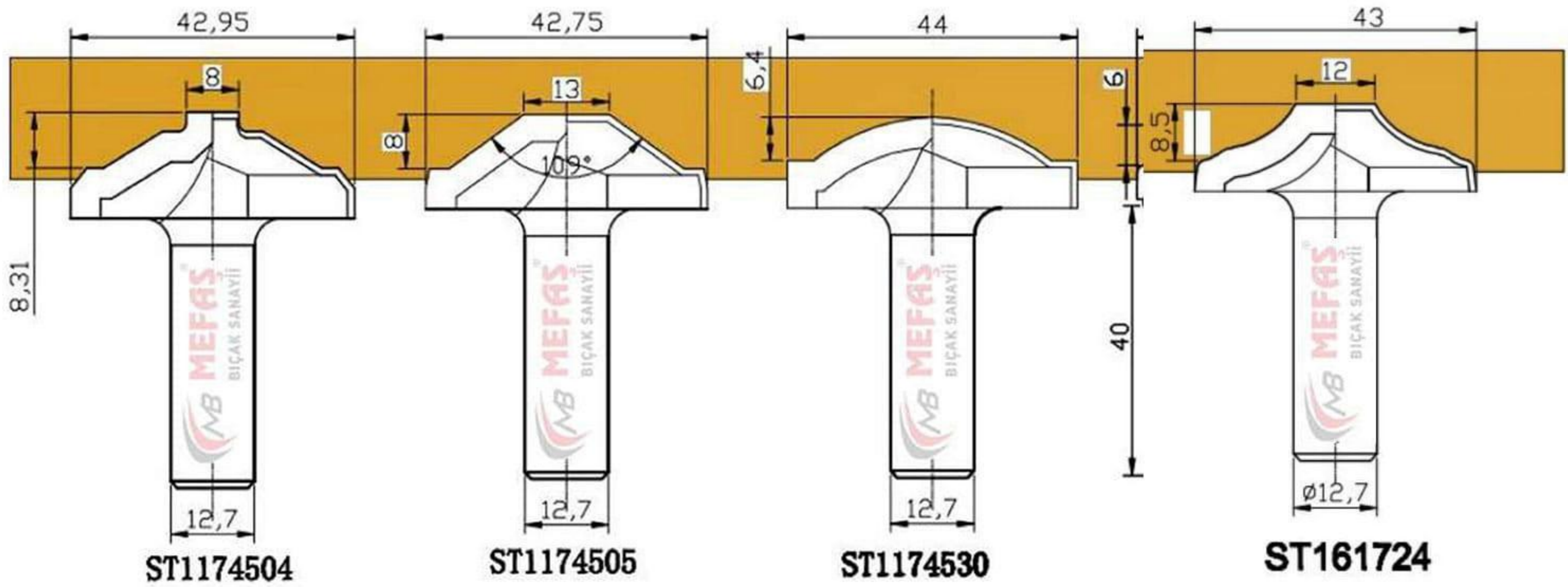

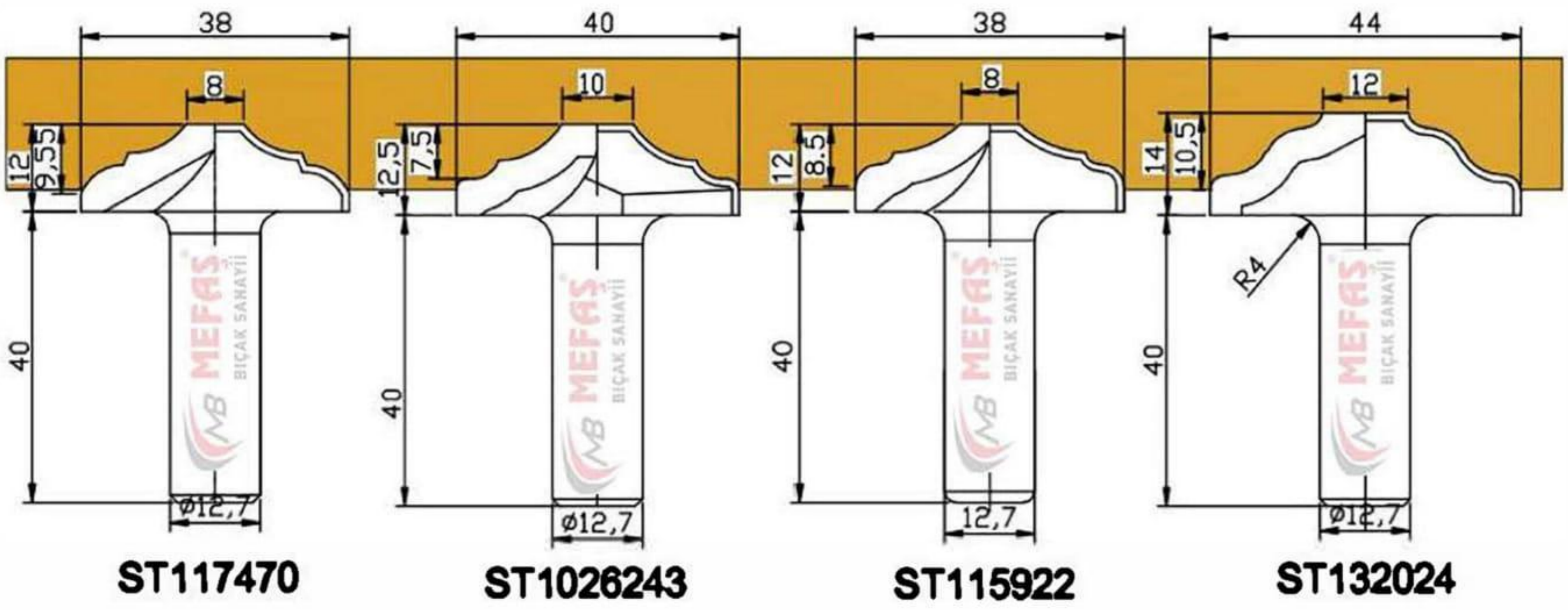
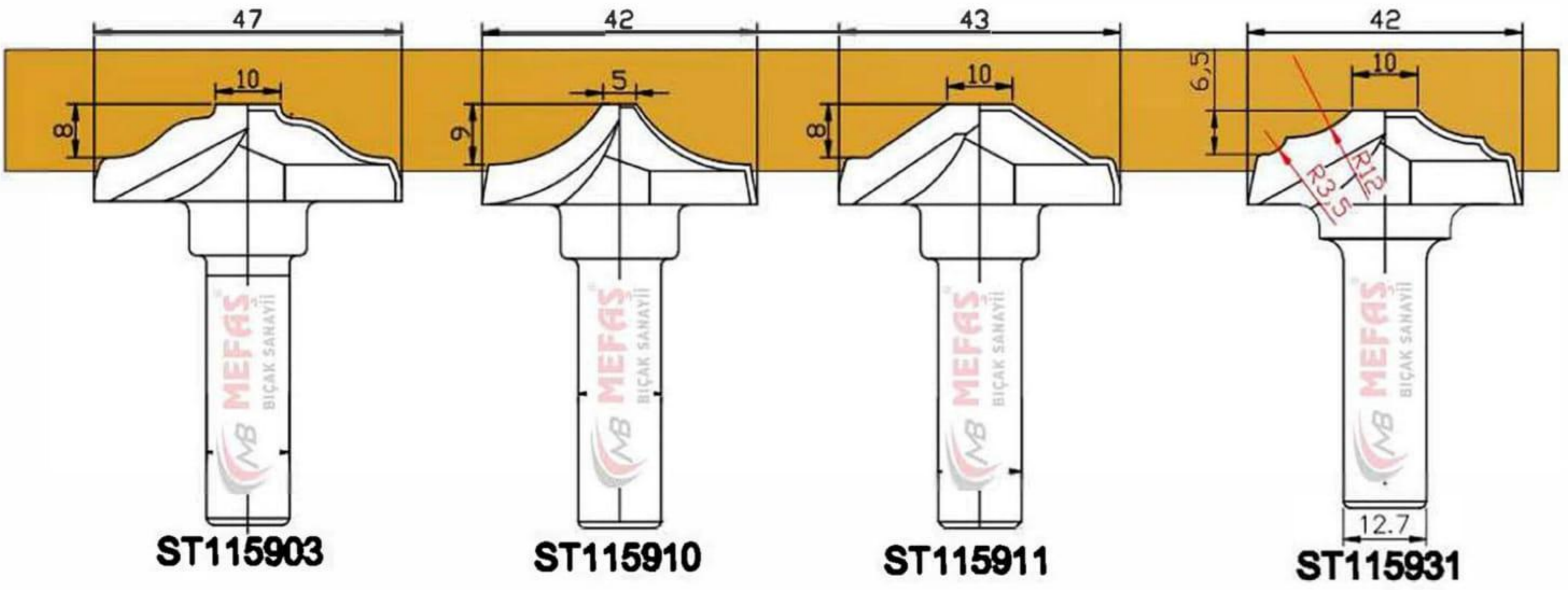
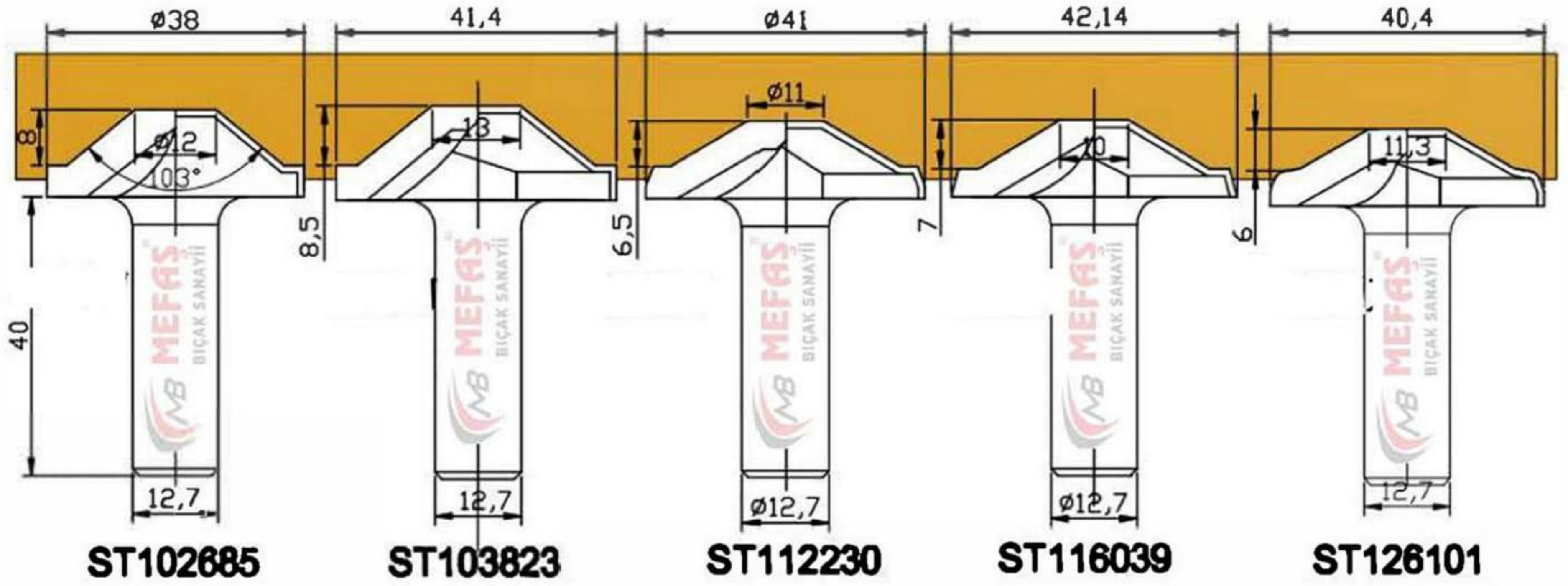

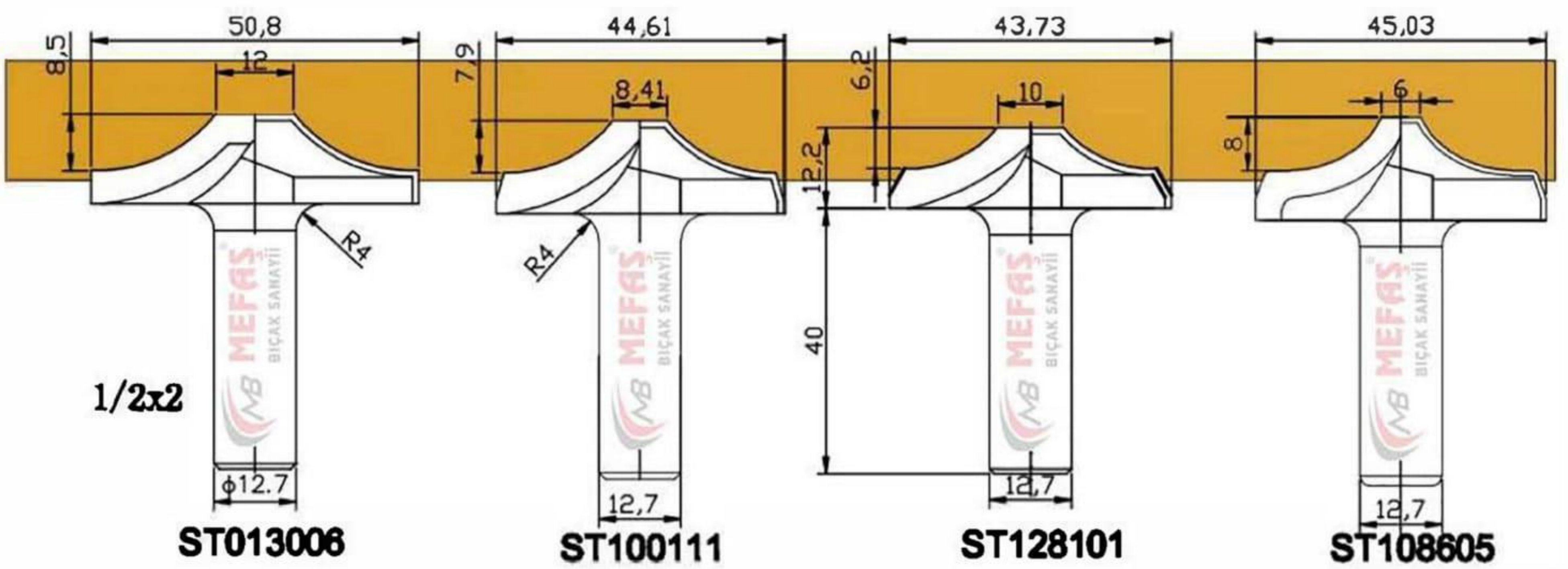
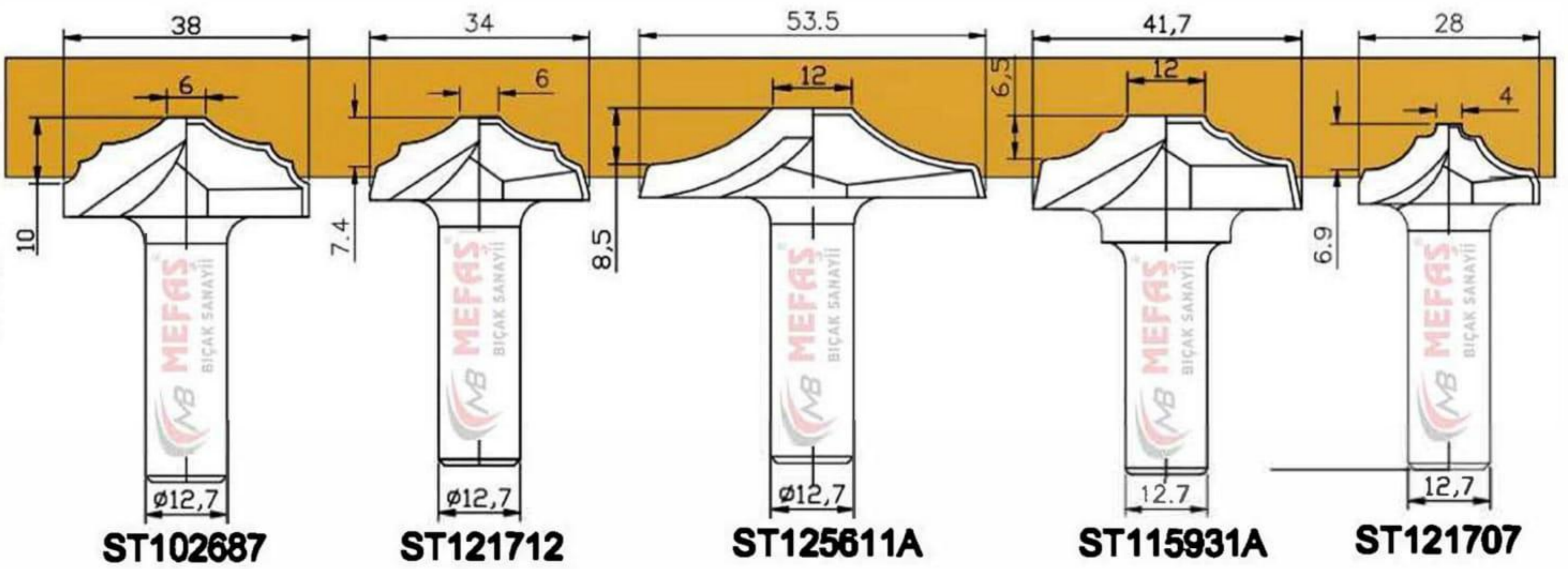
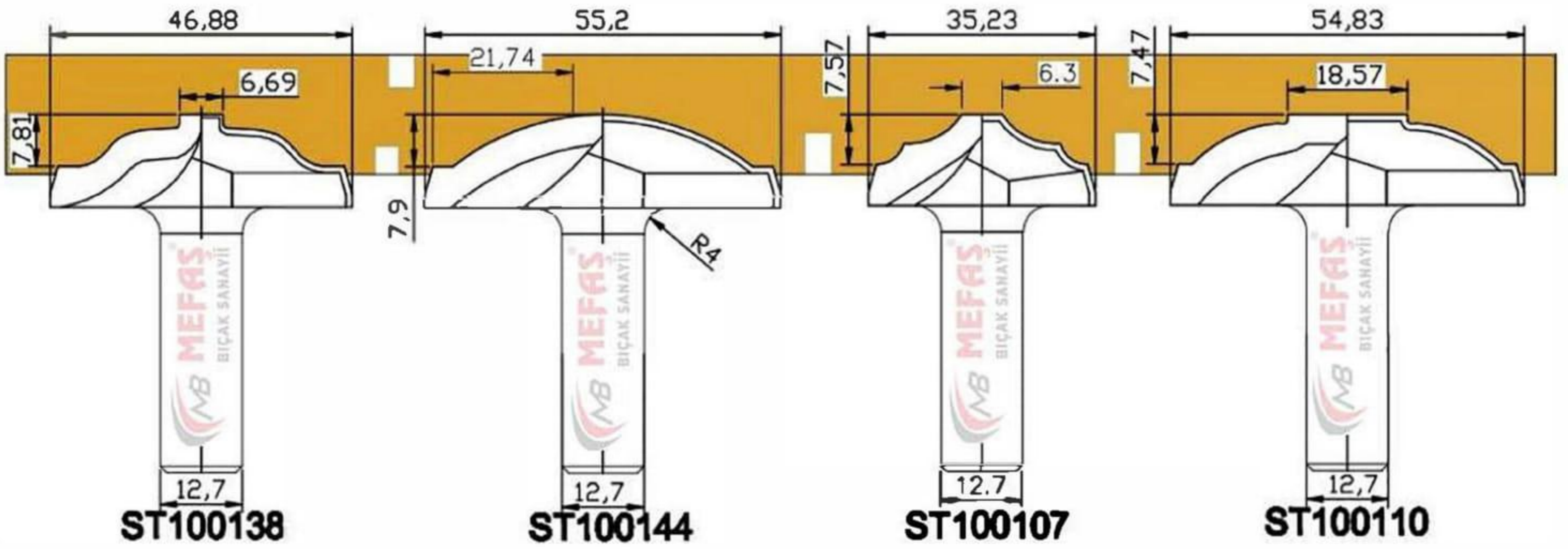

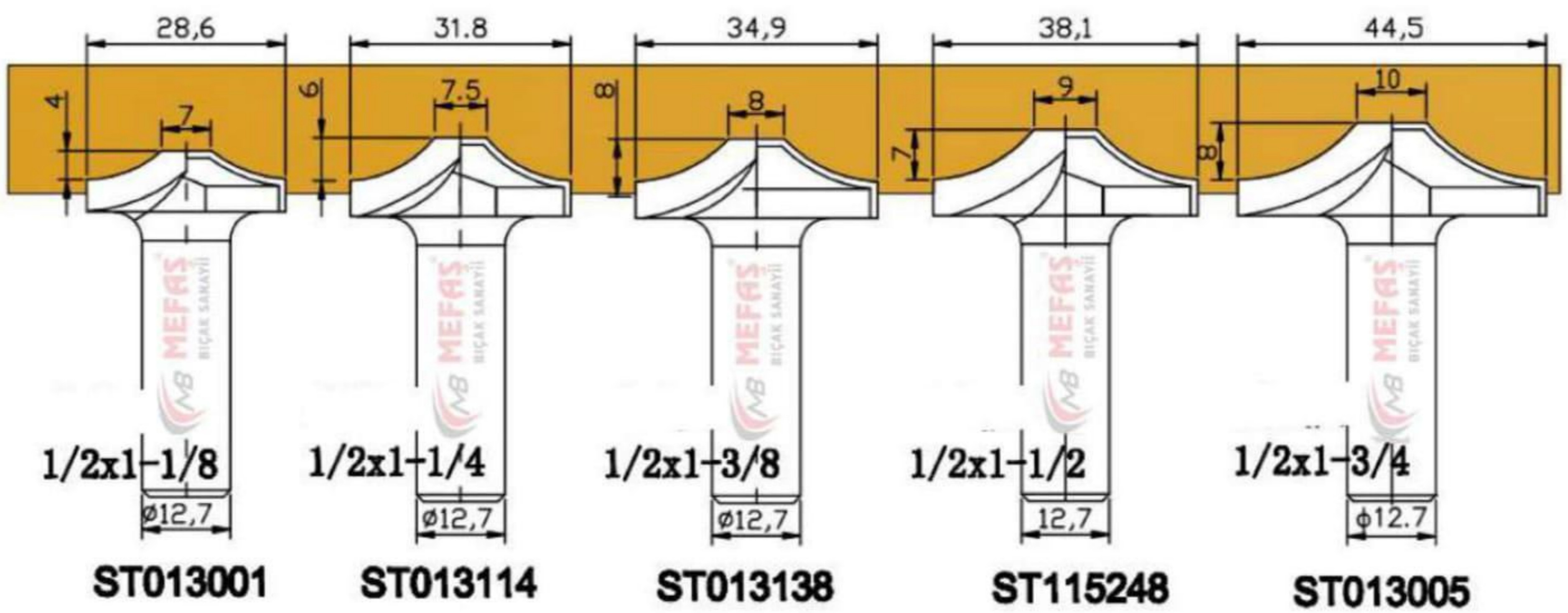
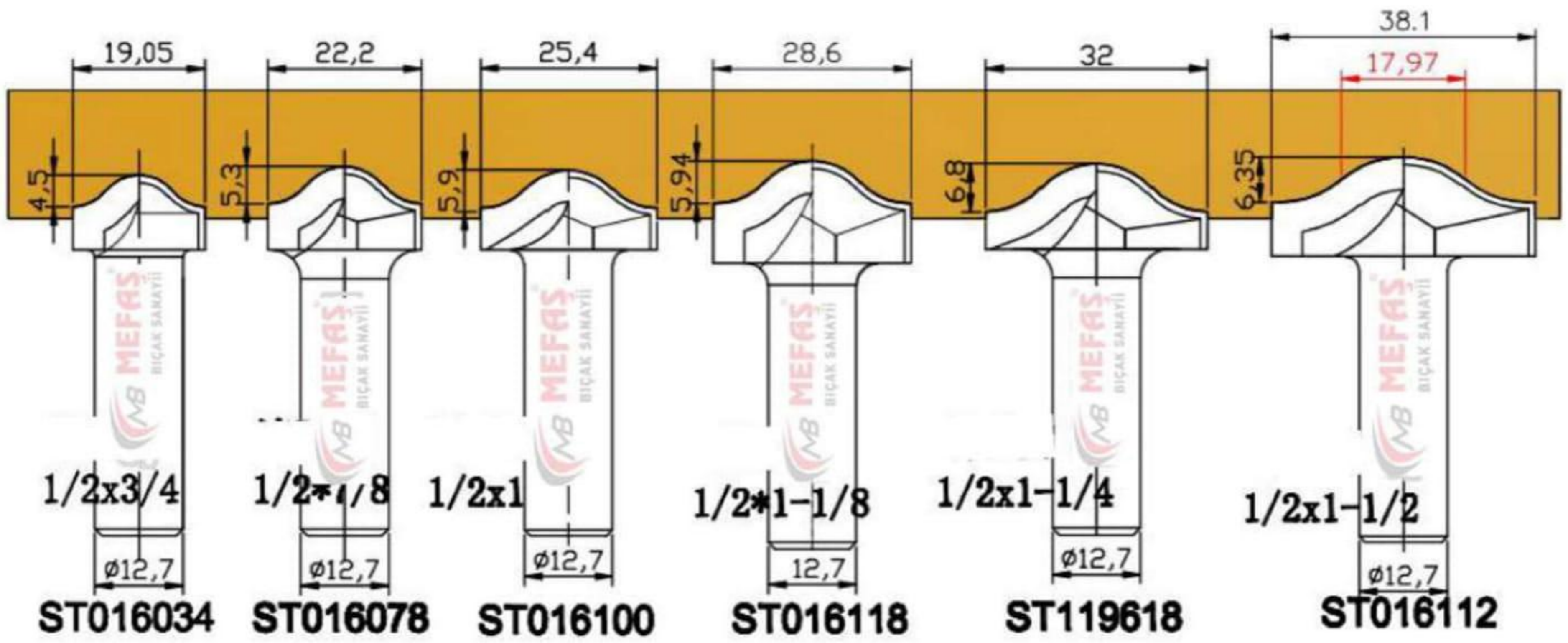
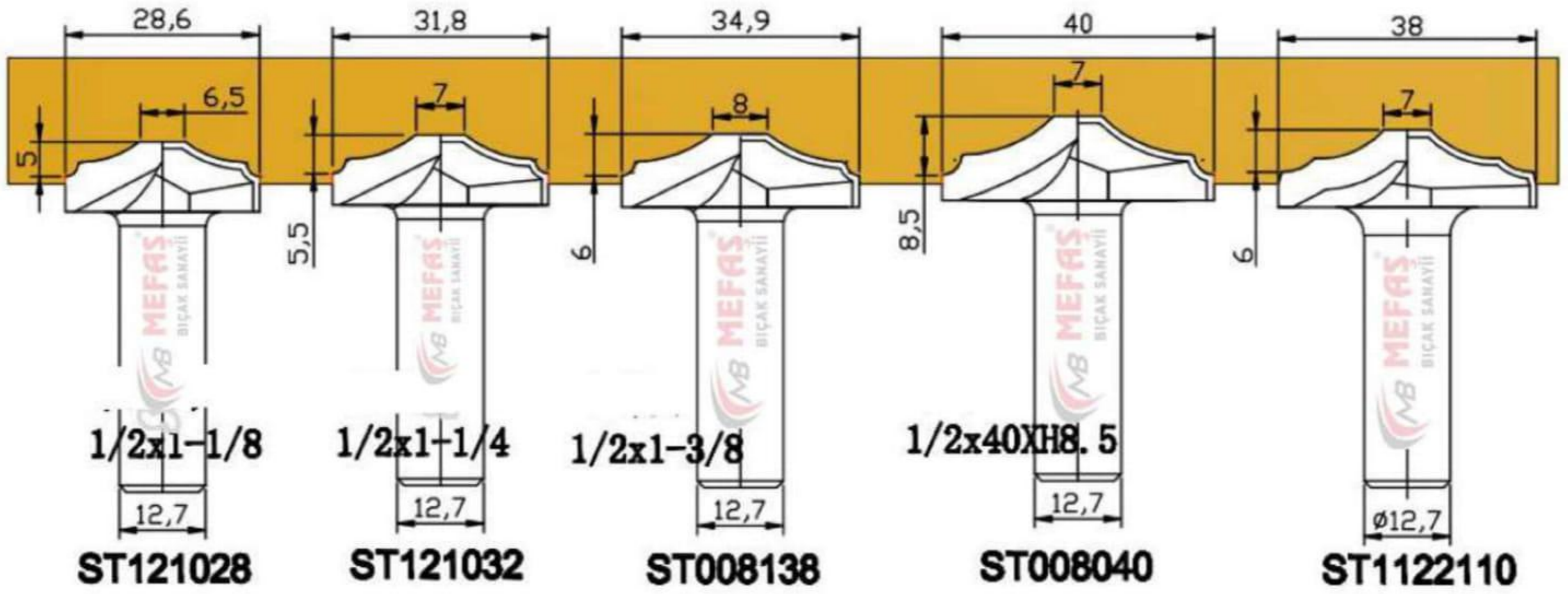

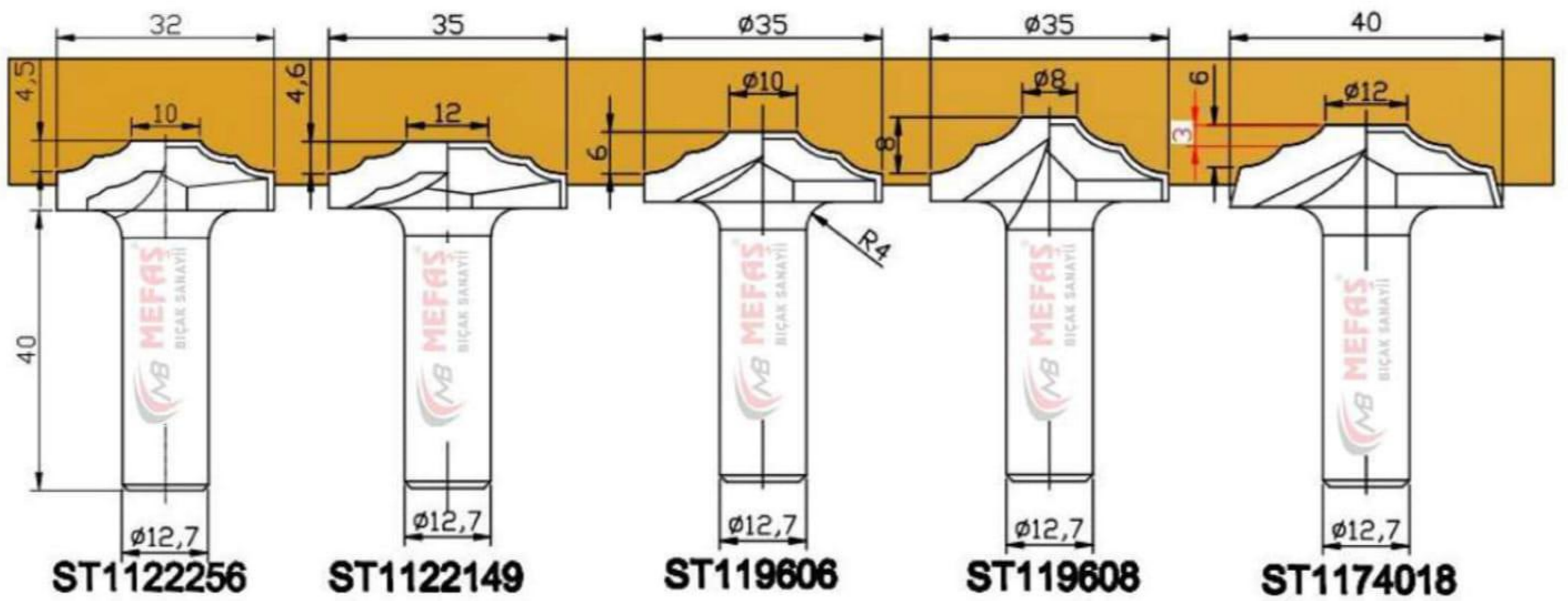
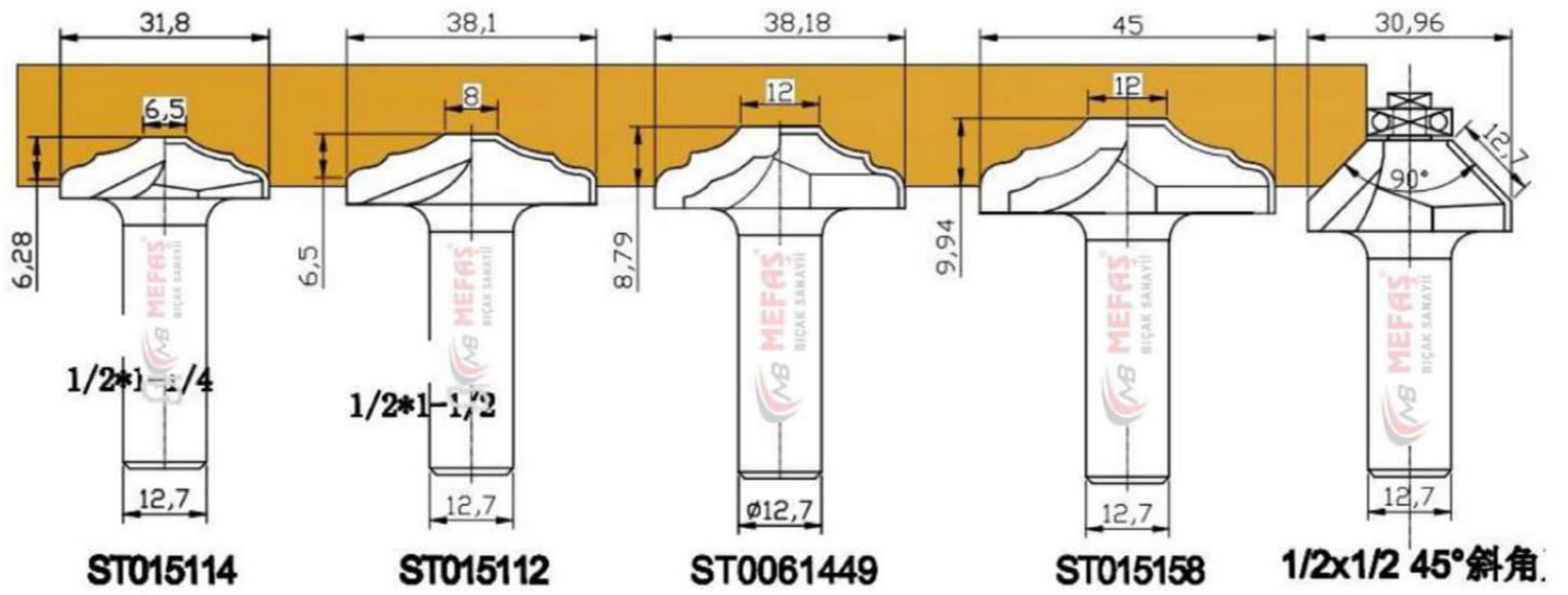
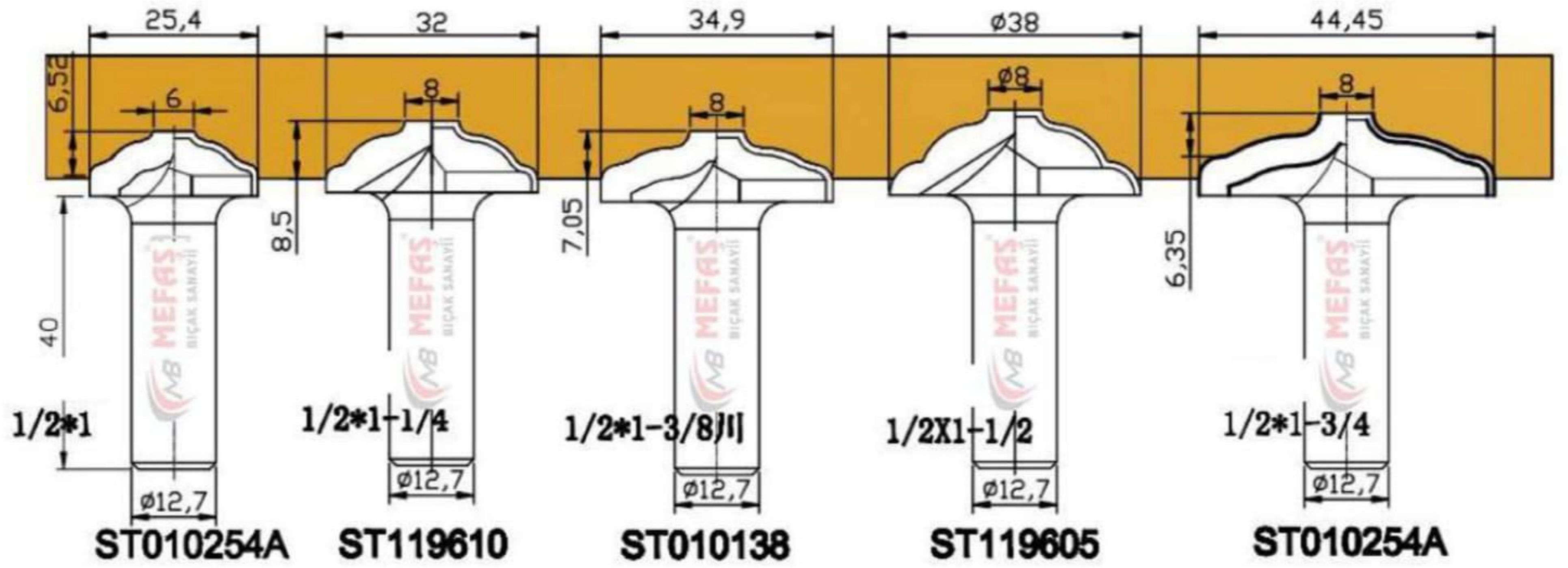

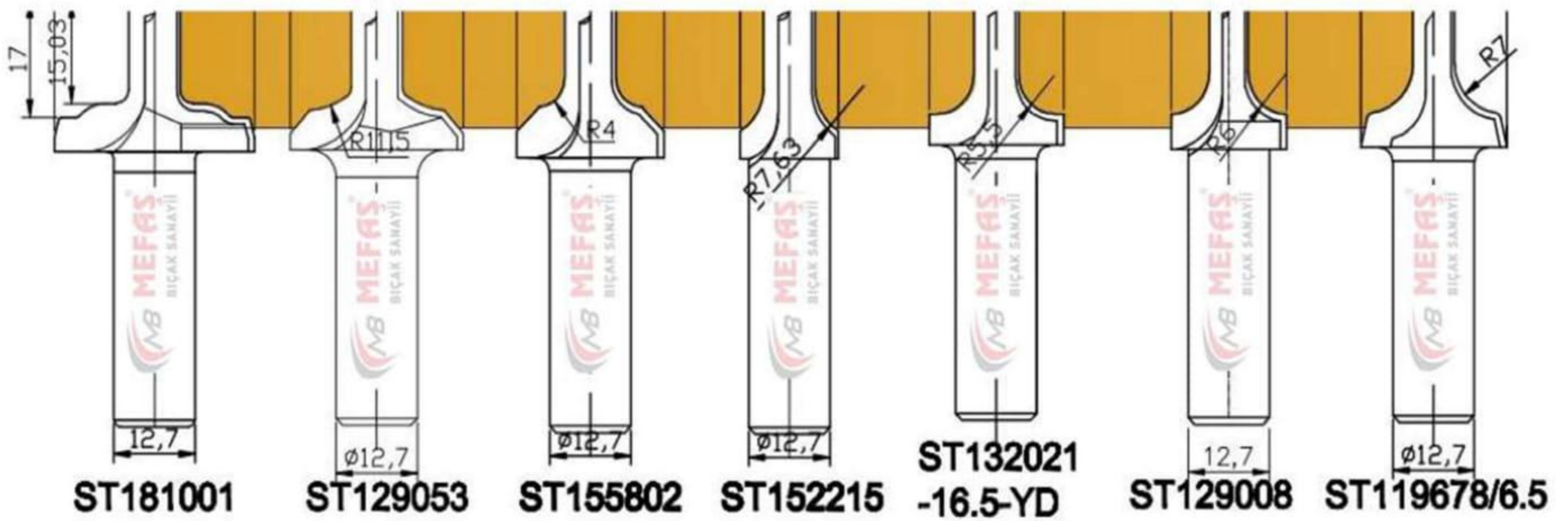
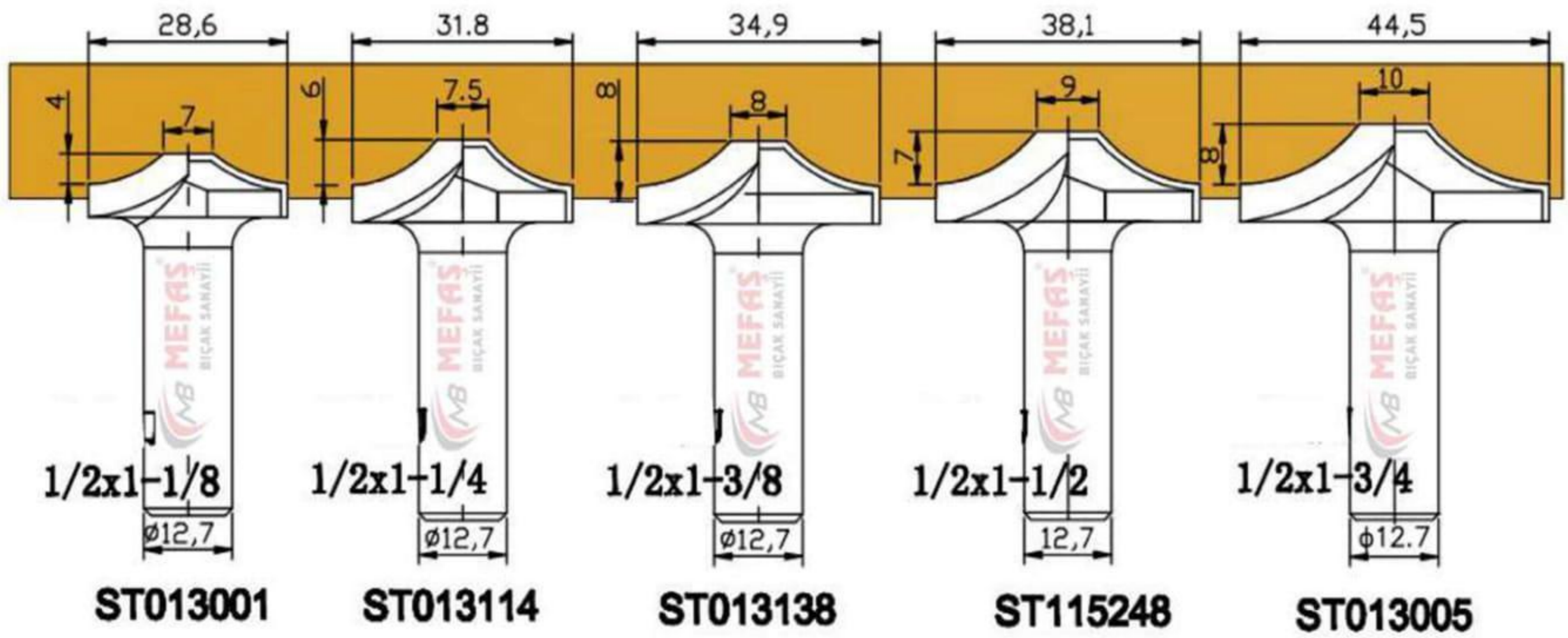
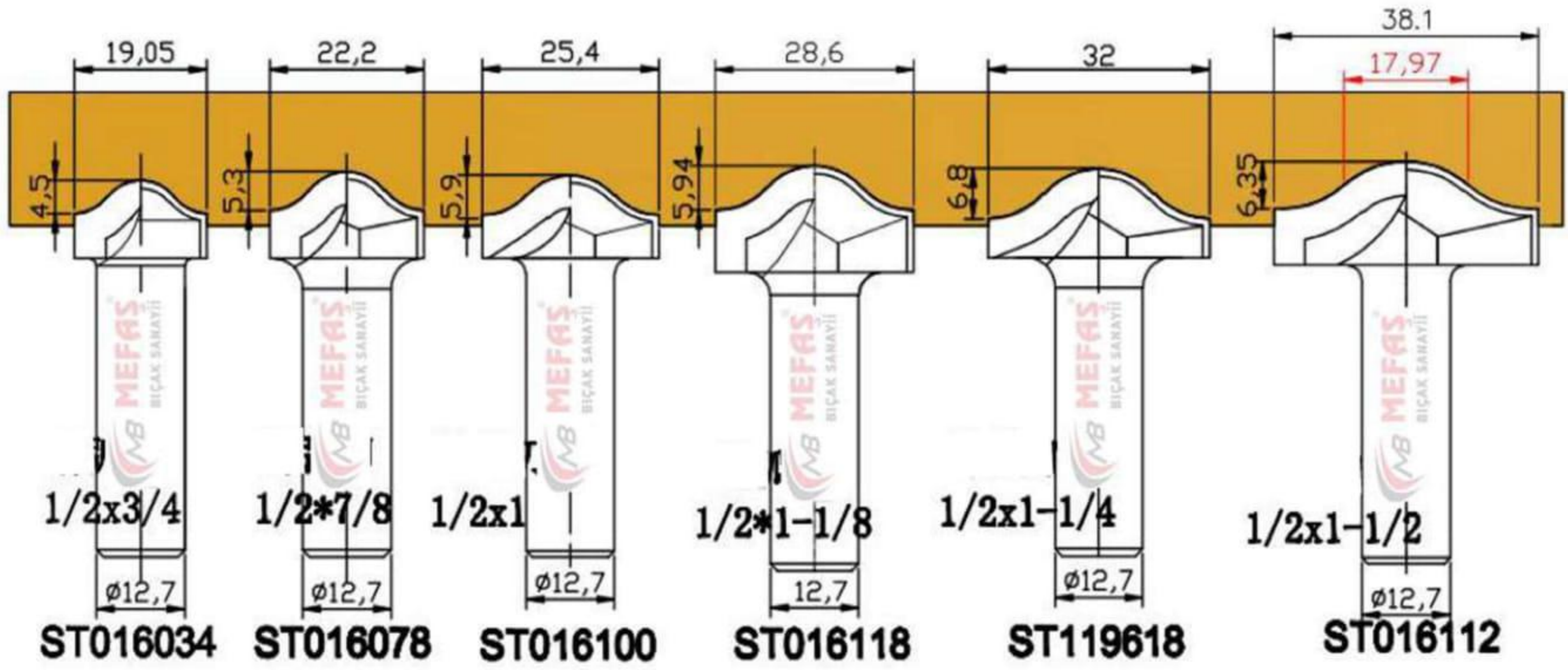

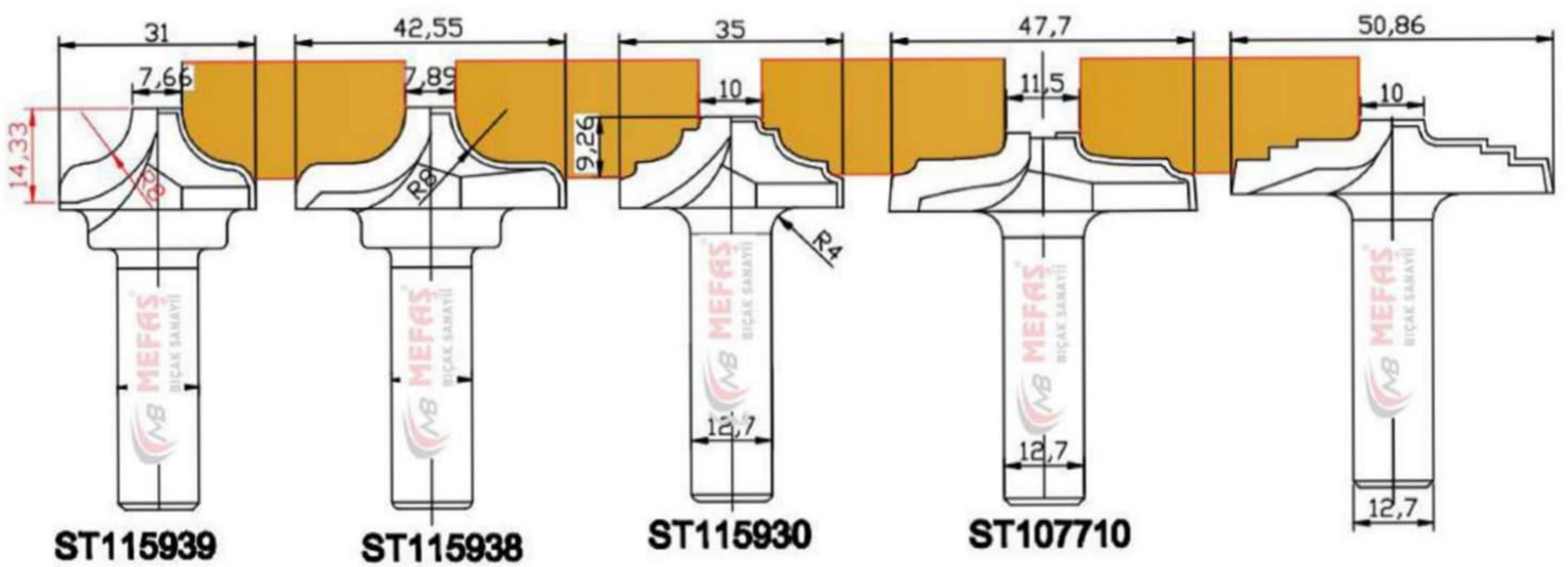
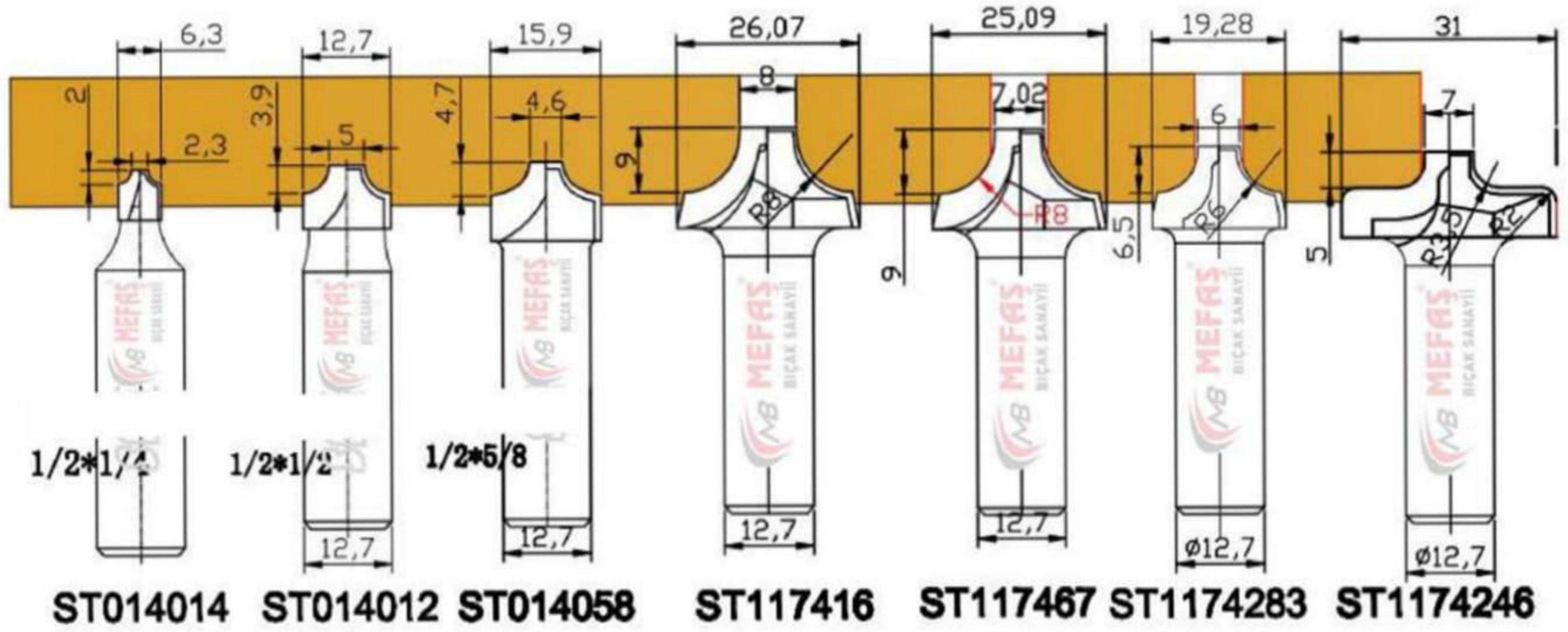
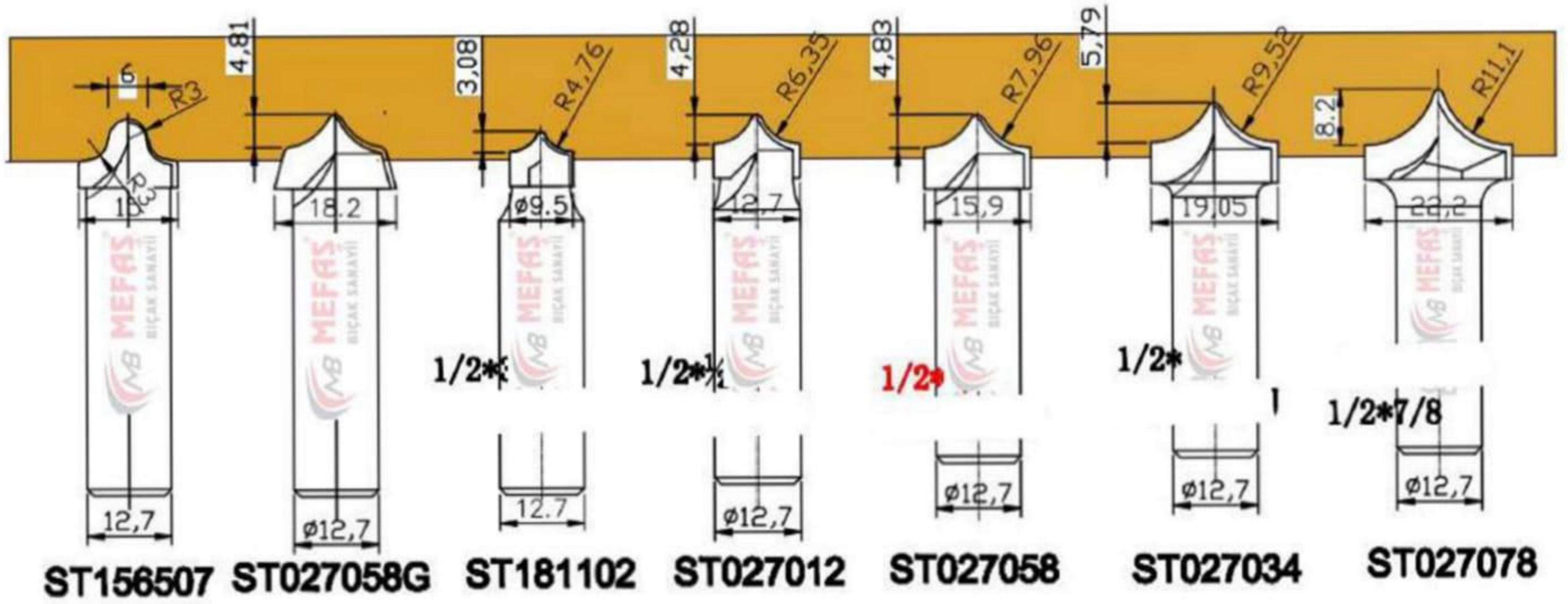

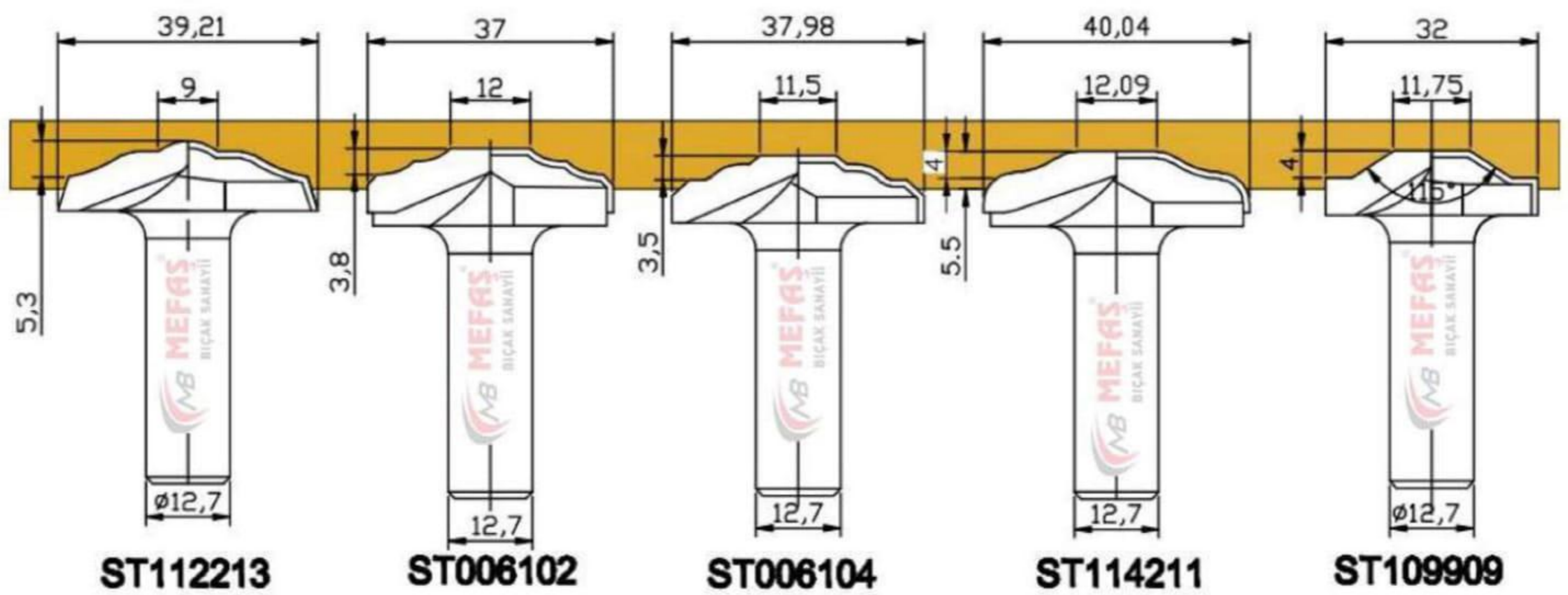
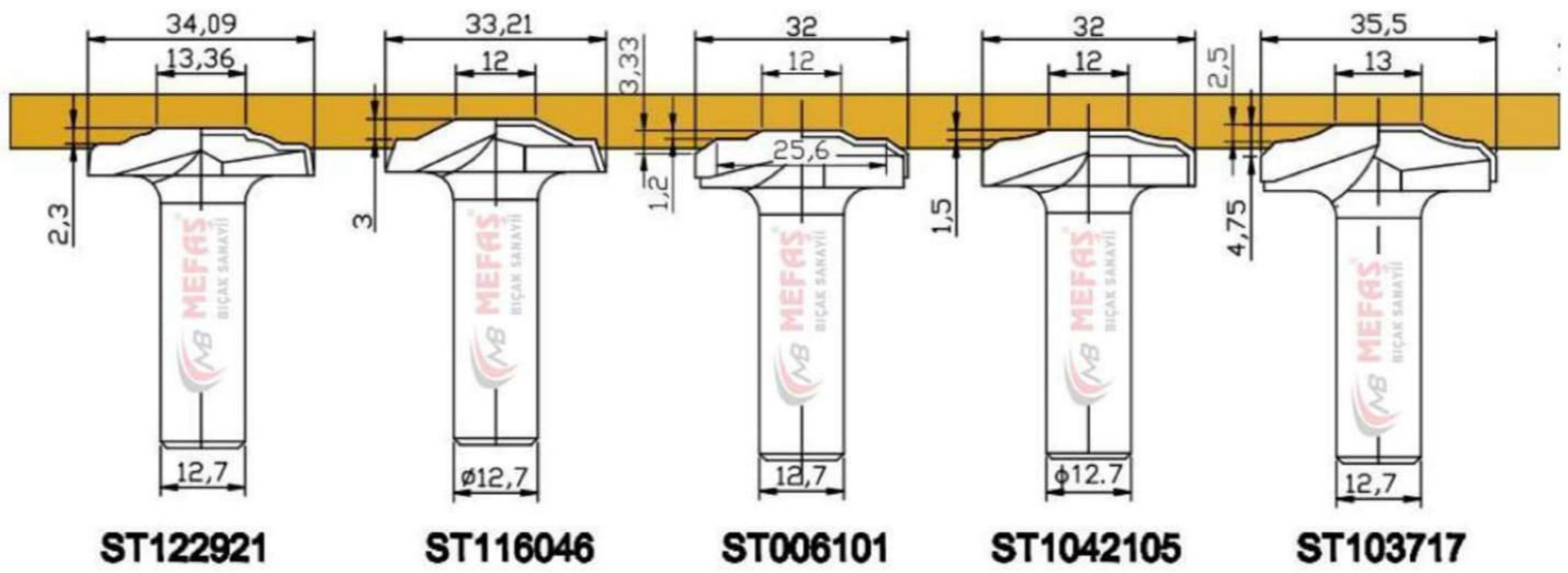
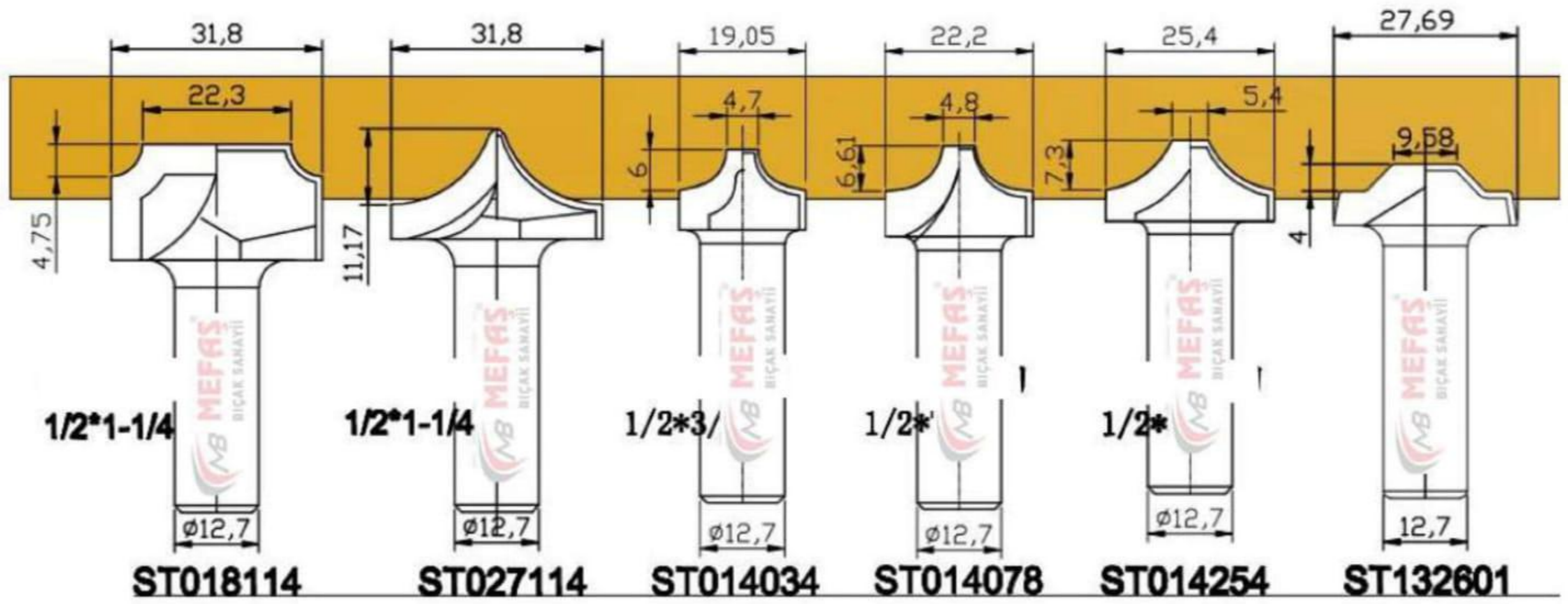

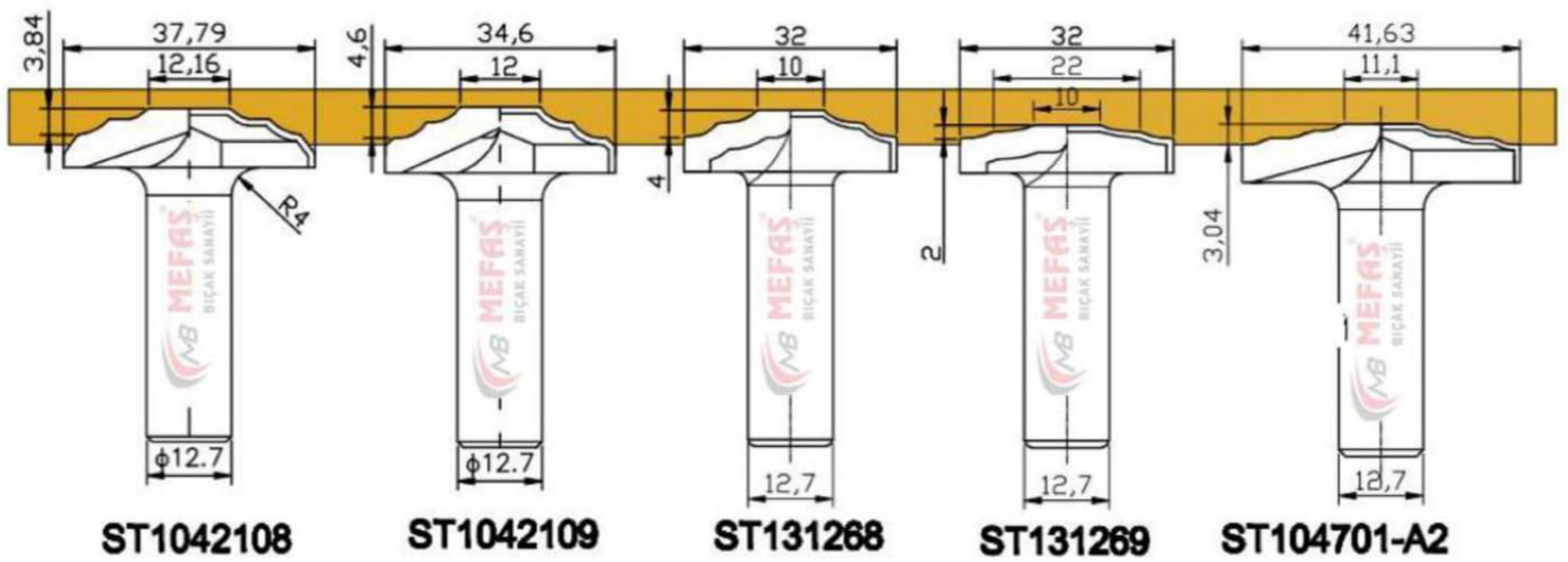
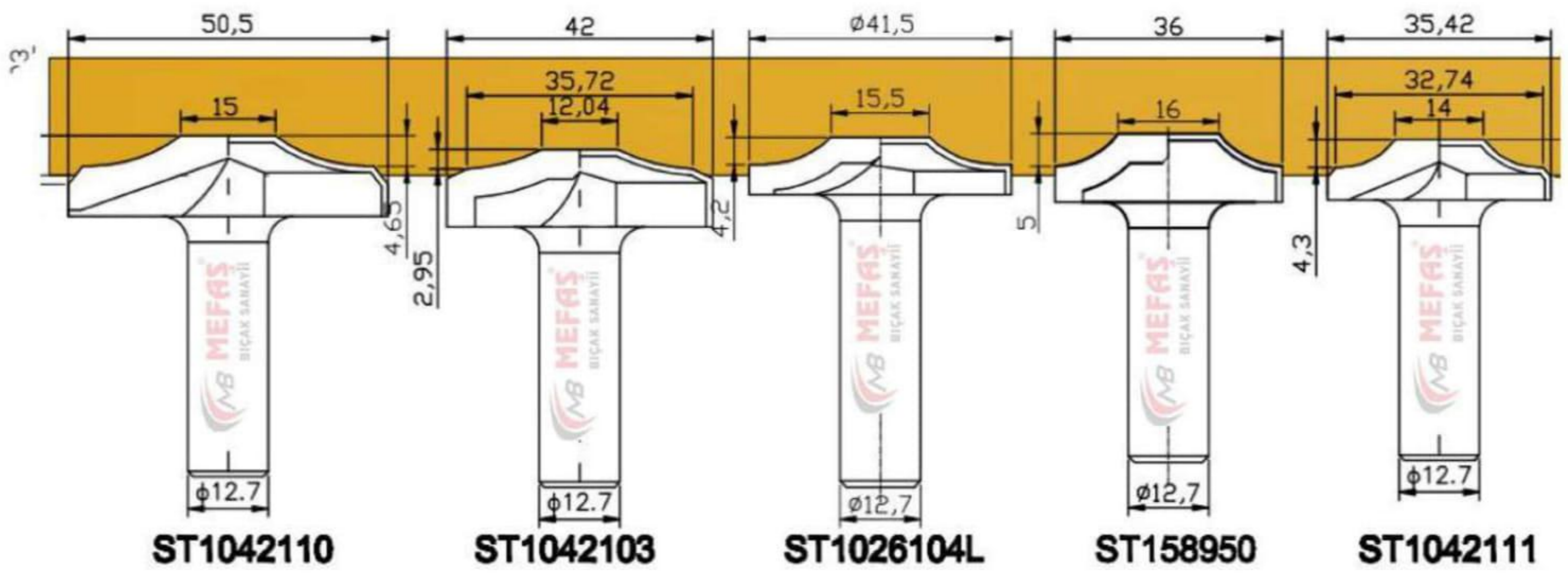
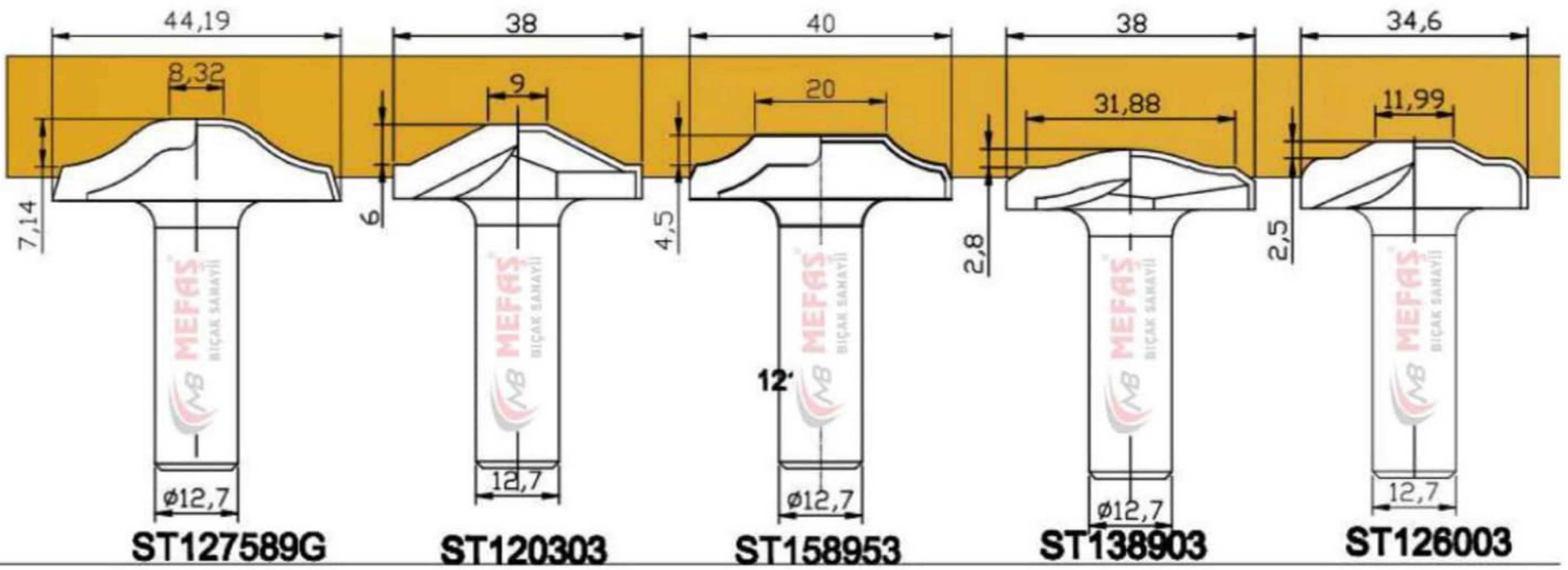

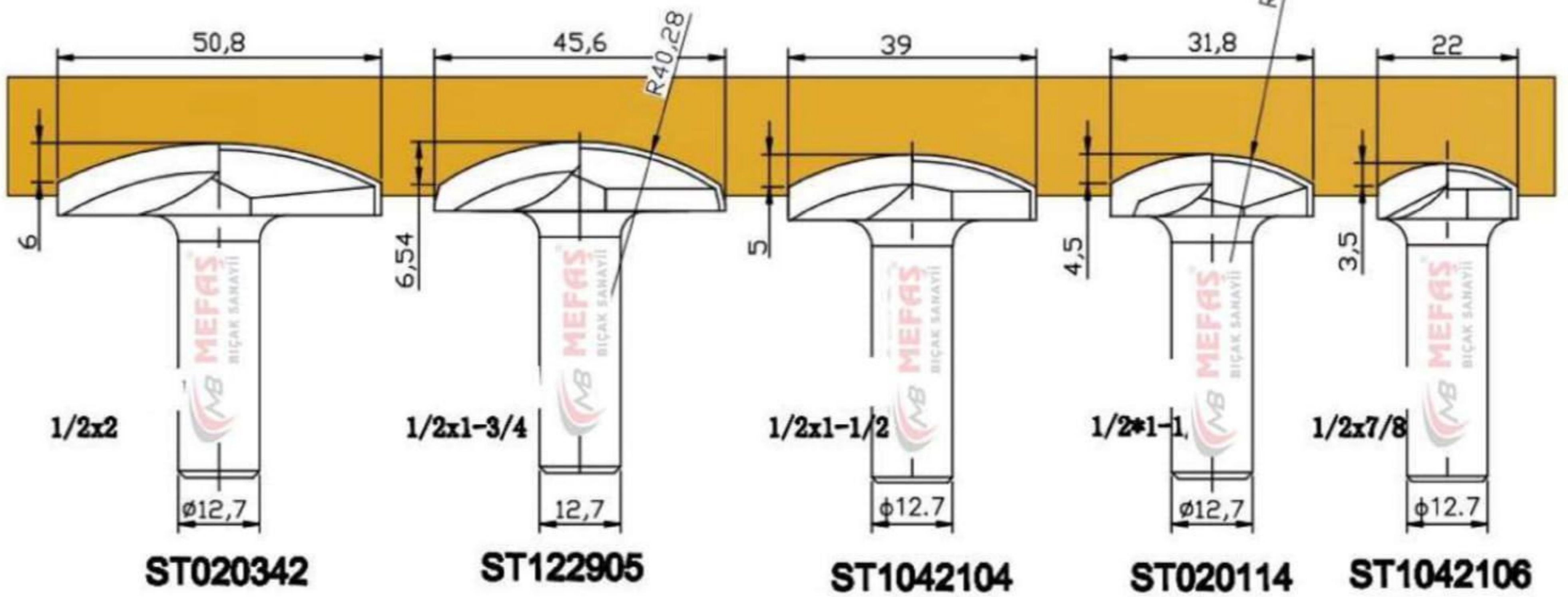
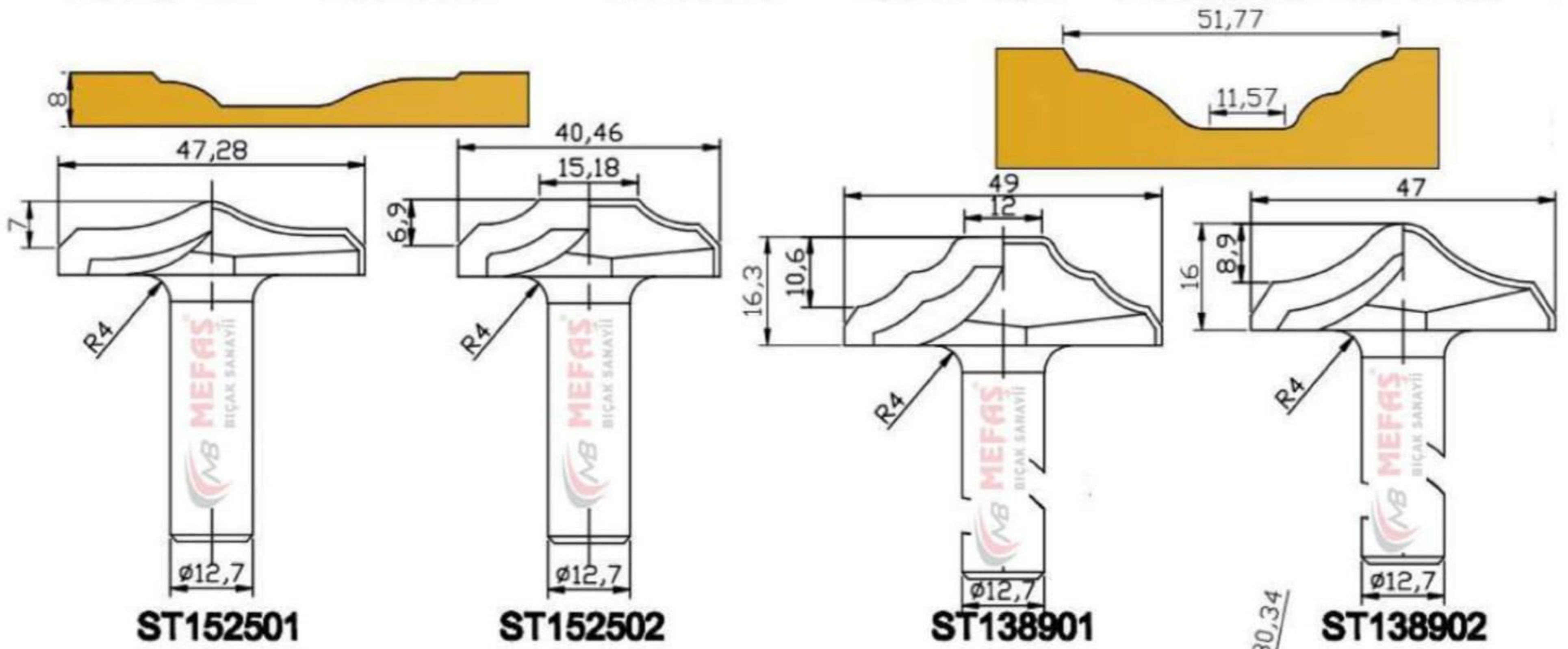
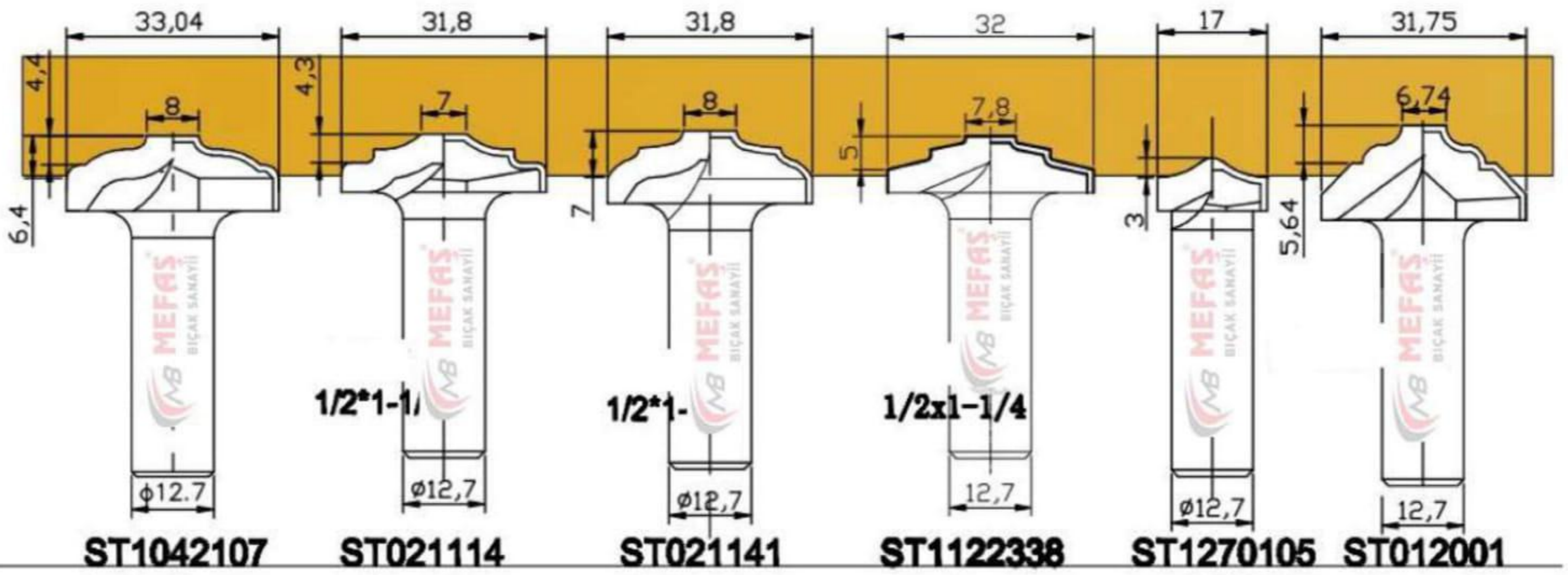

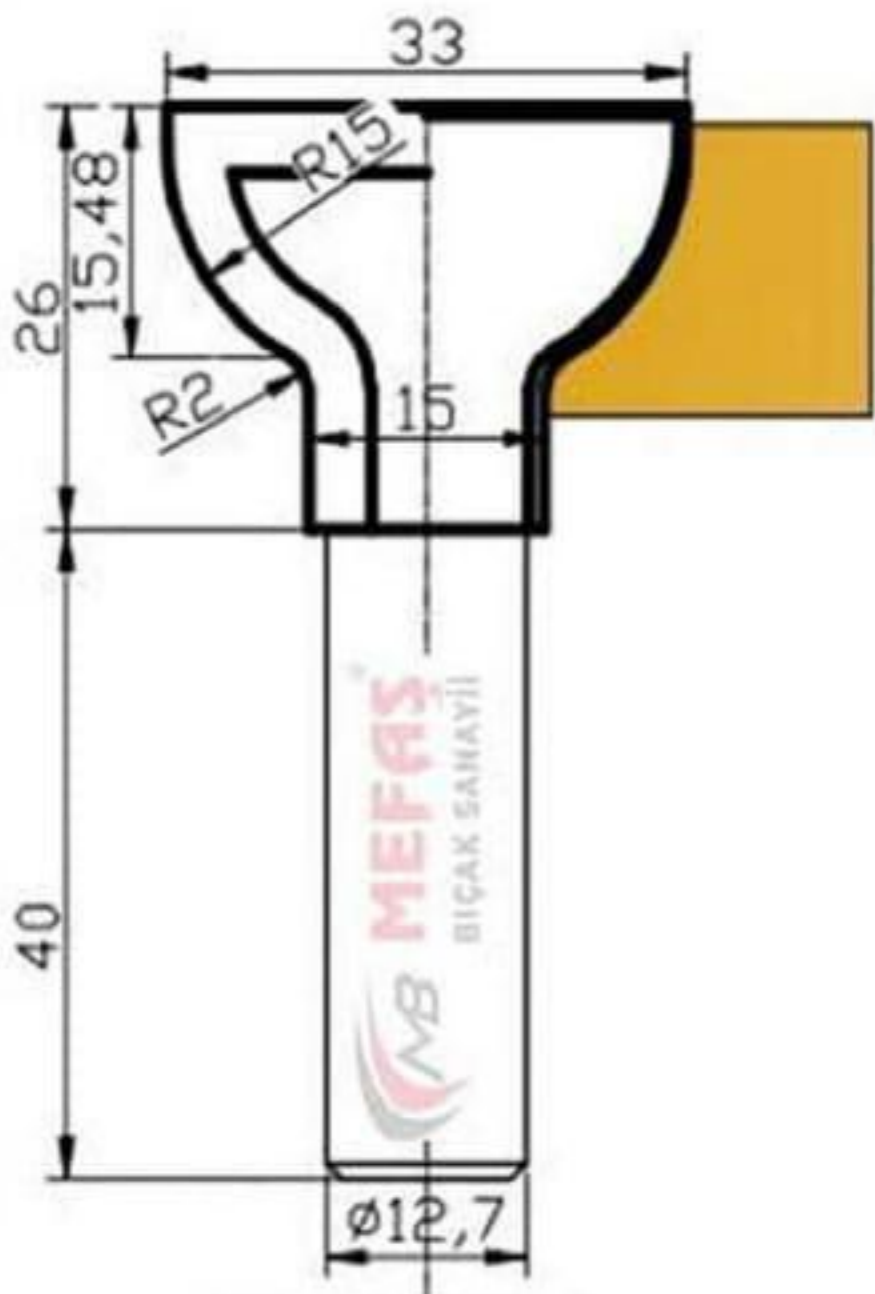
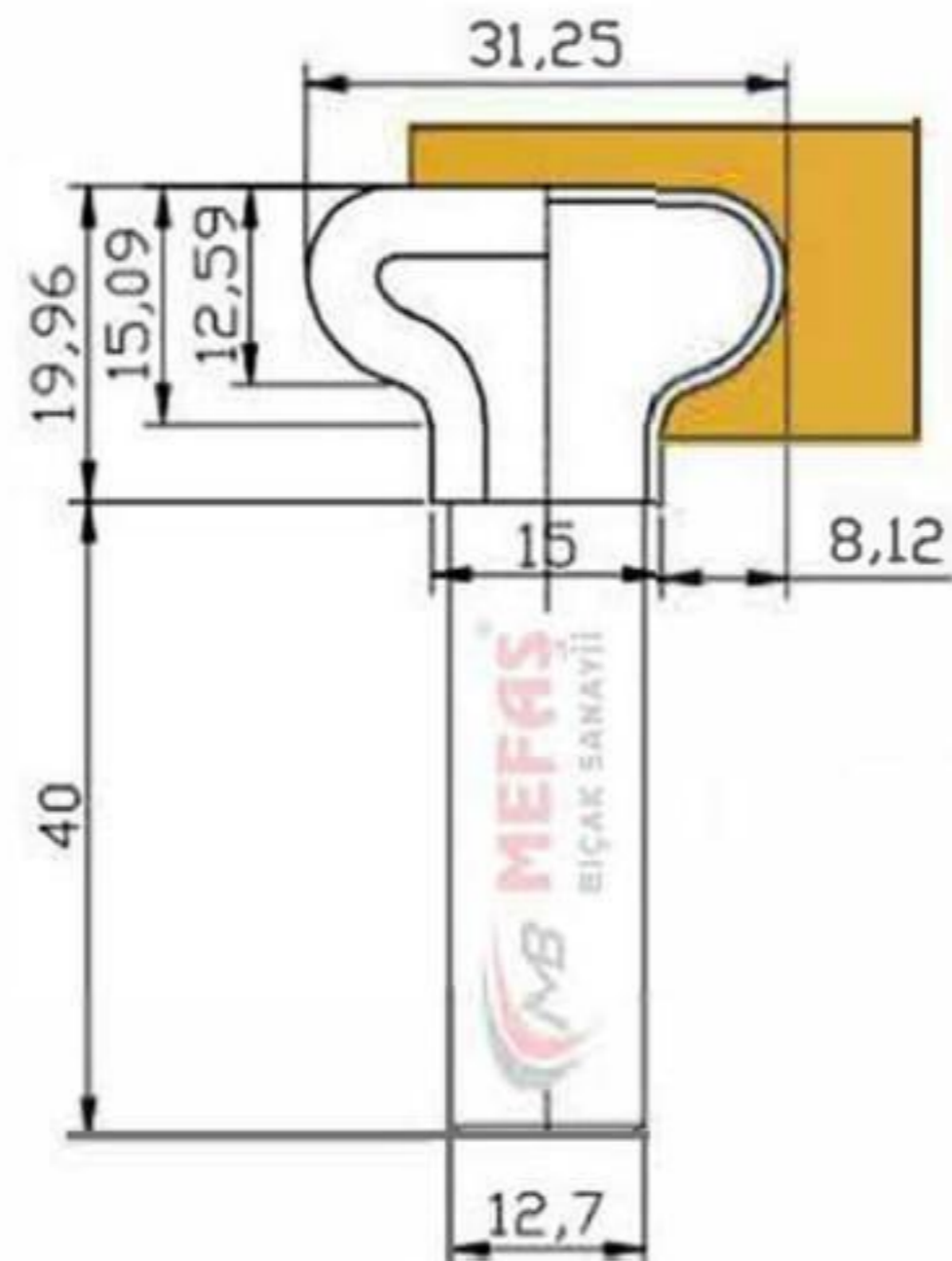
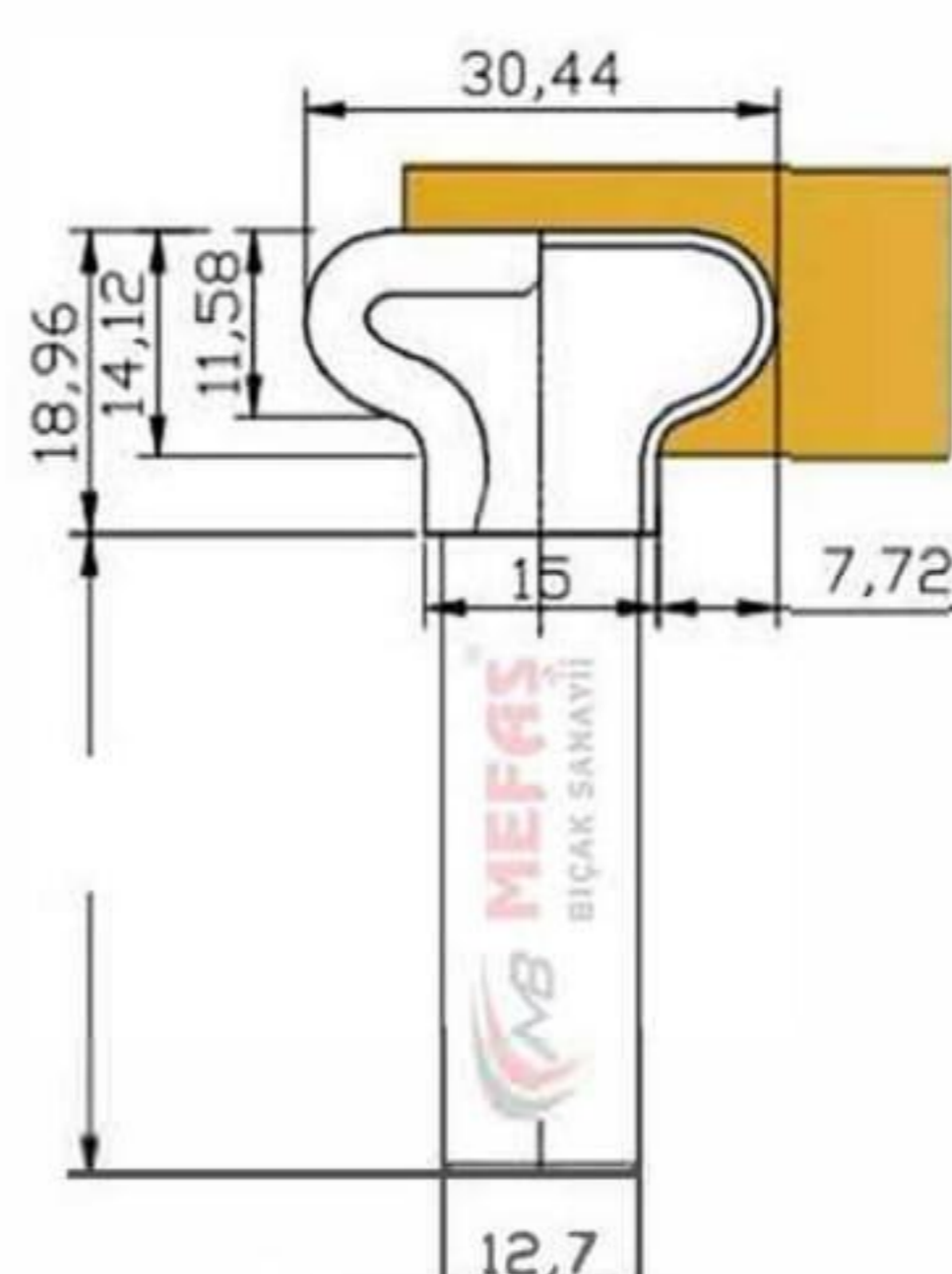
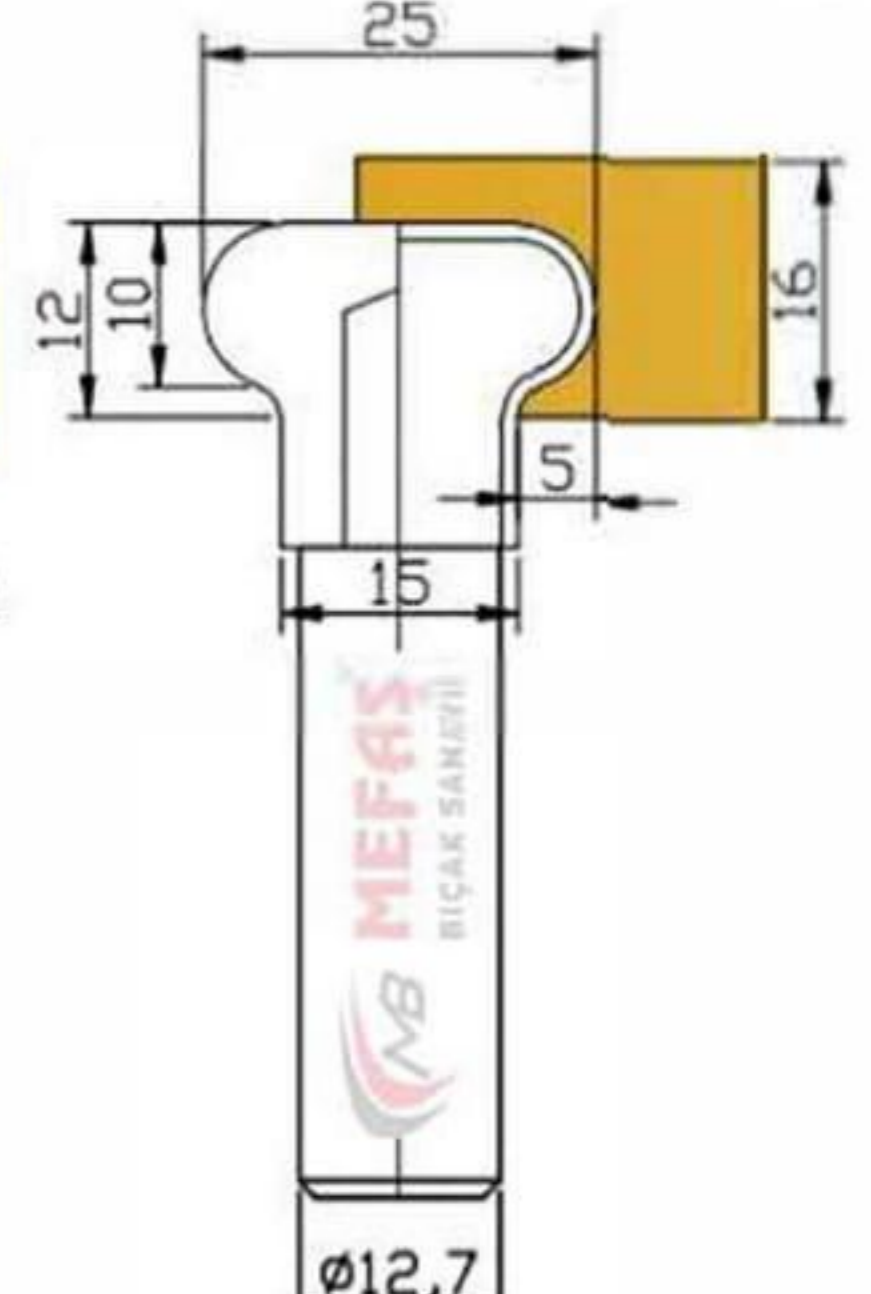
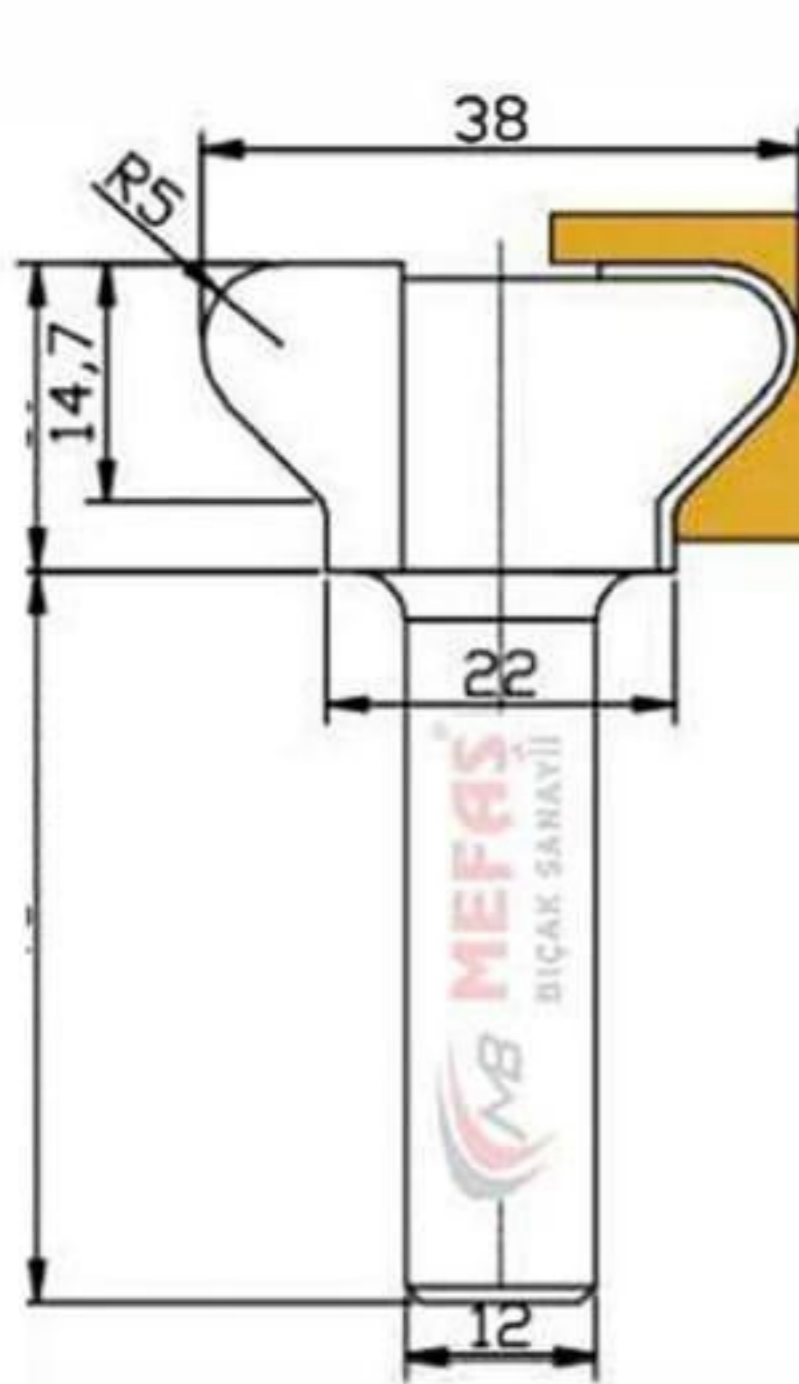
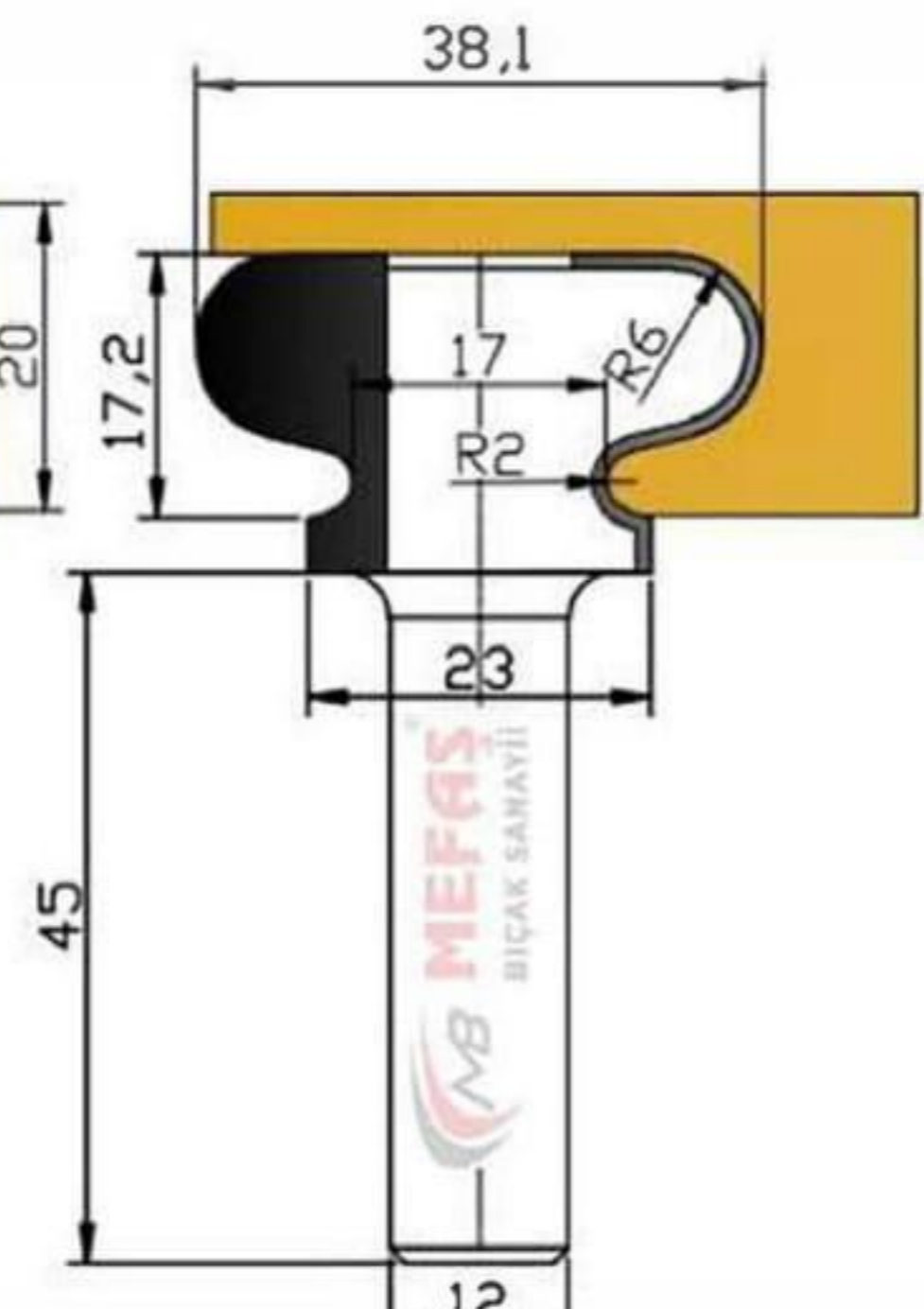
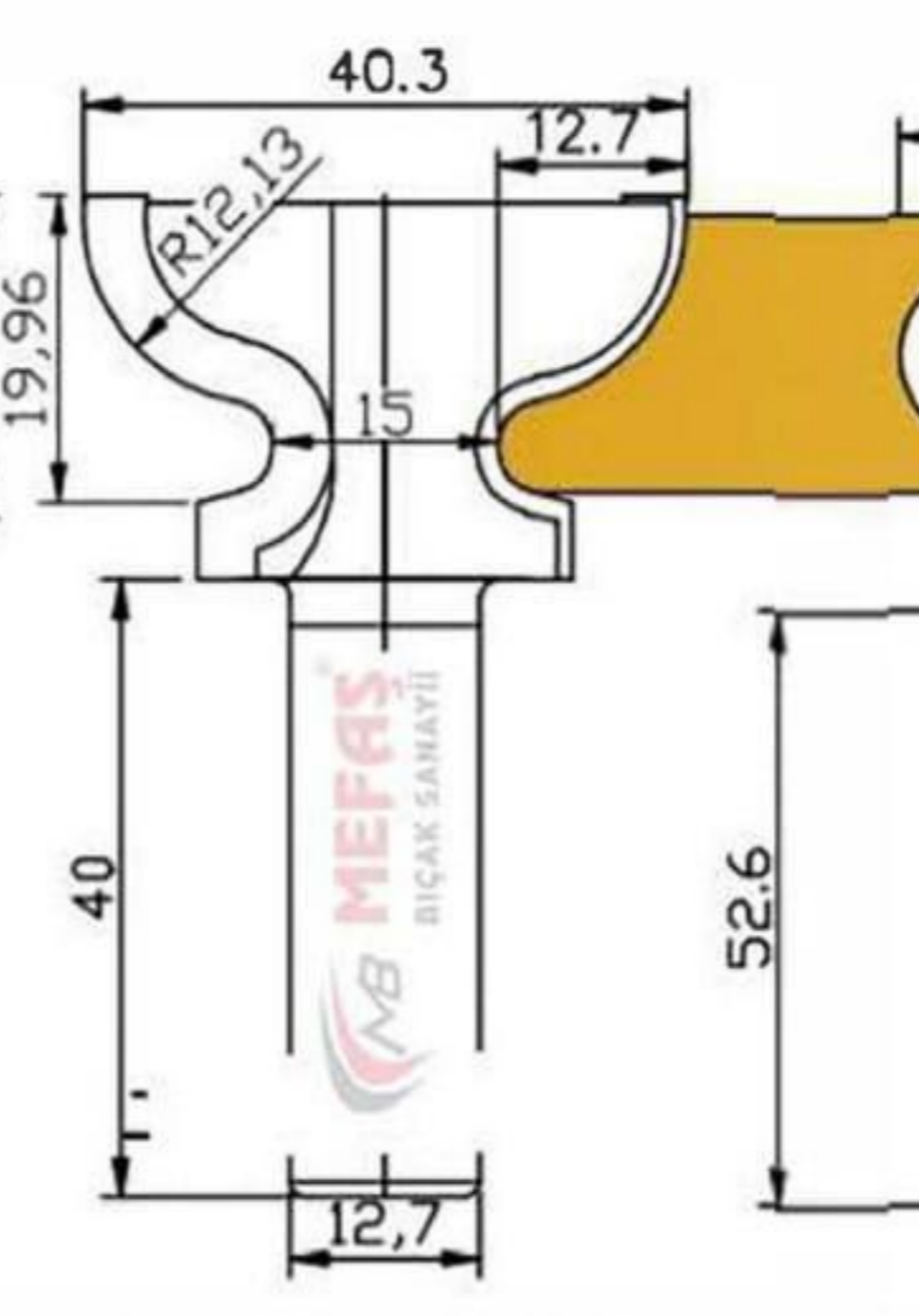
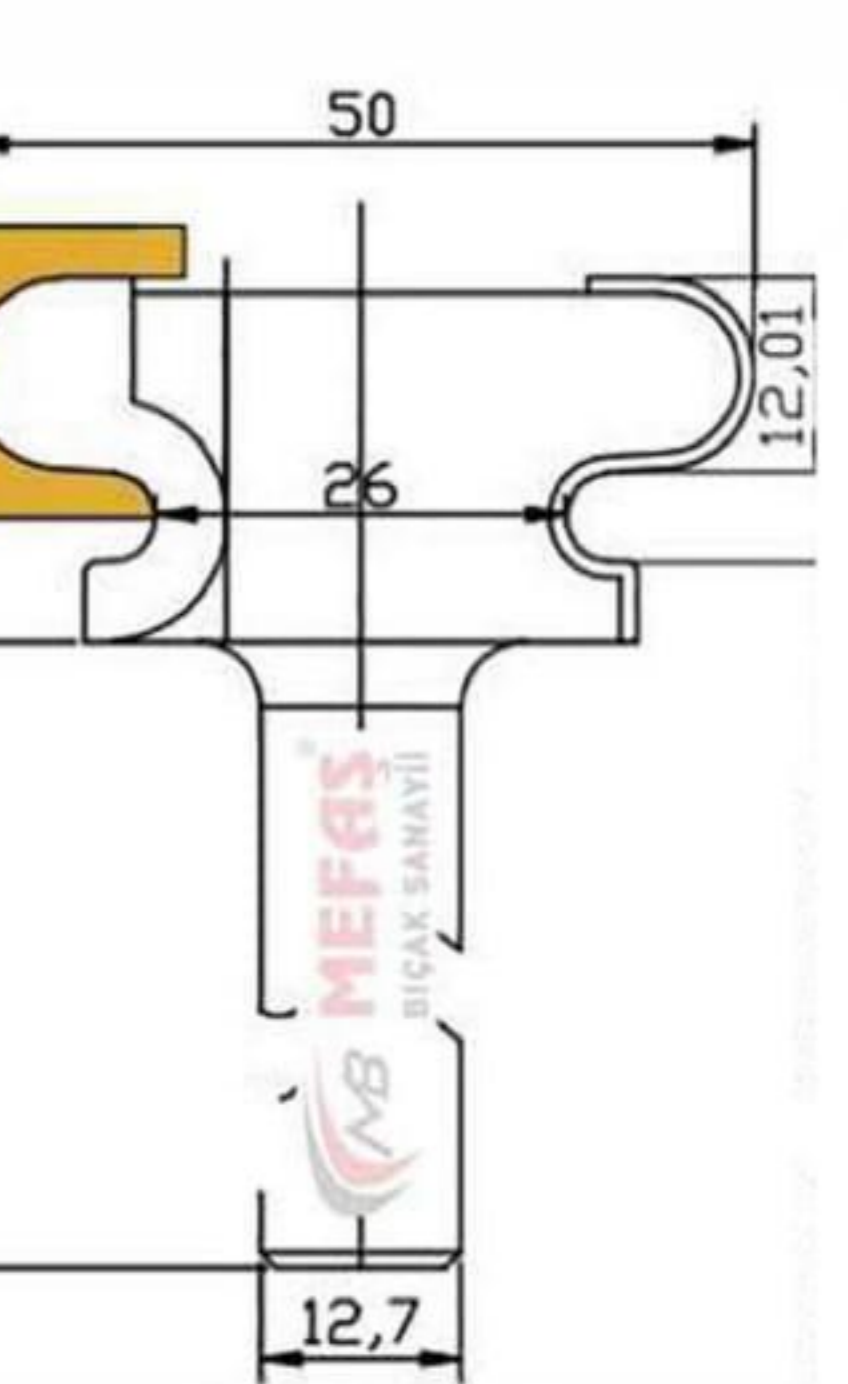
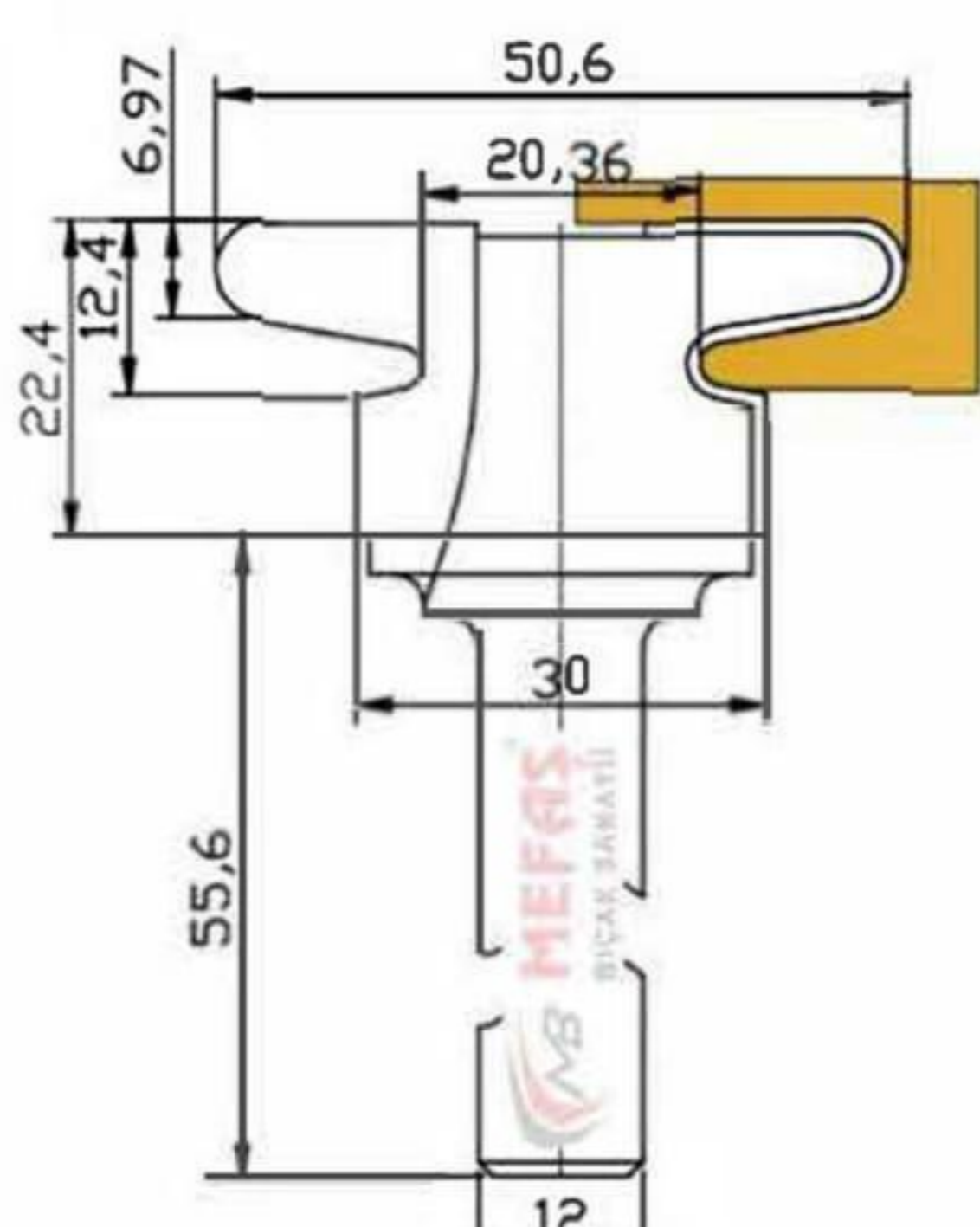
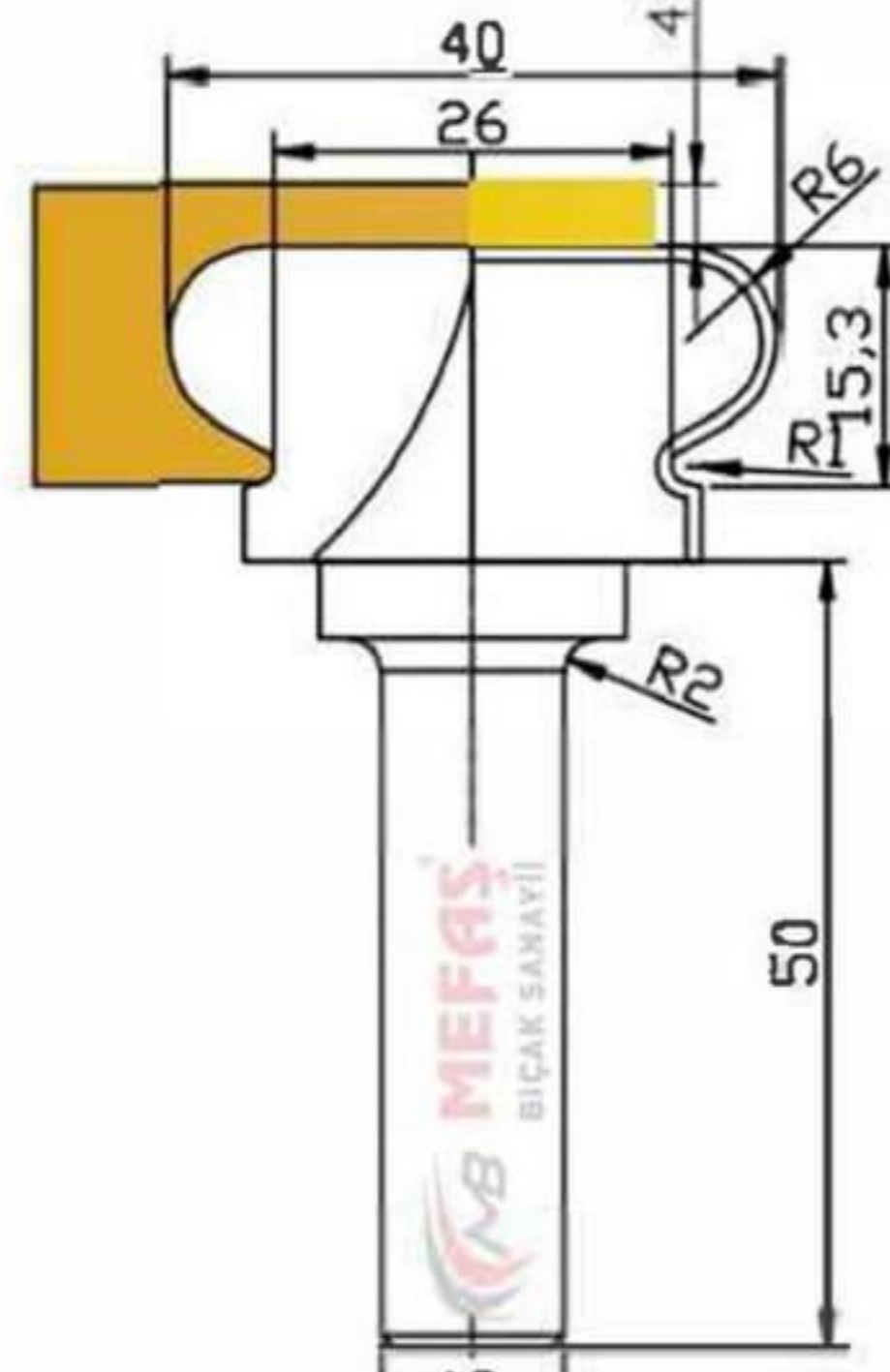
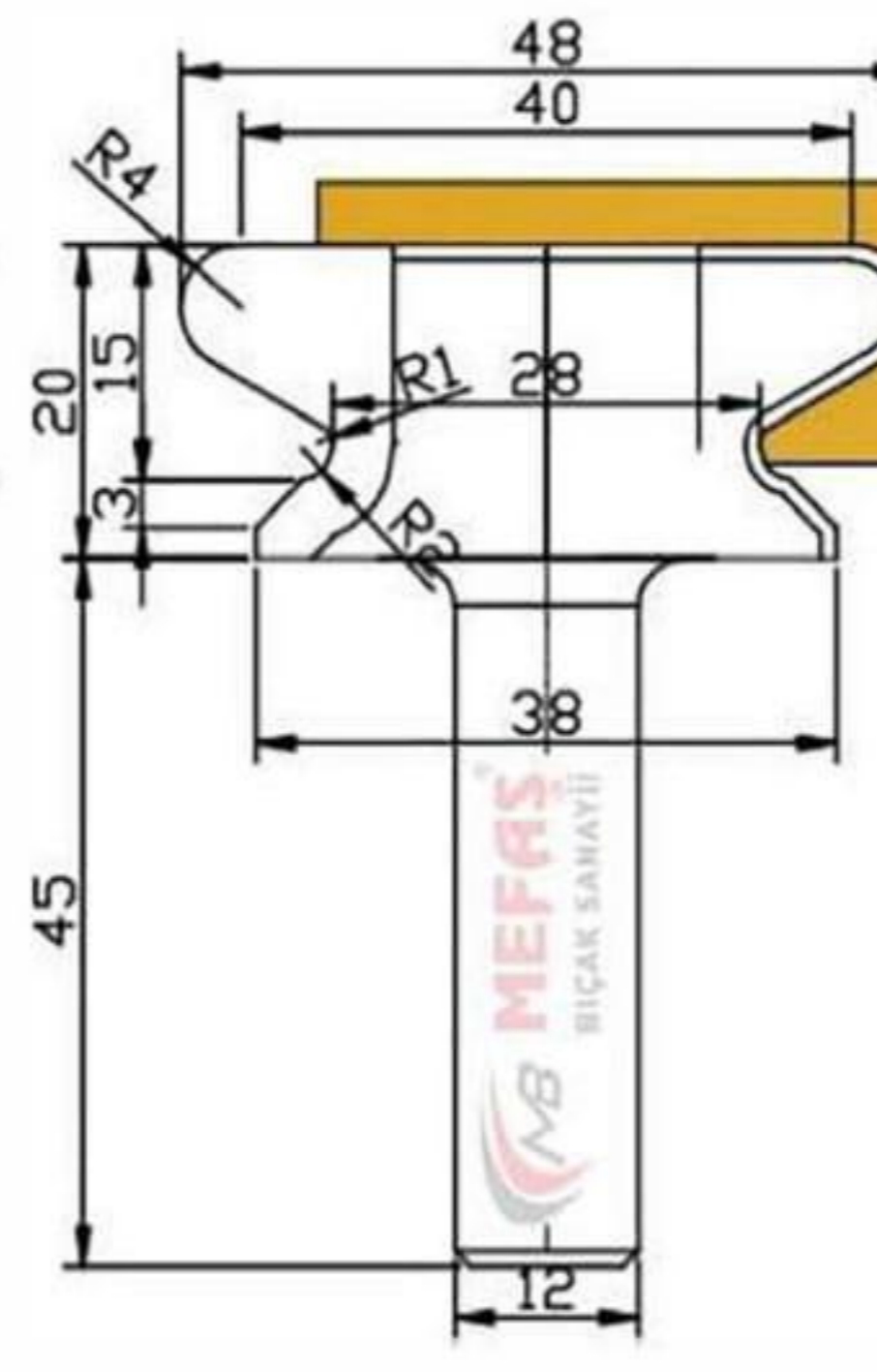
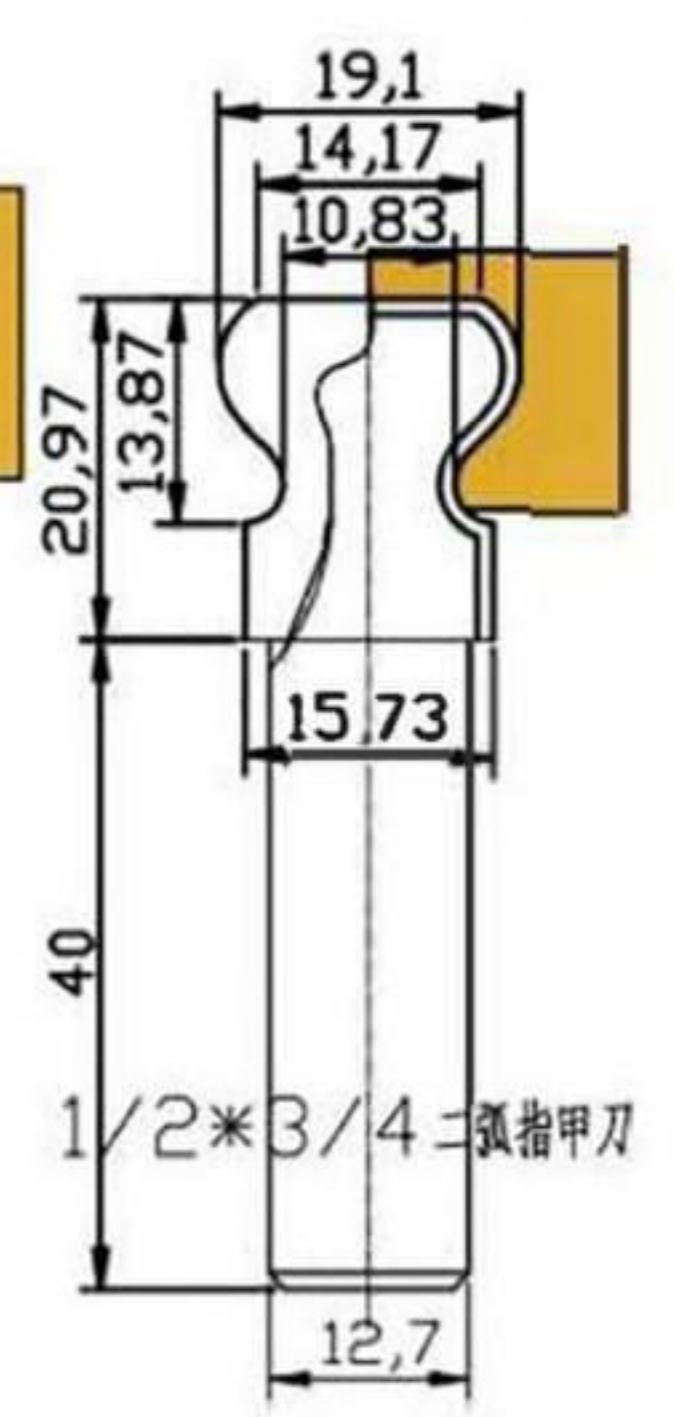

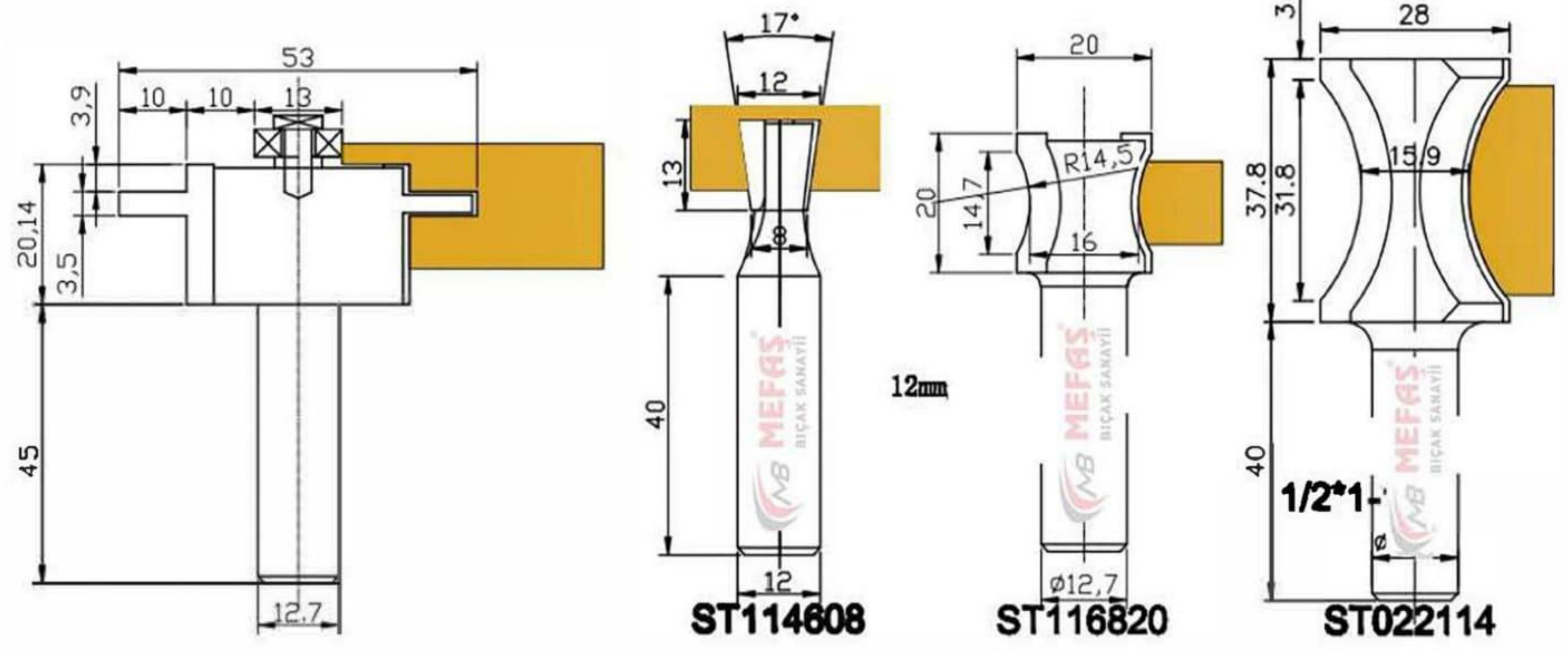
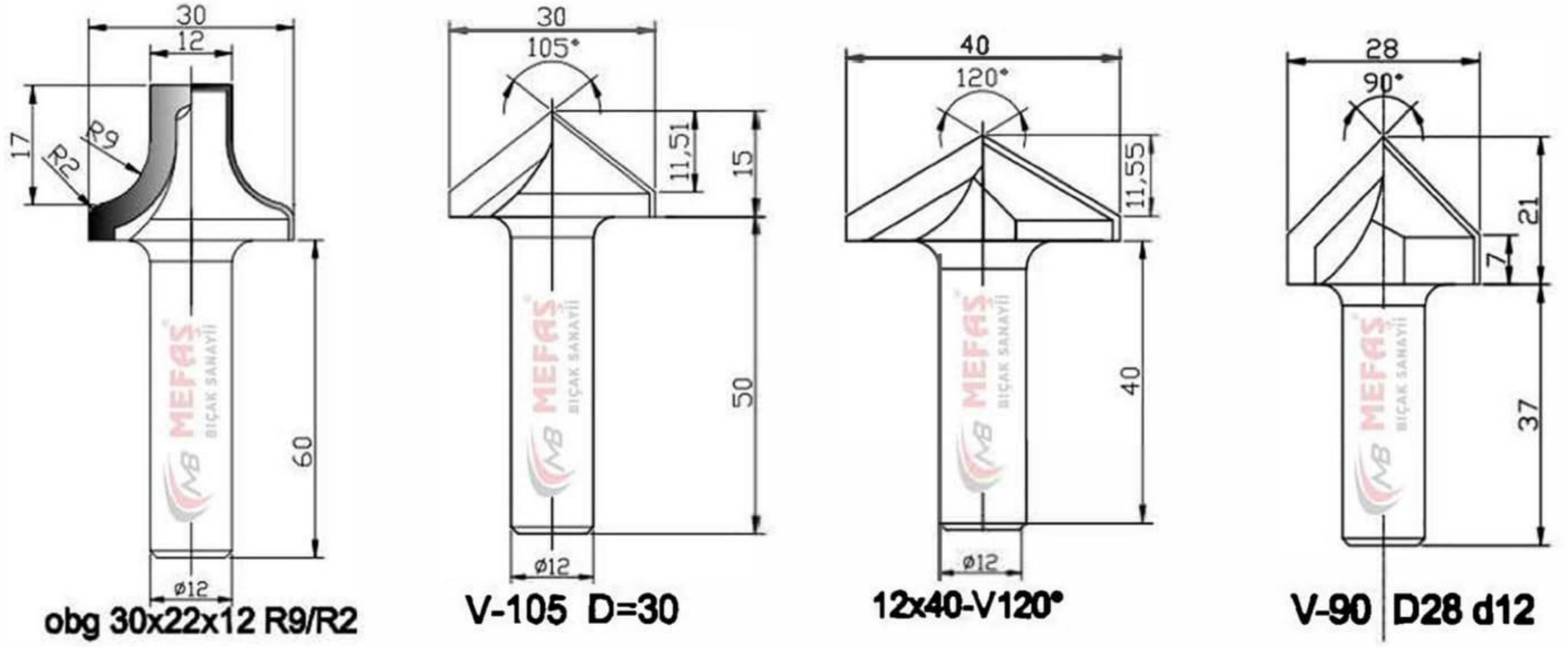
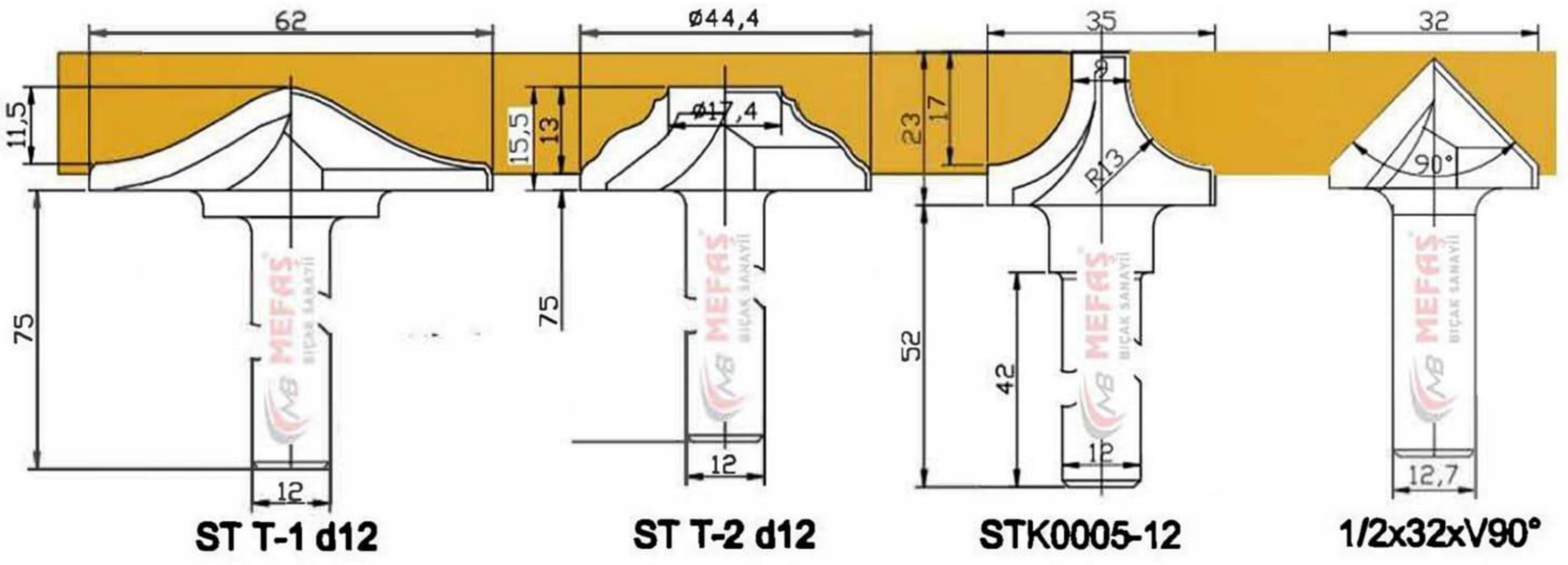
ST1026889

ST1174398-20

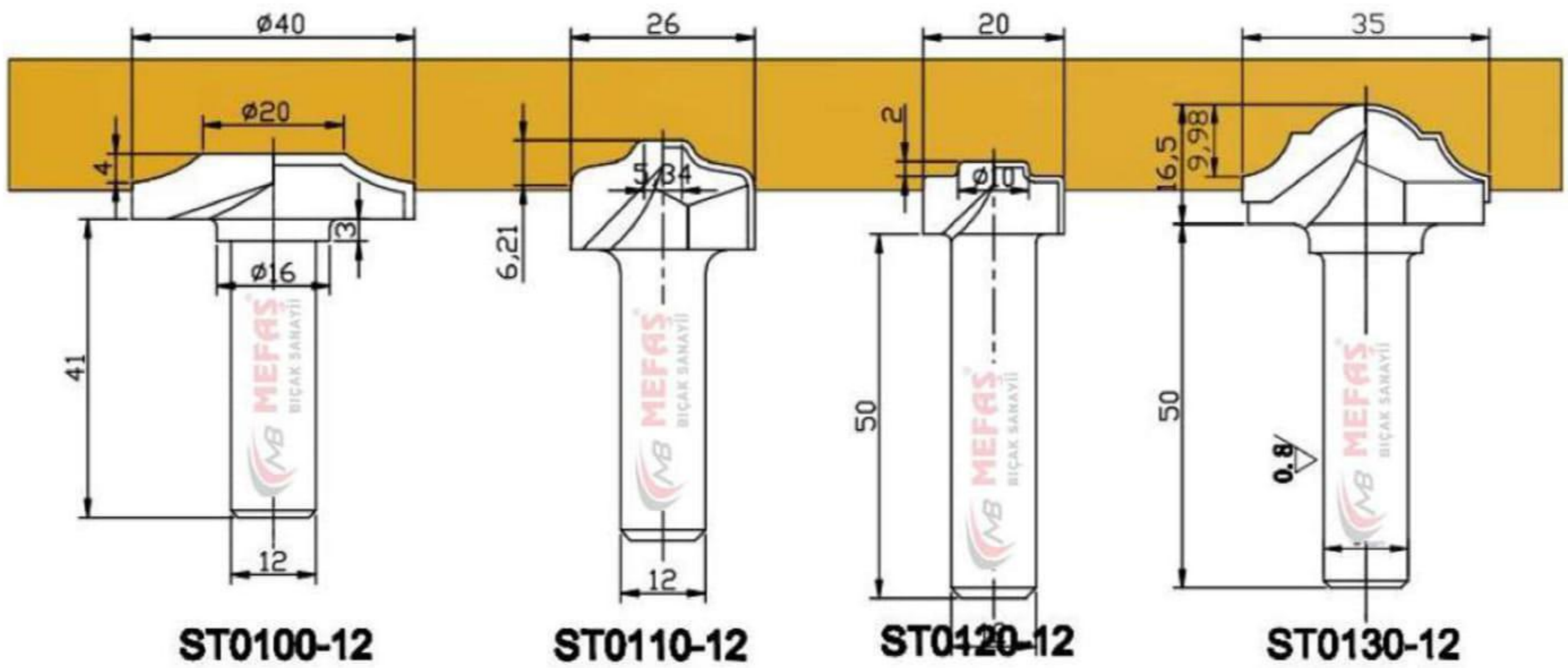
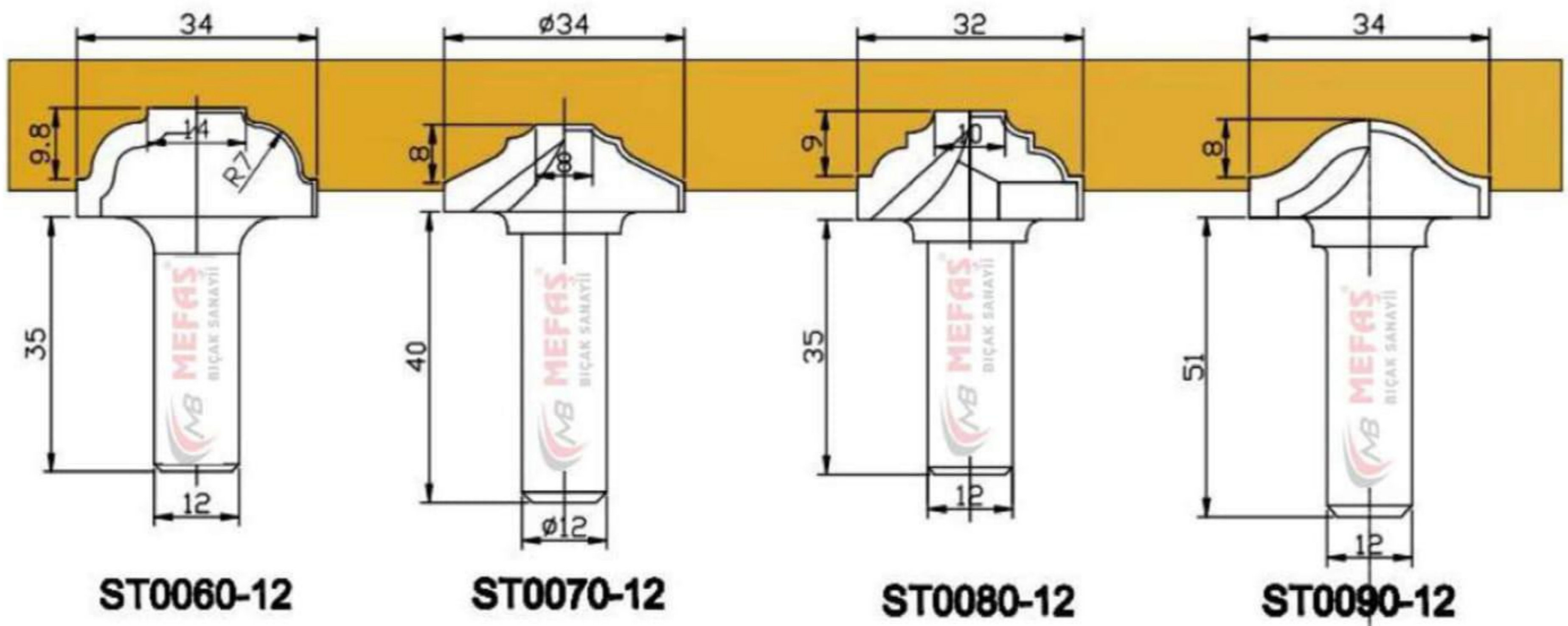
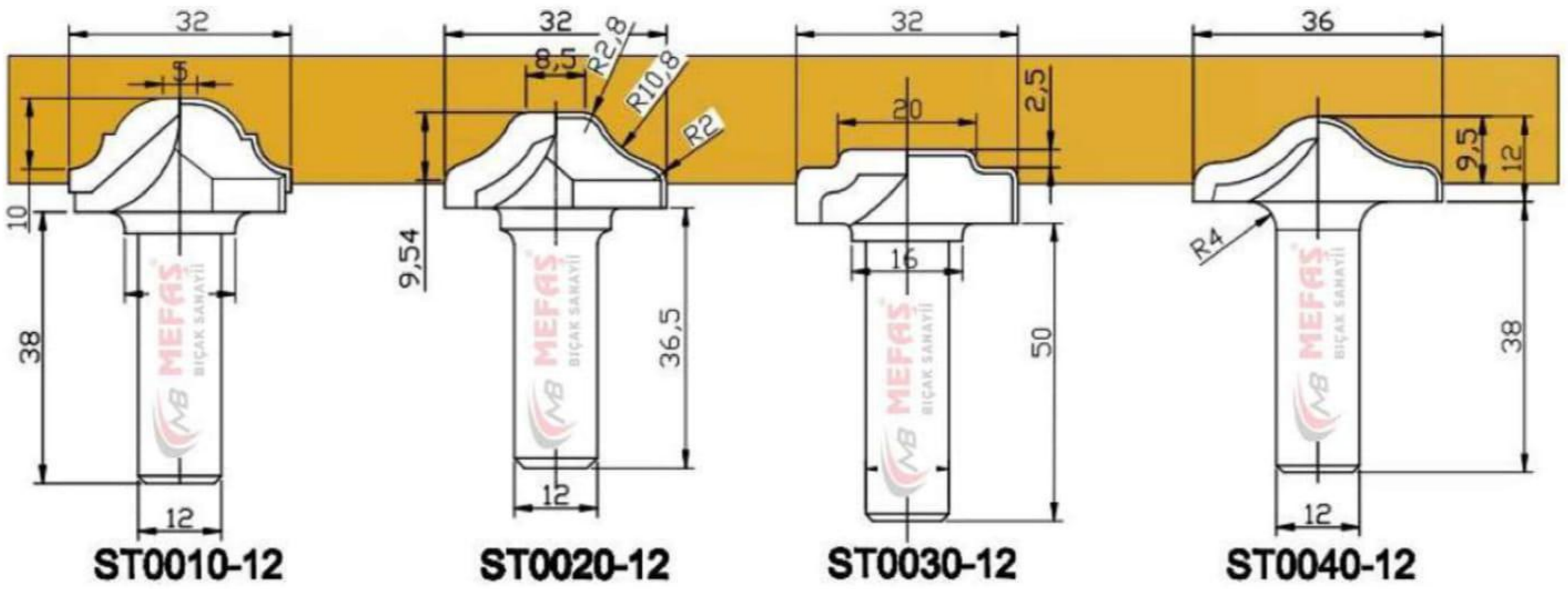
ST1174574-18

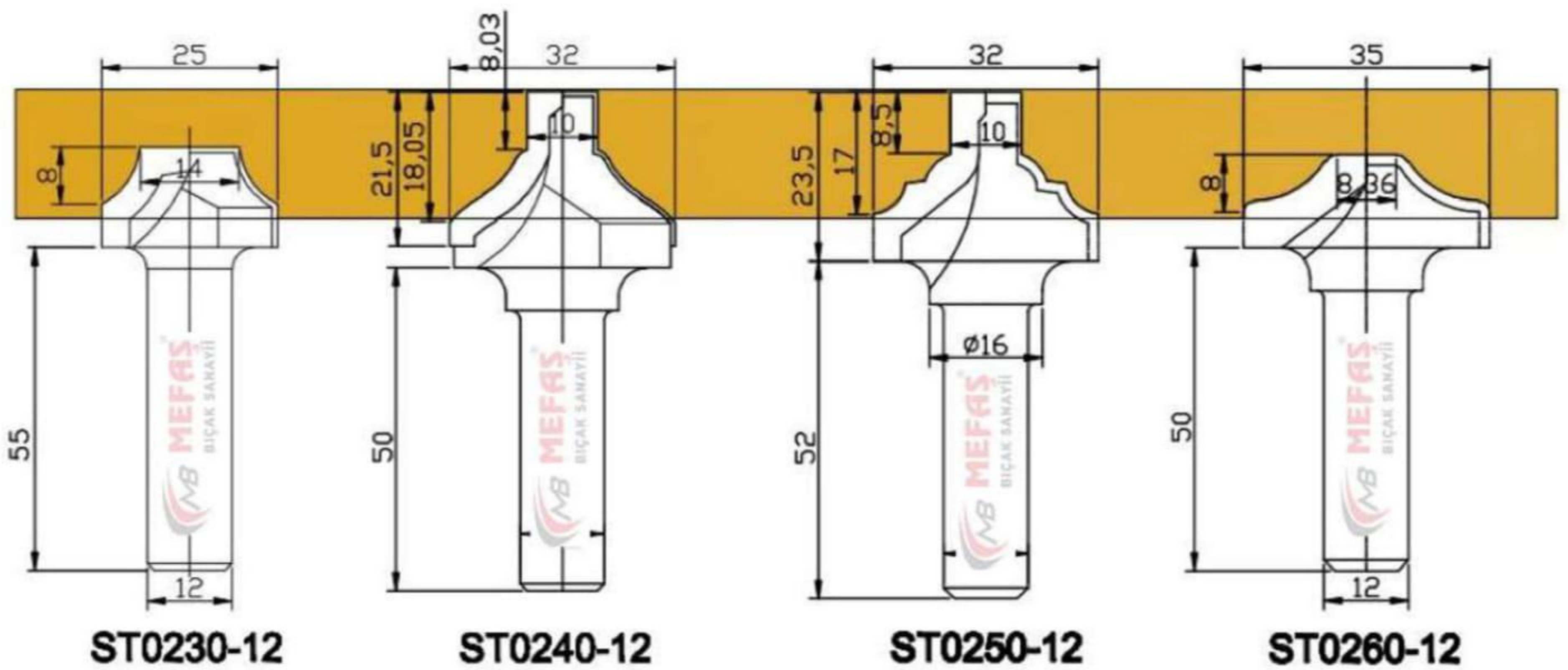
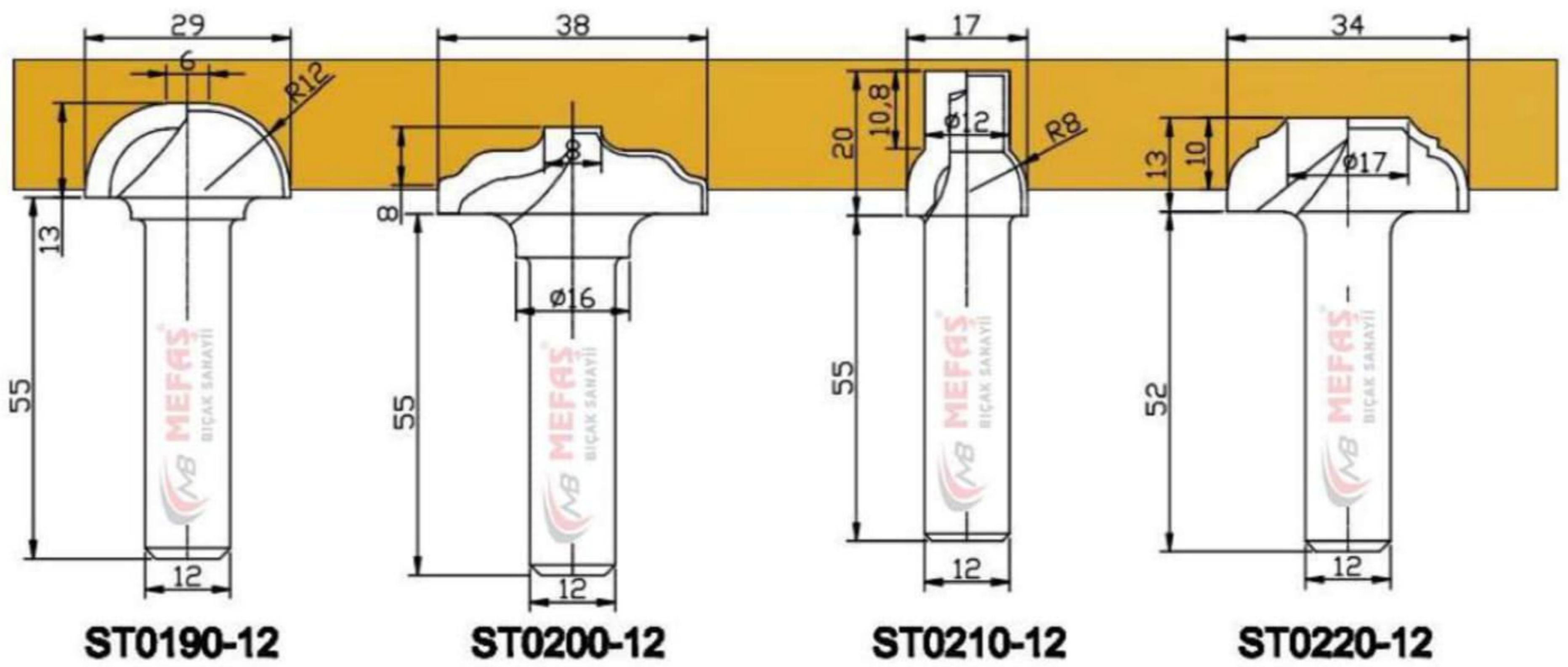
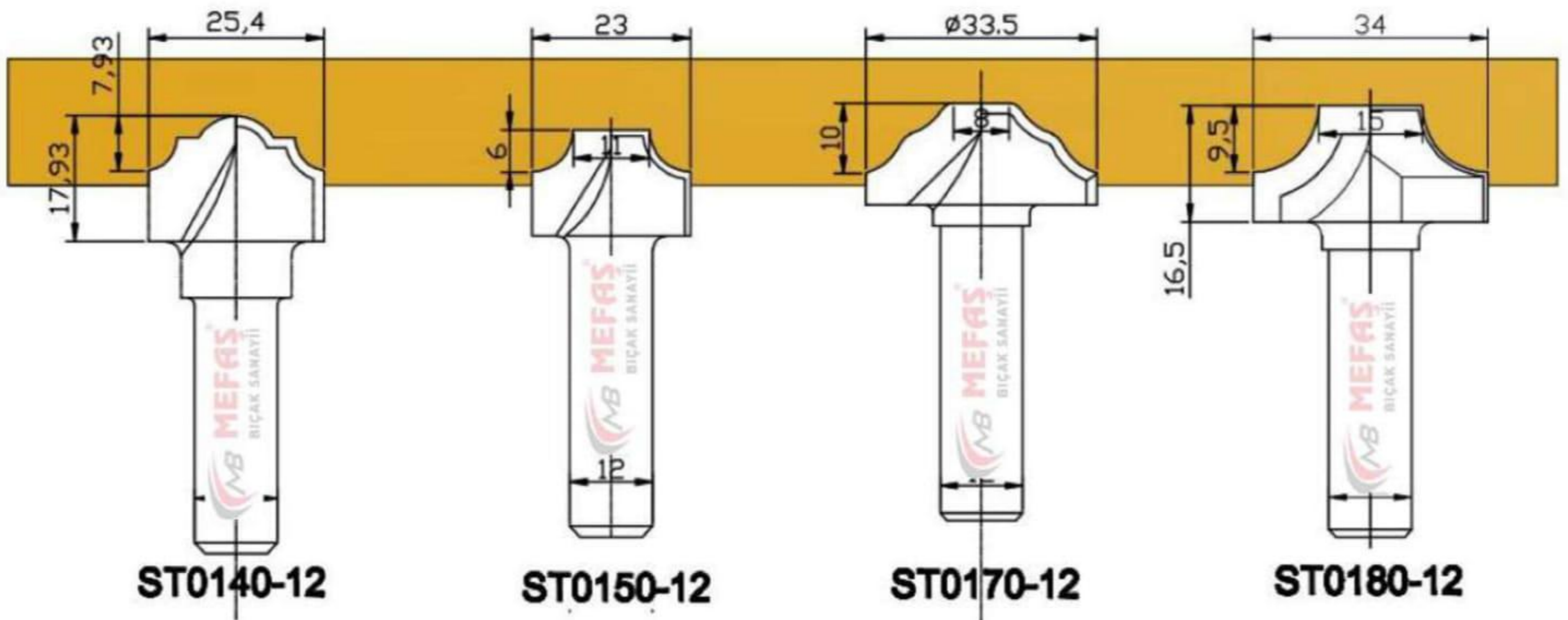
ST1174574-16

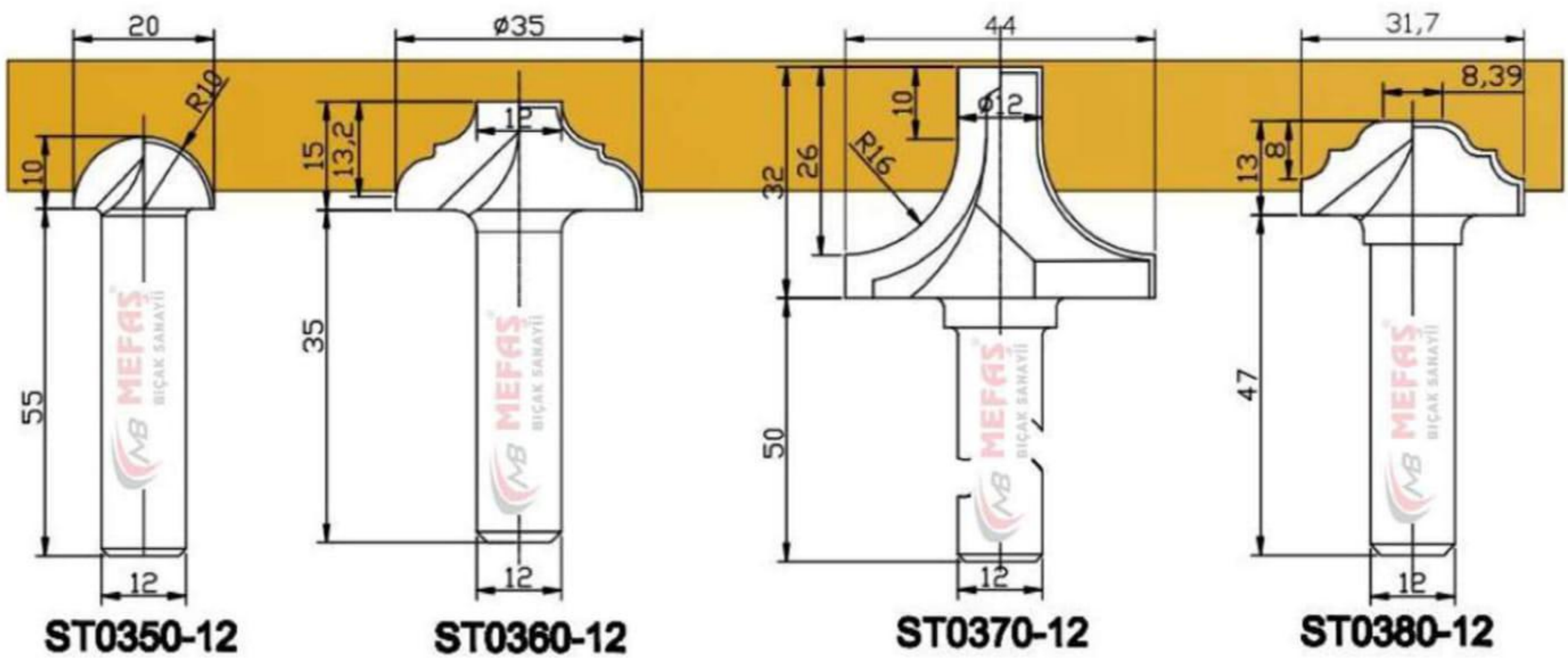
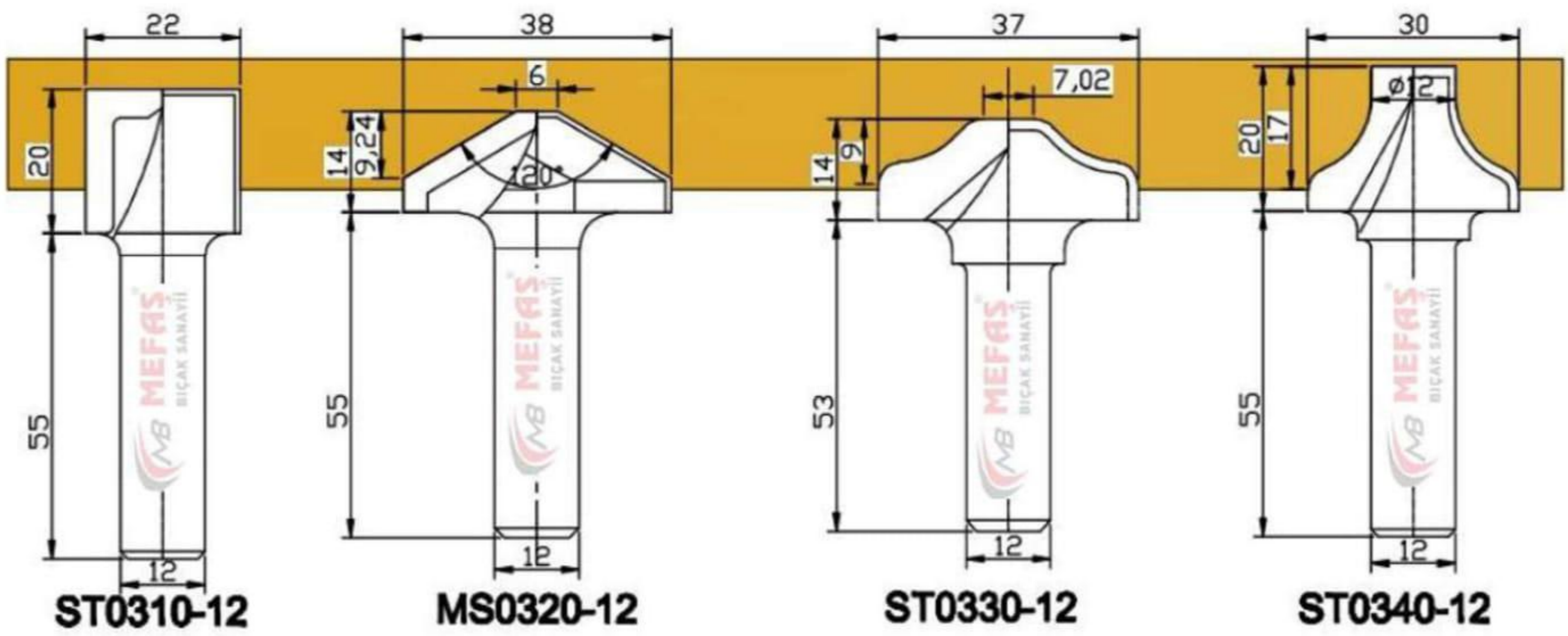
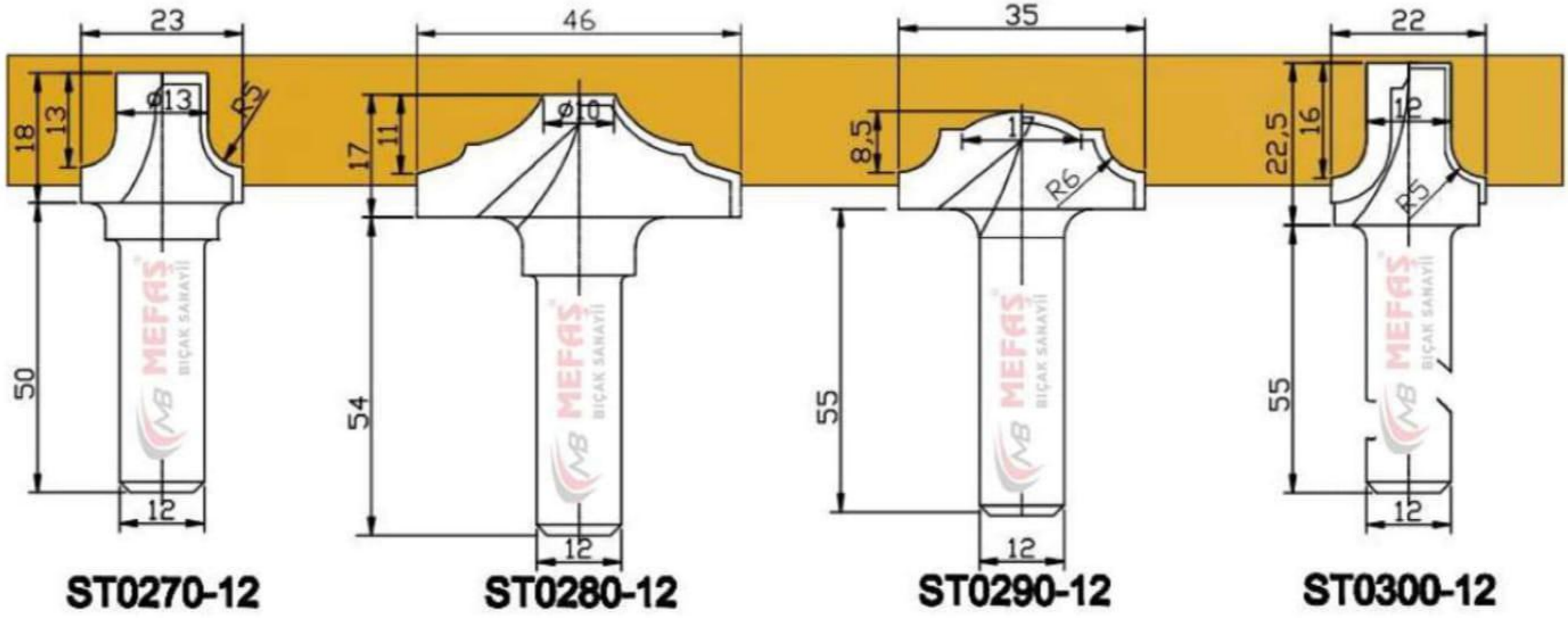
ST 0950-12

ST 0950-12 D38.1 H20.7

ST1/2*40*H25

ST113608

ST 0951-12

ST 0952-12

ST 0954-12

ST057035



1/2*53*H20.14-27







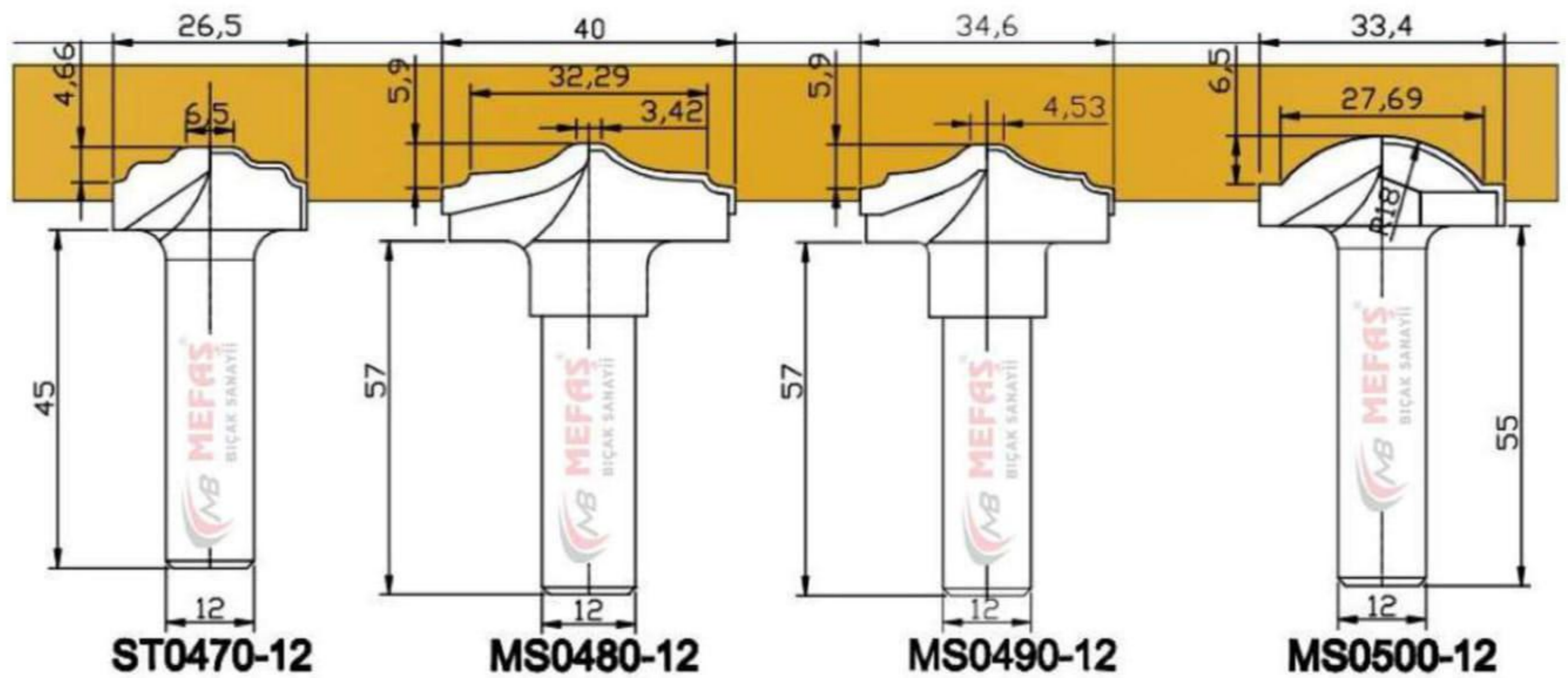
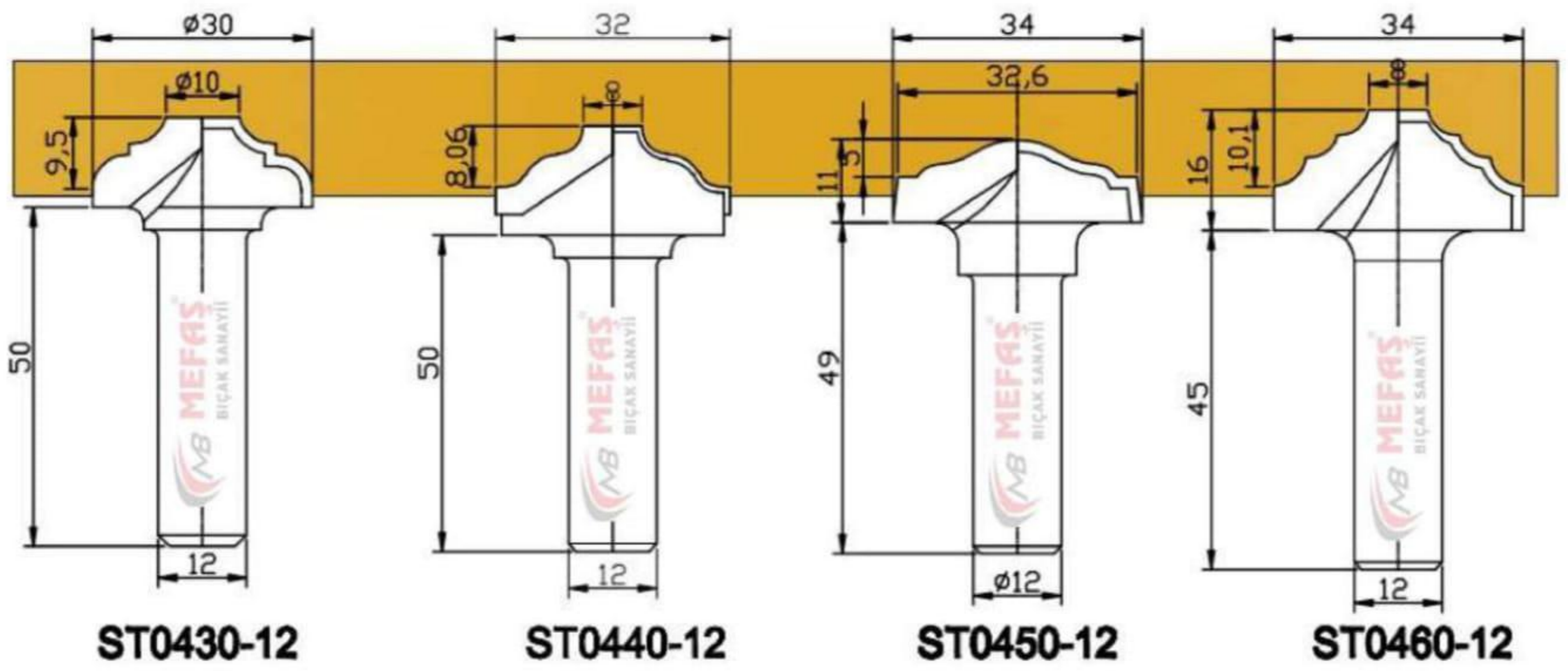
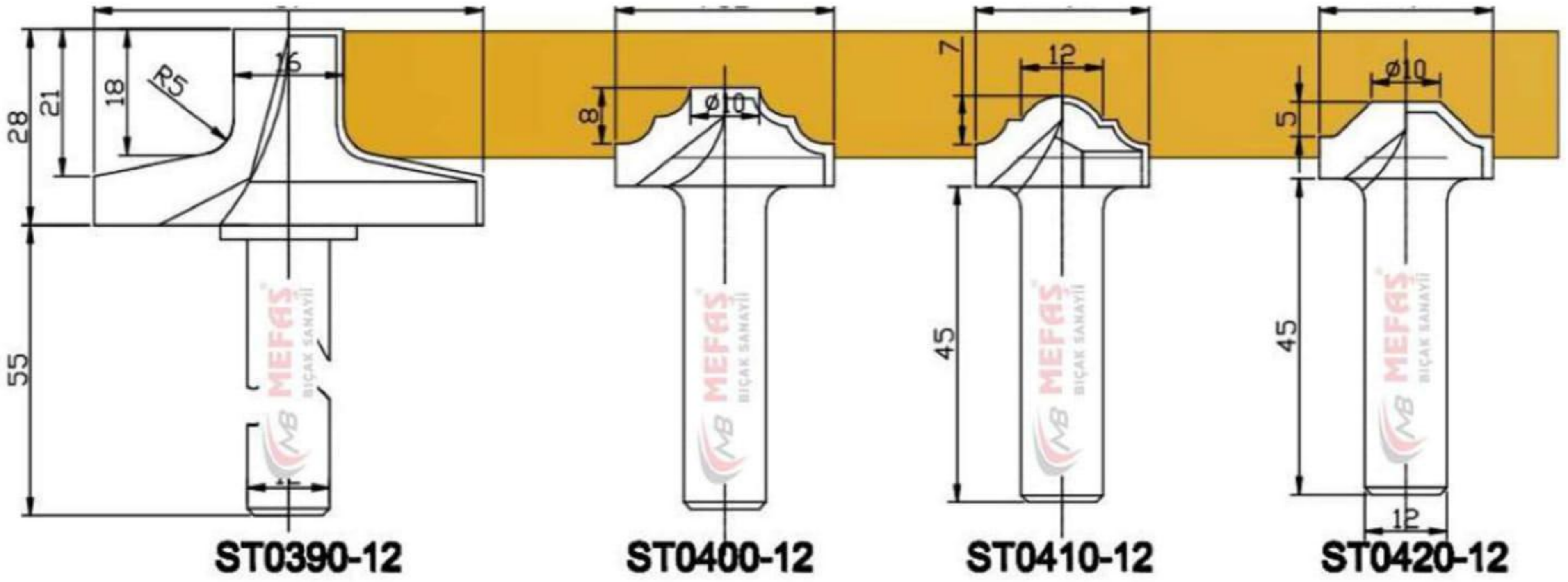

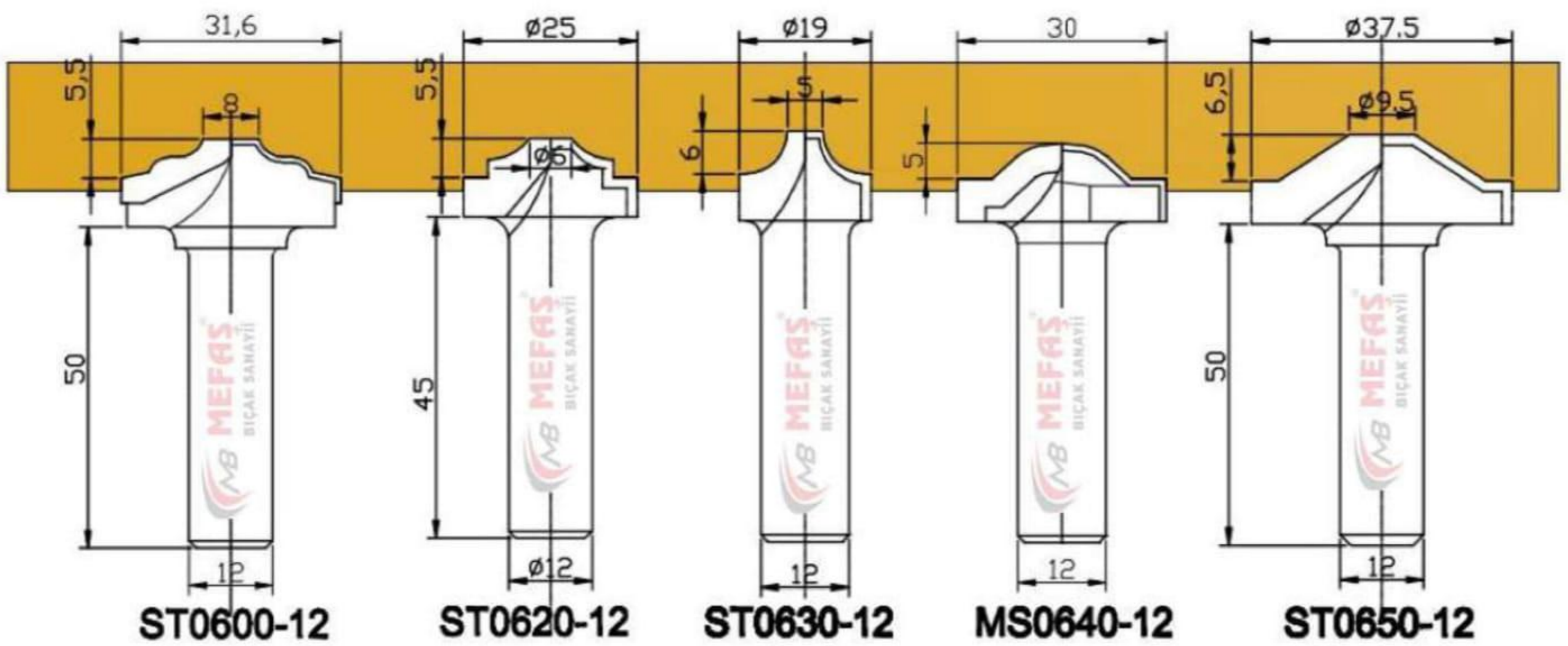
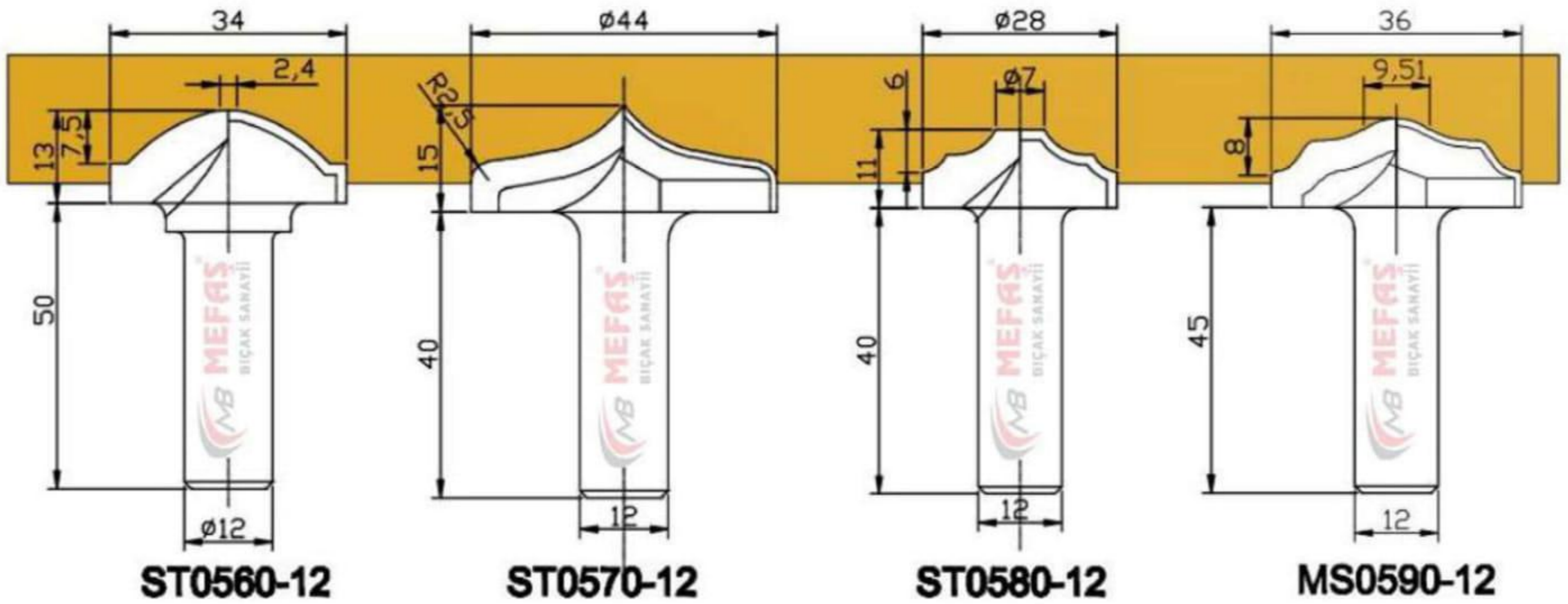
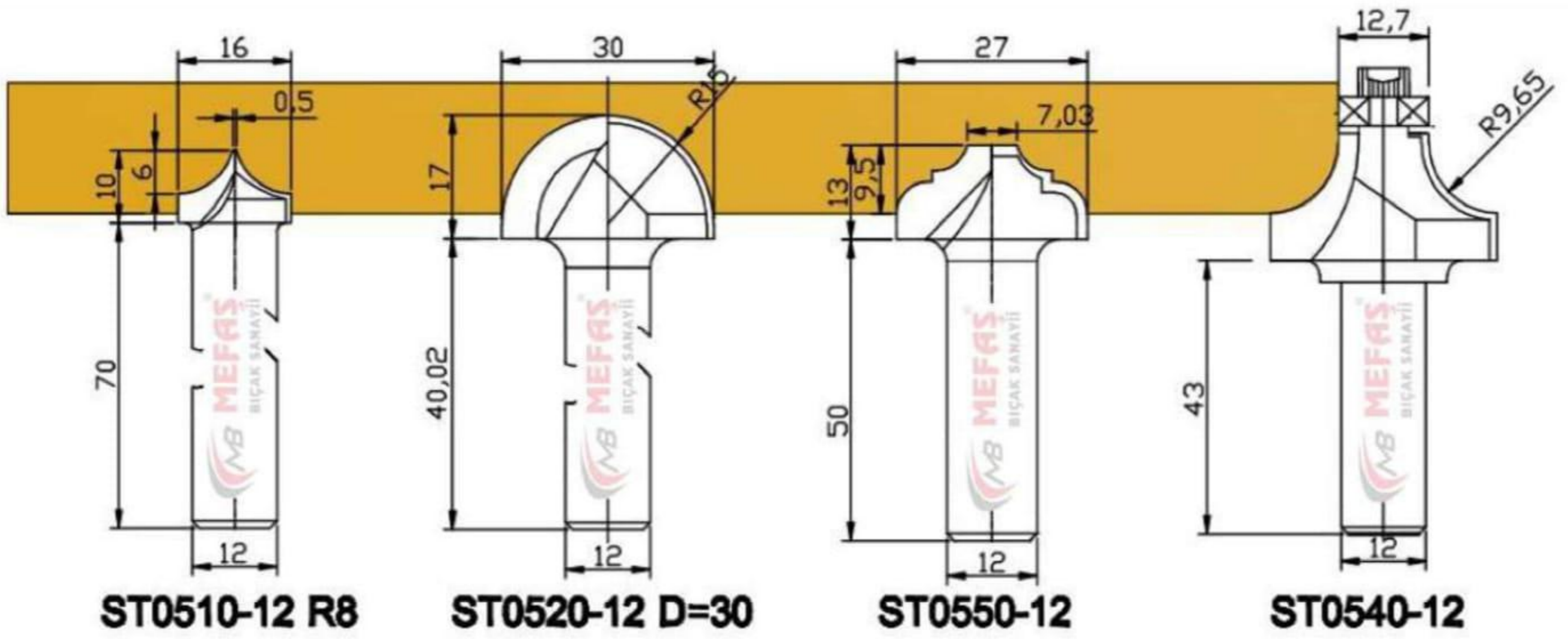

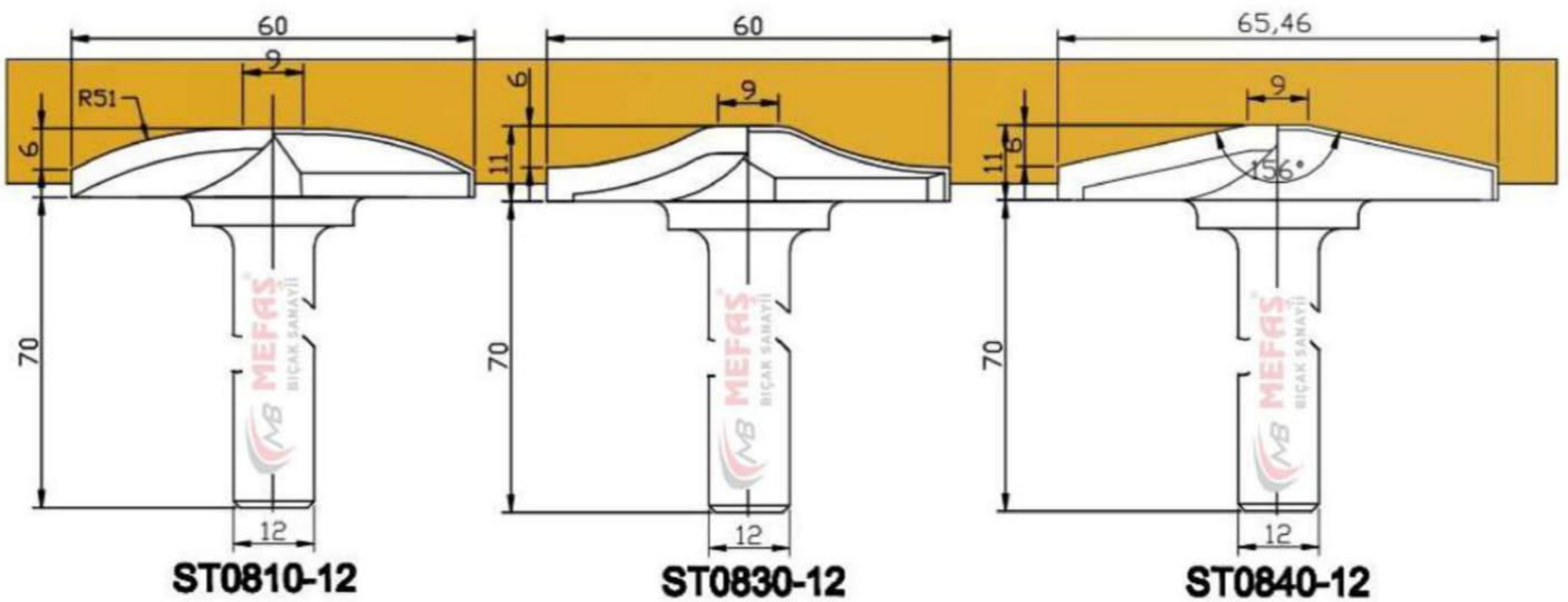
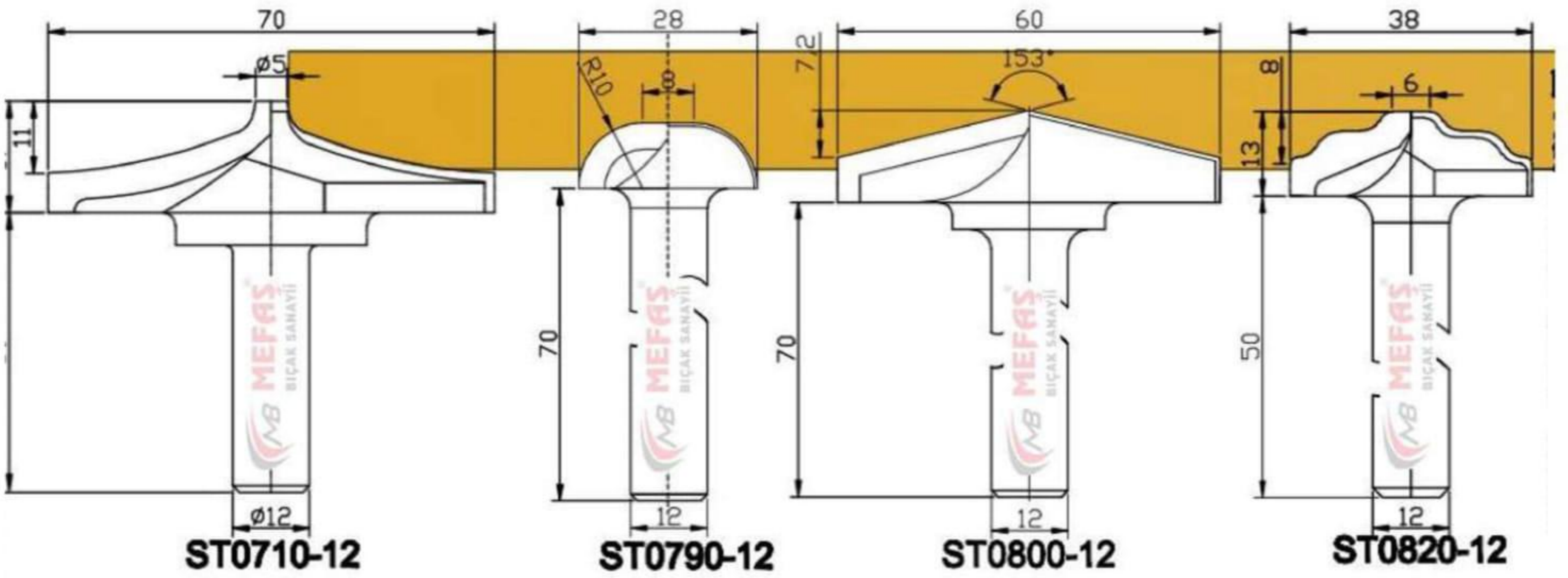
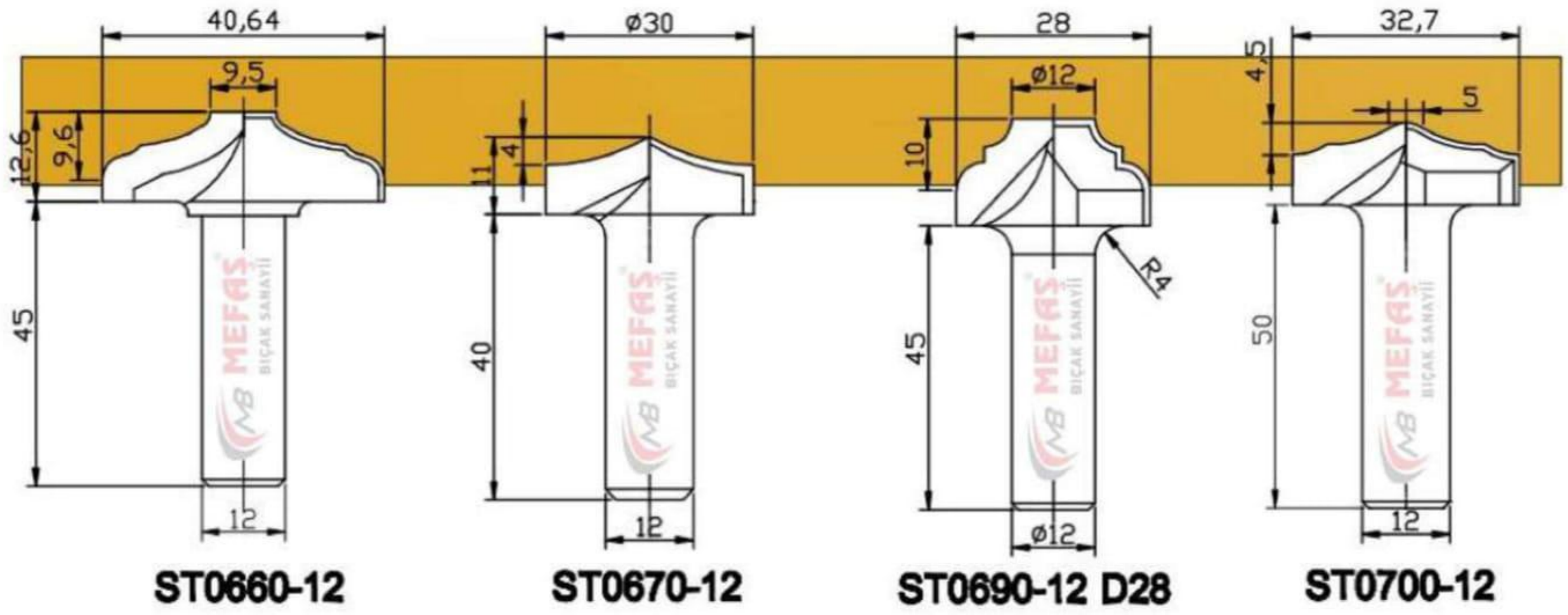

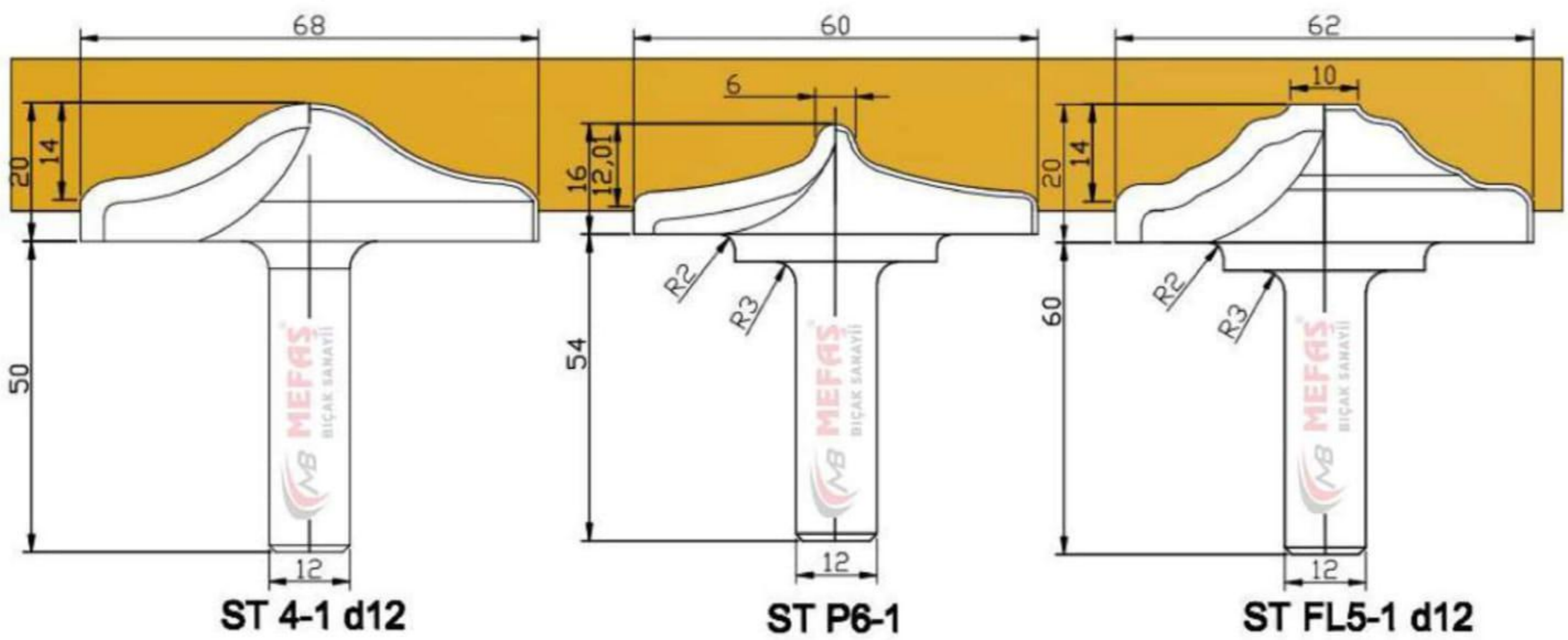
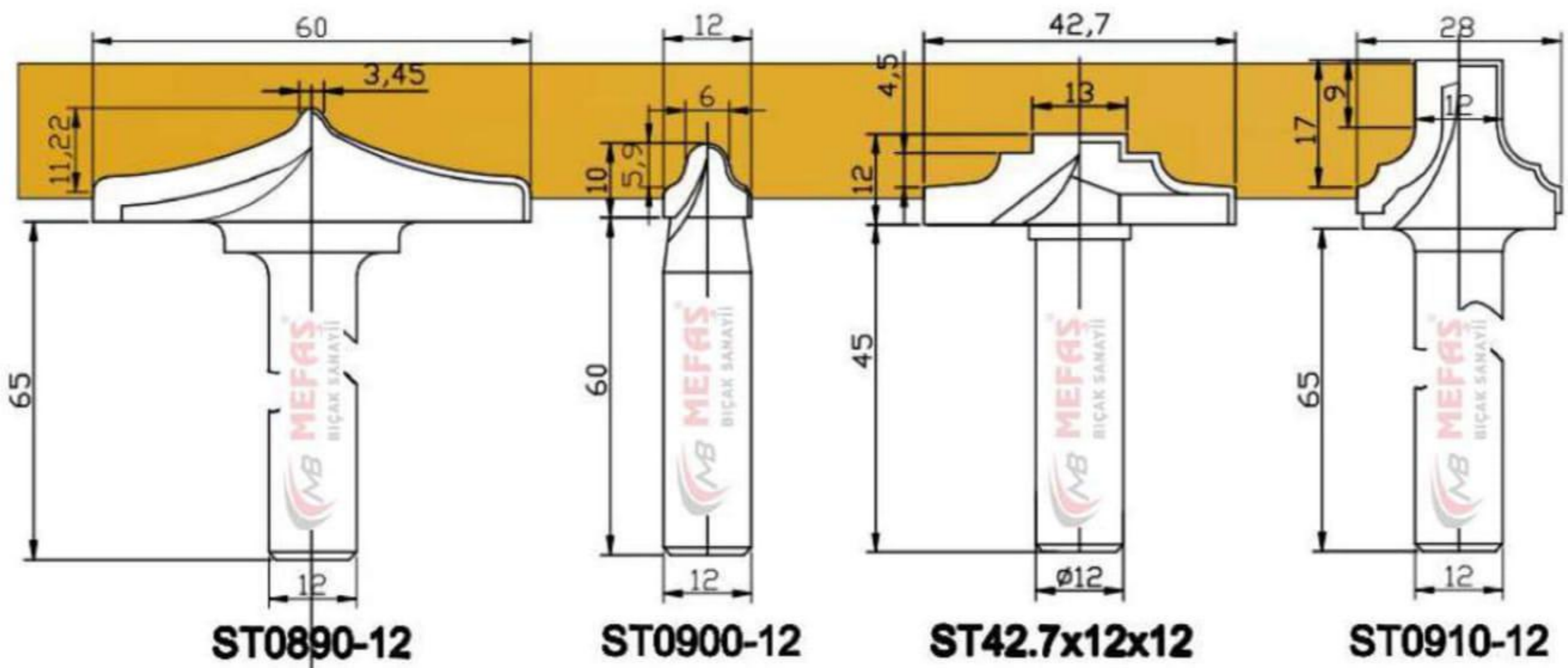
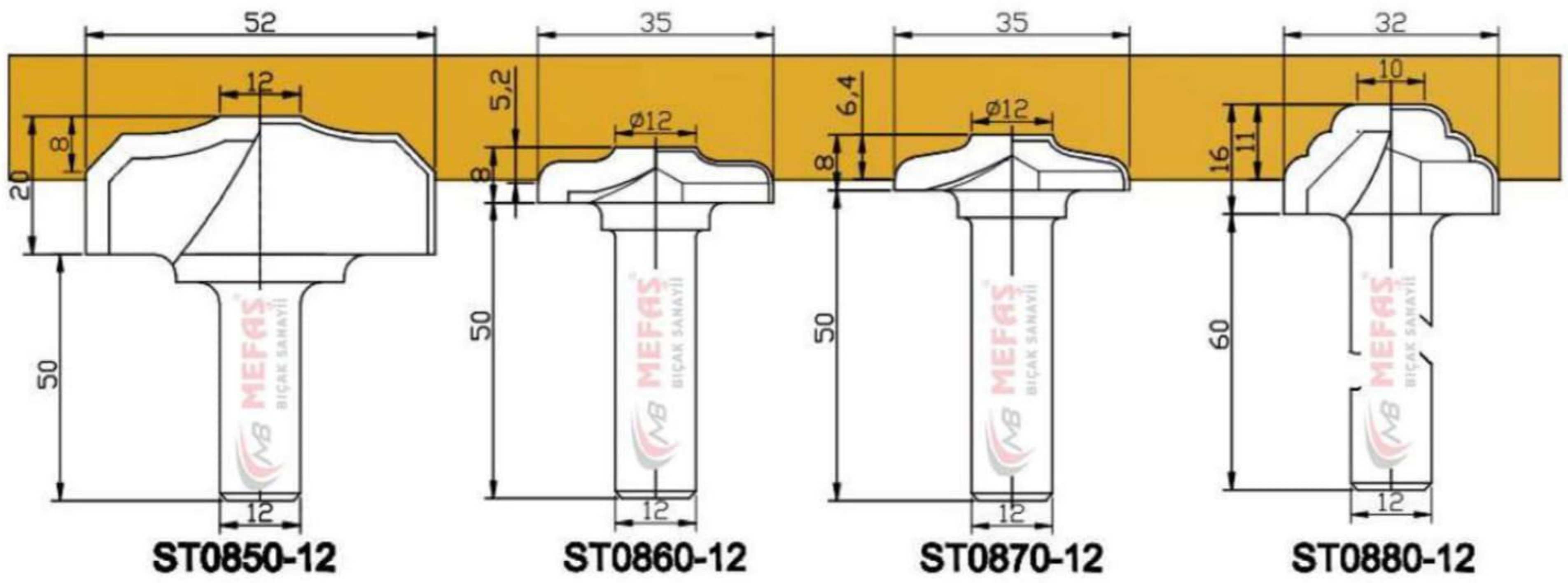

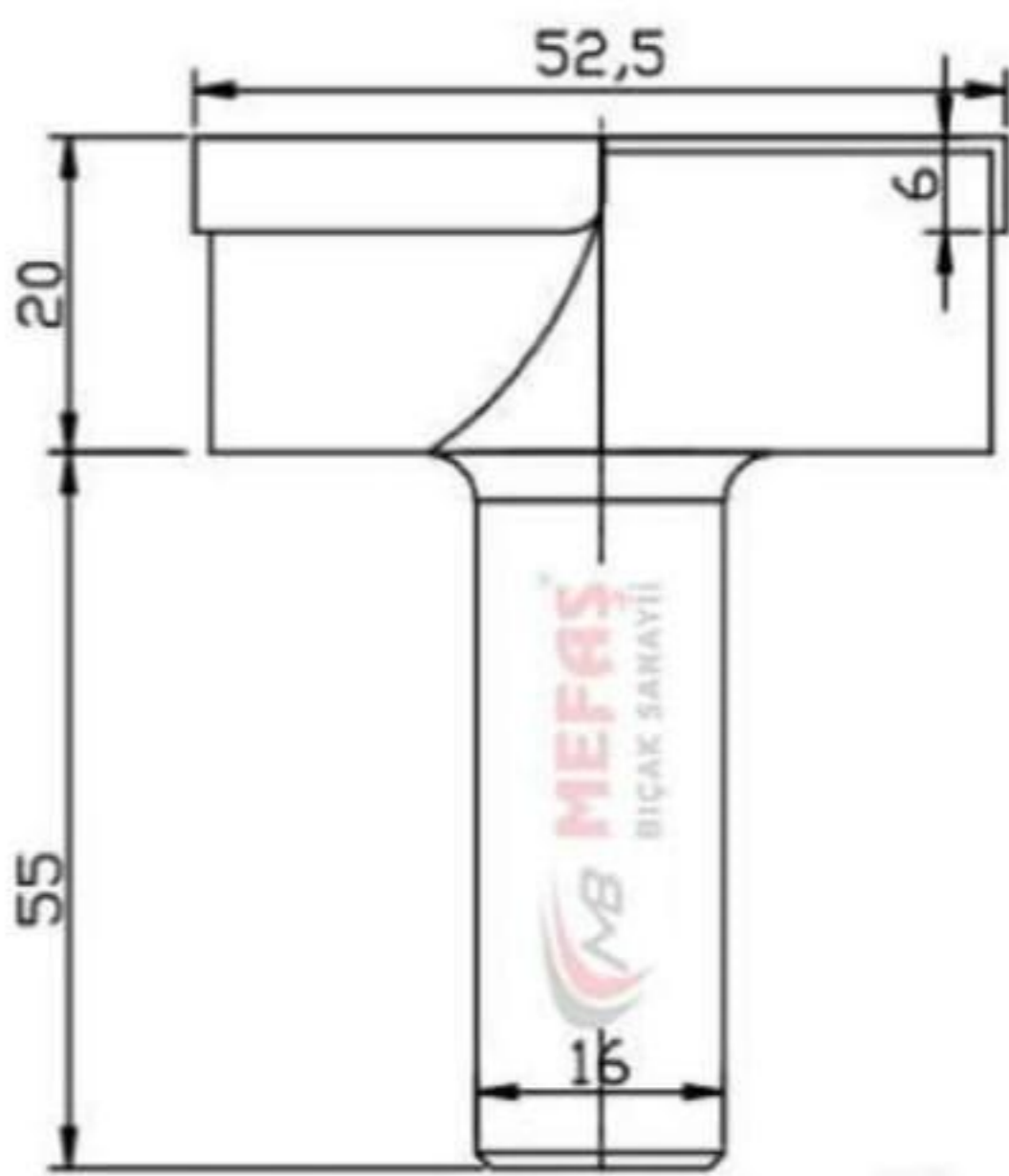

Botom Cleaning Bit
d16xD52.5xH6x2Z

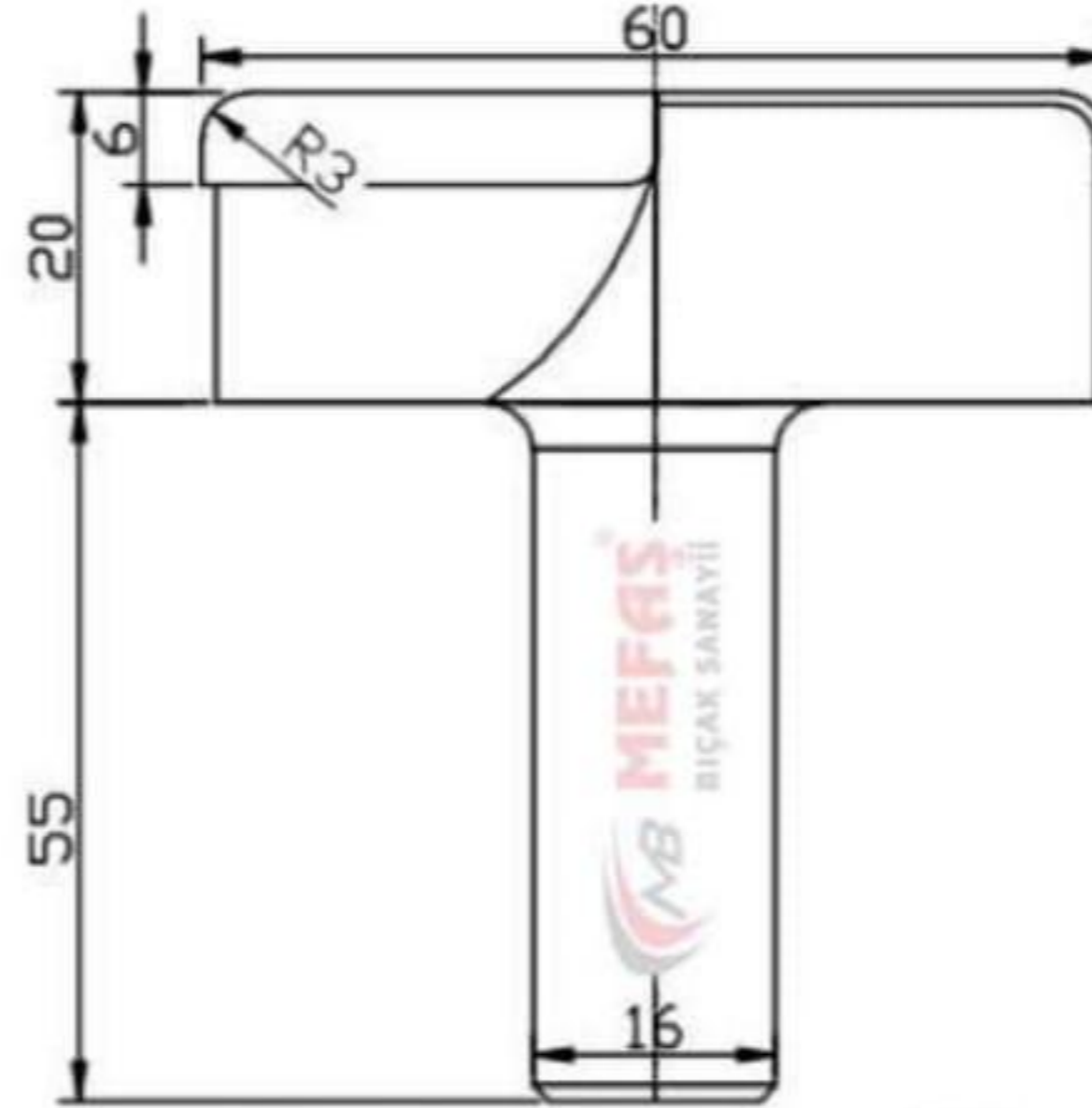

Botom Cleaning Bit
d16xD60xH6xR3x2Z

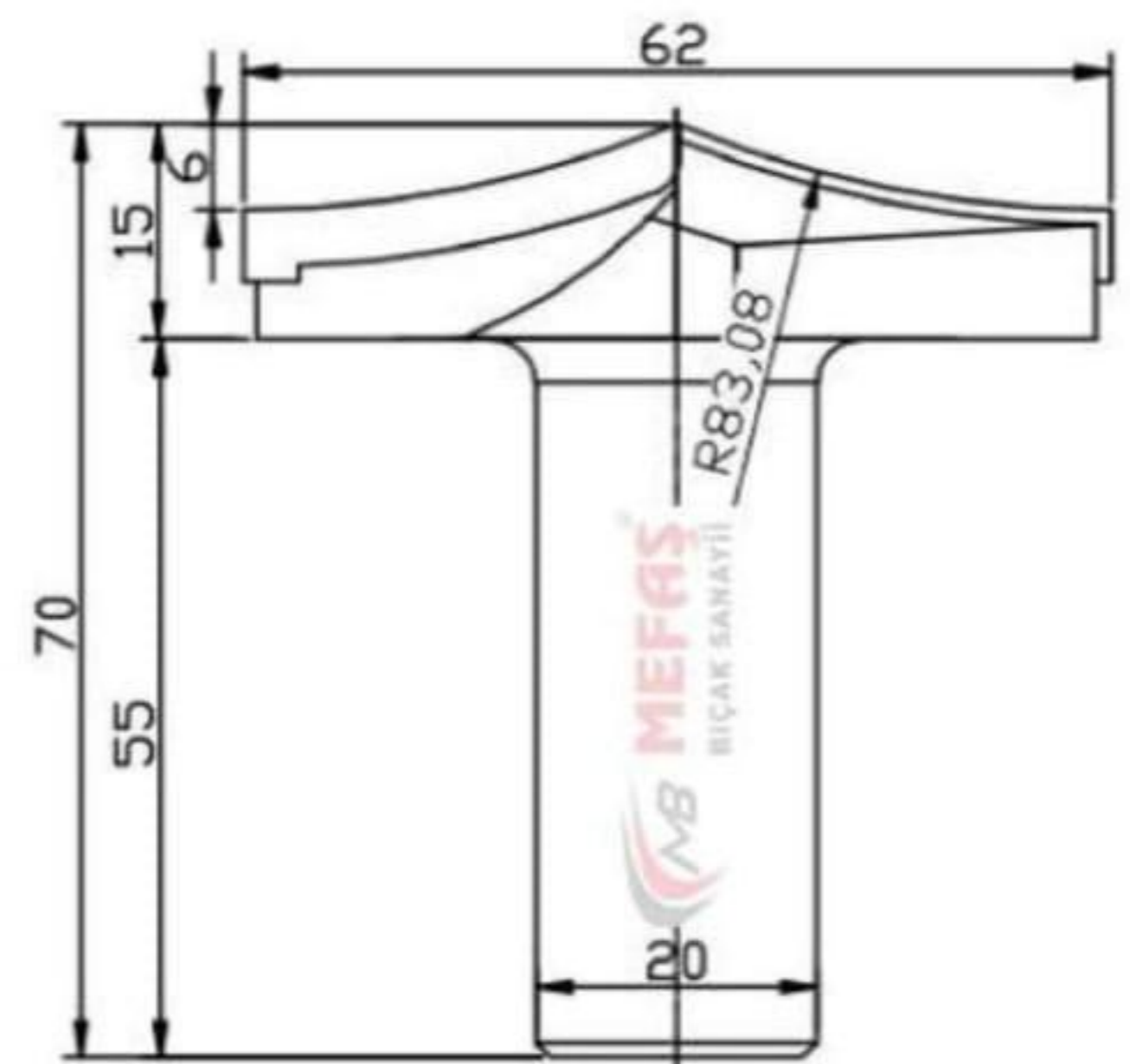

ST192019
d20xD62xH12x2Z R83.08

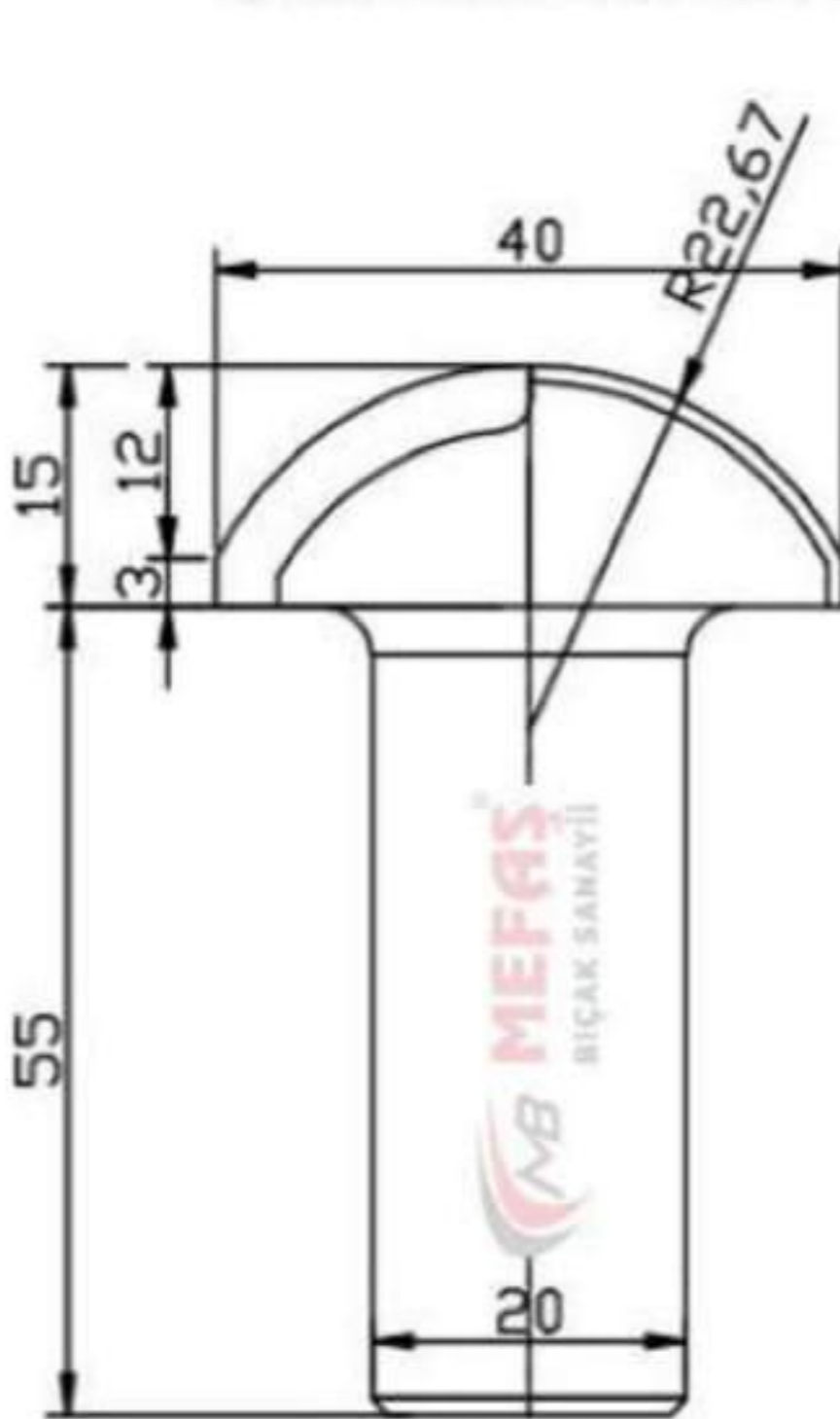

ST192022
d20xD40xH15 R22.67

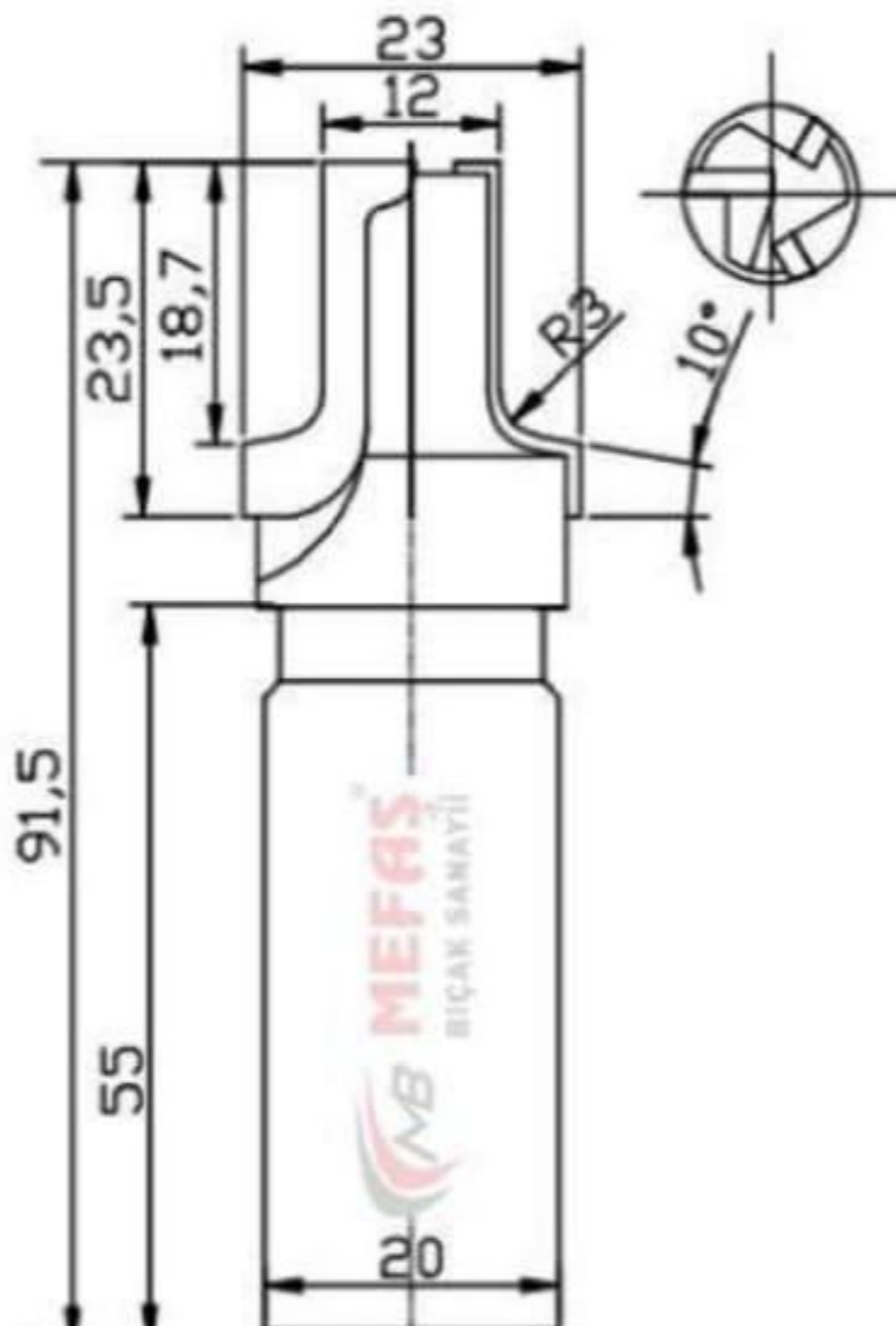

ST192008
d20xD23xH18.7xR3-3T-3°

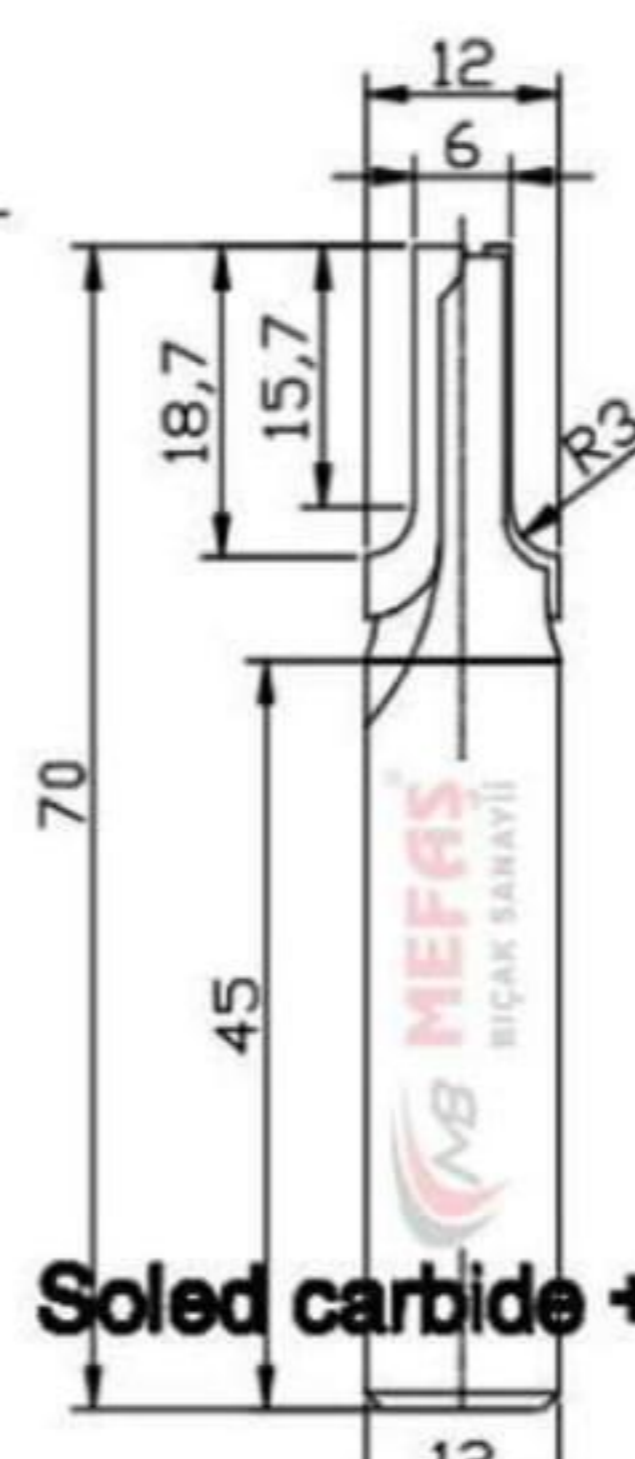

Soled carbide +PCD

ST192018
D6*18.7*R3*70L*D12-2Z

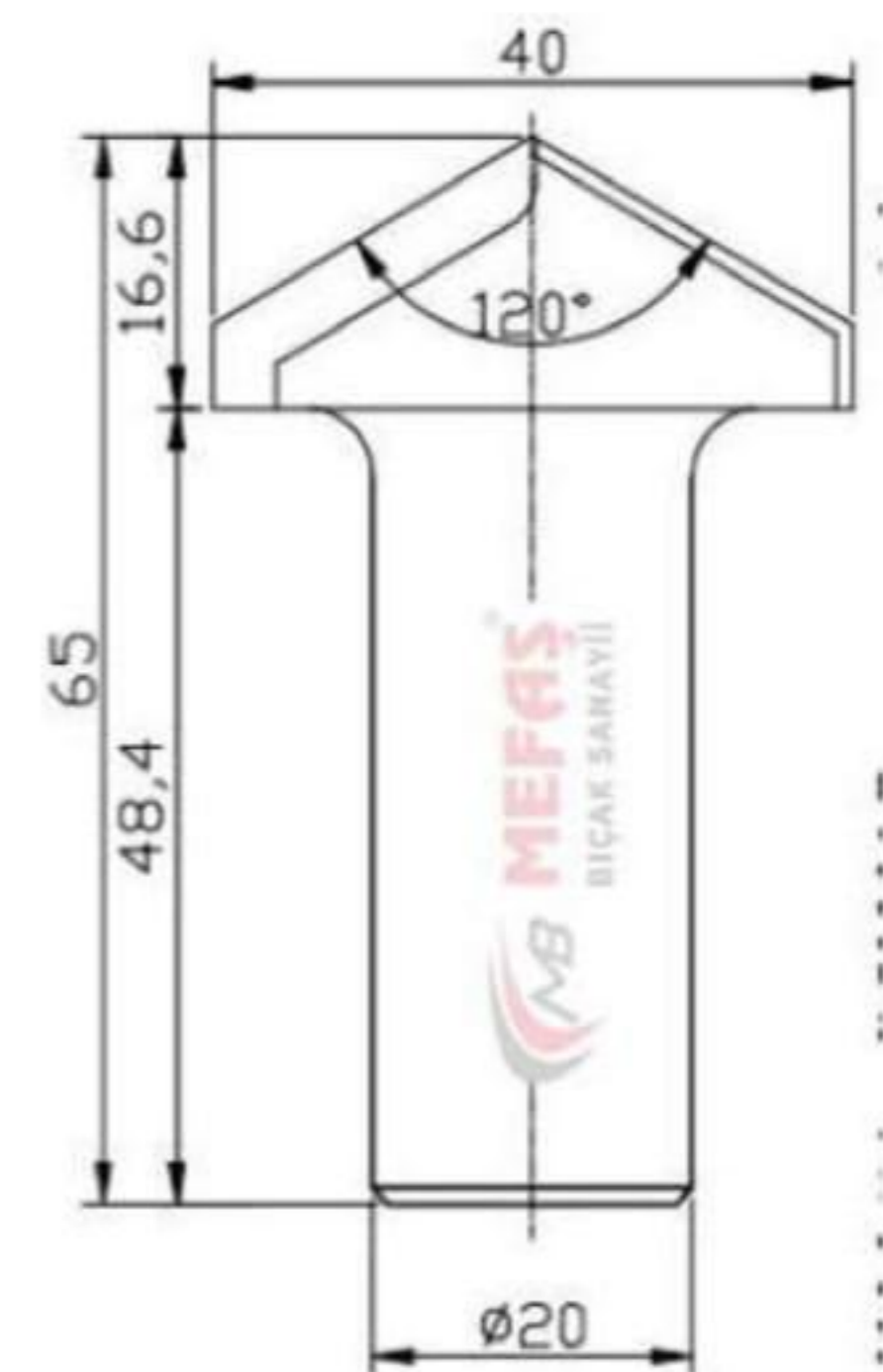

20*D40*H16.6*V120

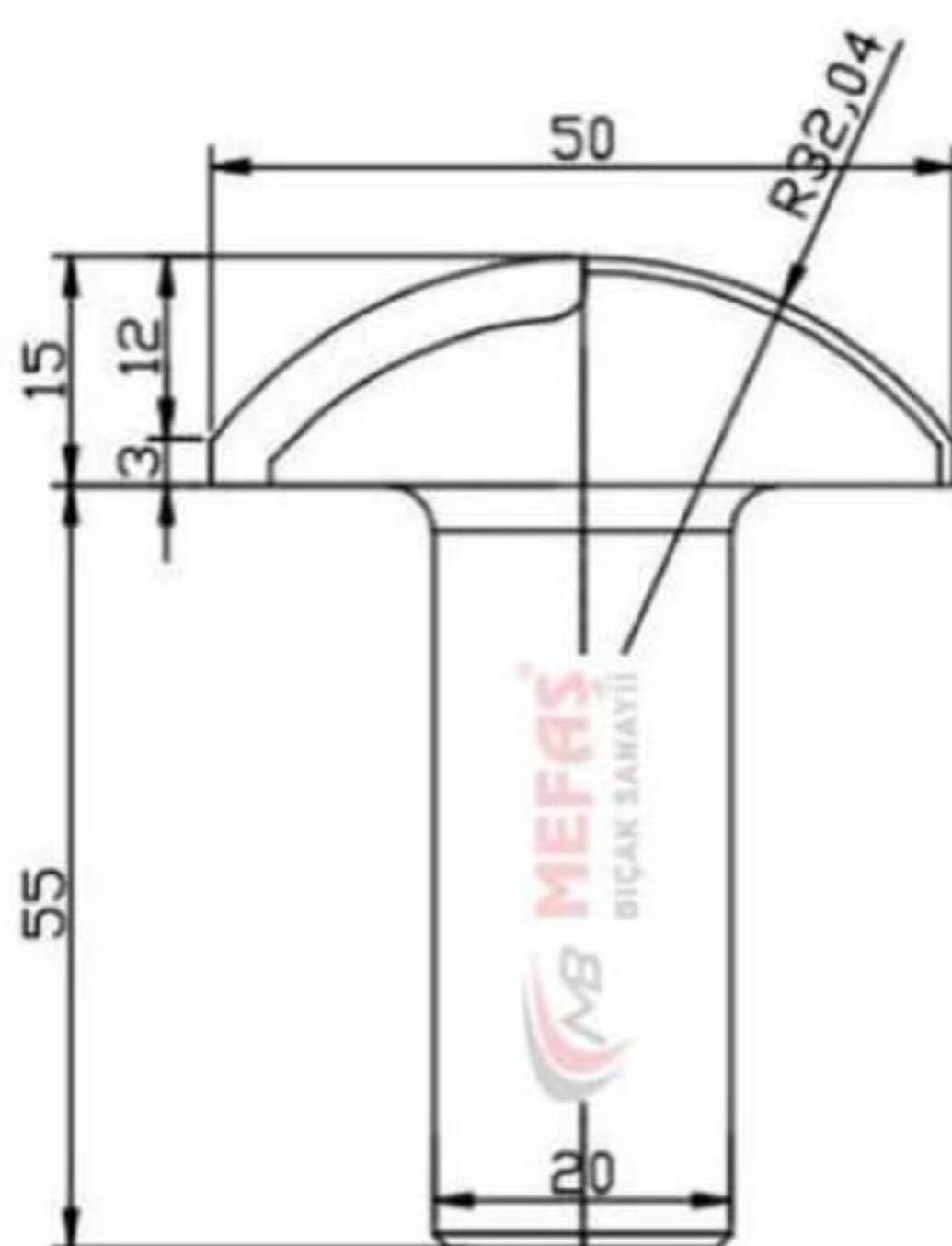

ST192020
d20xD50xH15 R32.04

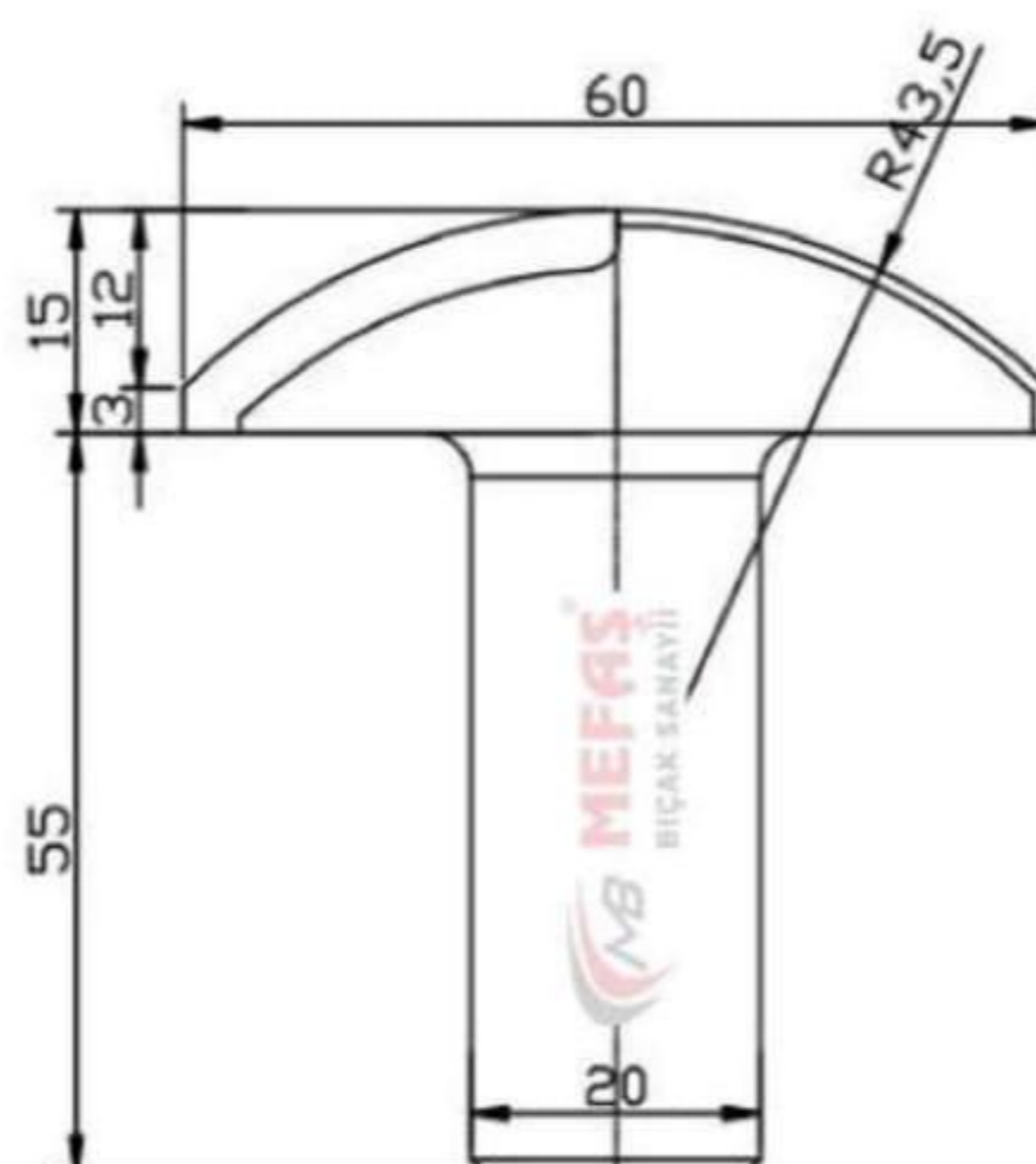

ST192021
d20xD60xH15 R43.5

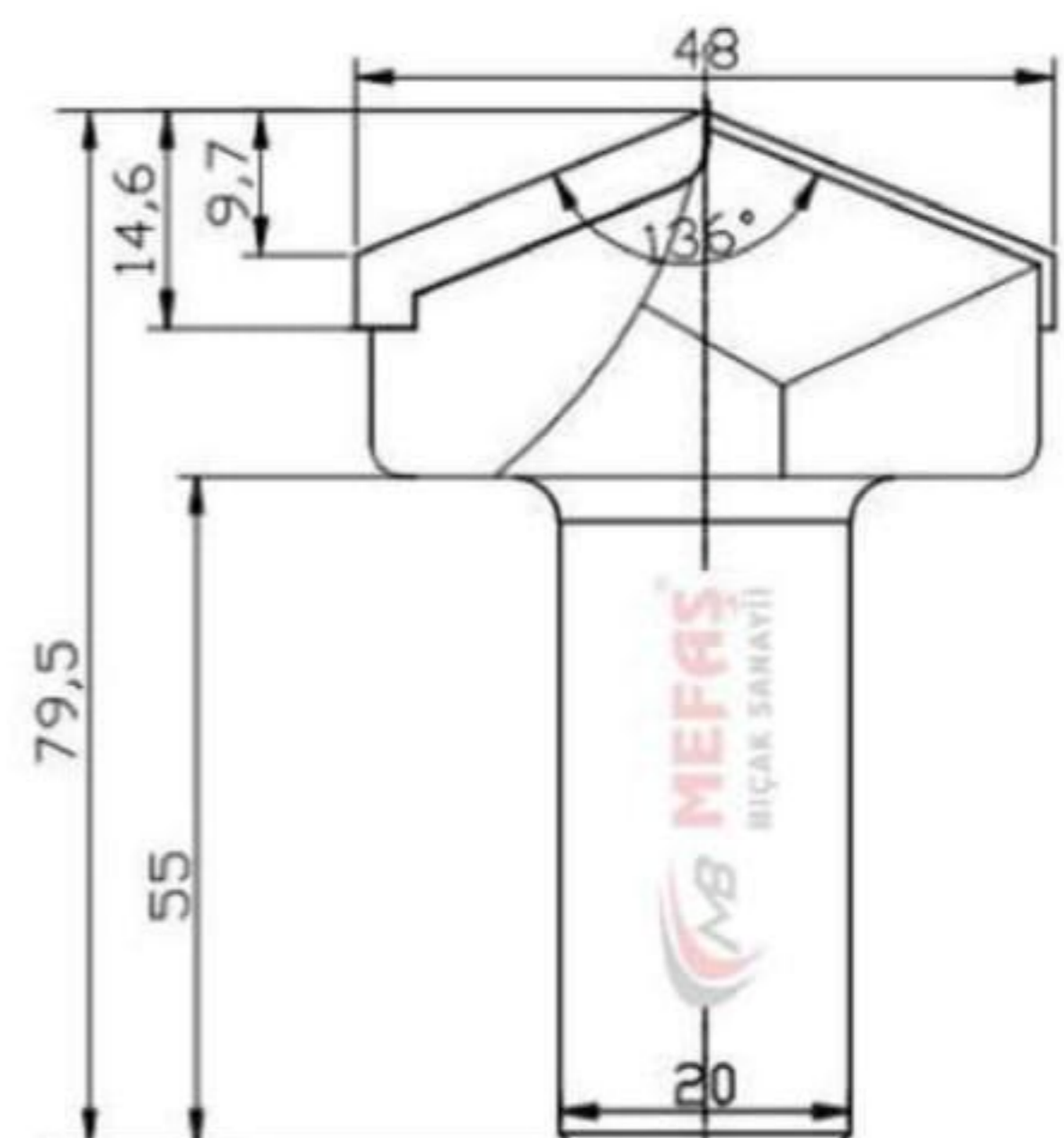

20*D48*H14.6*V136

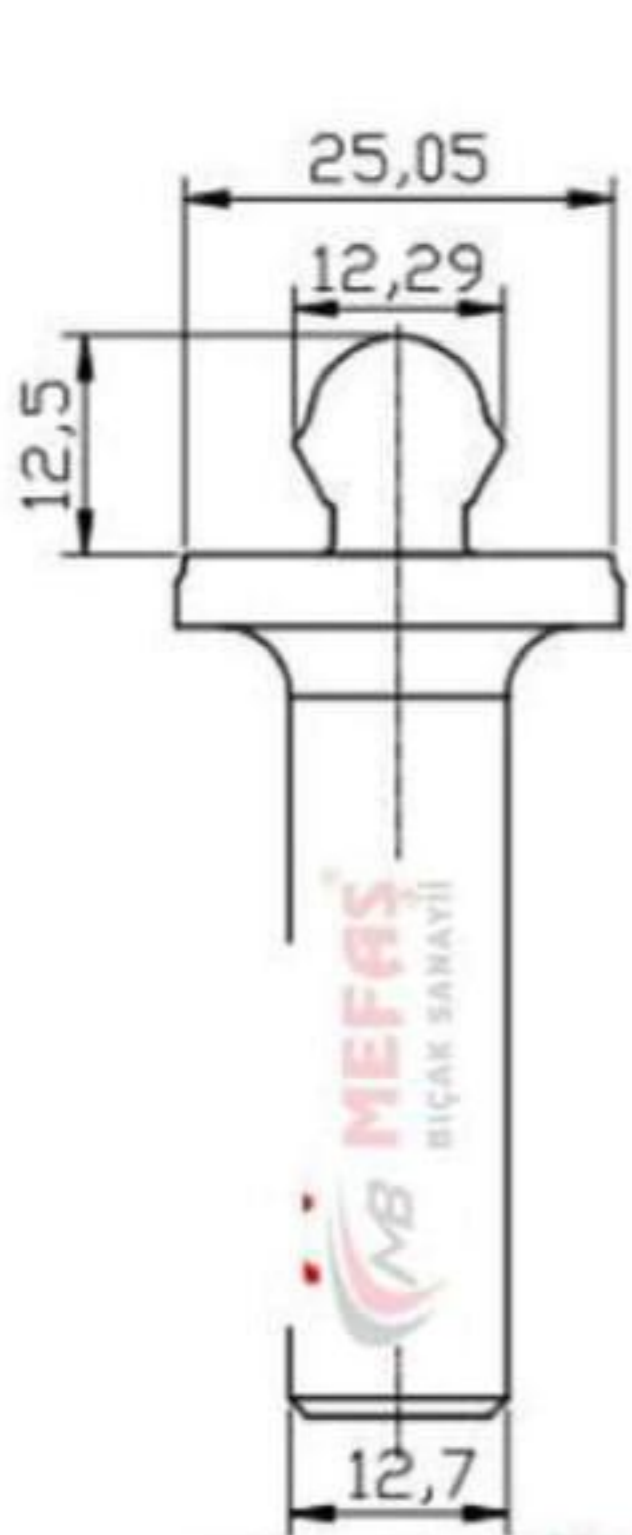
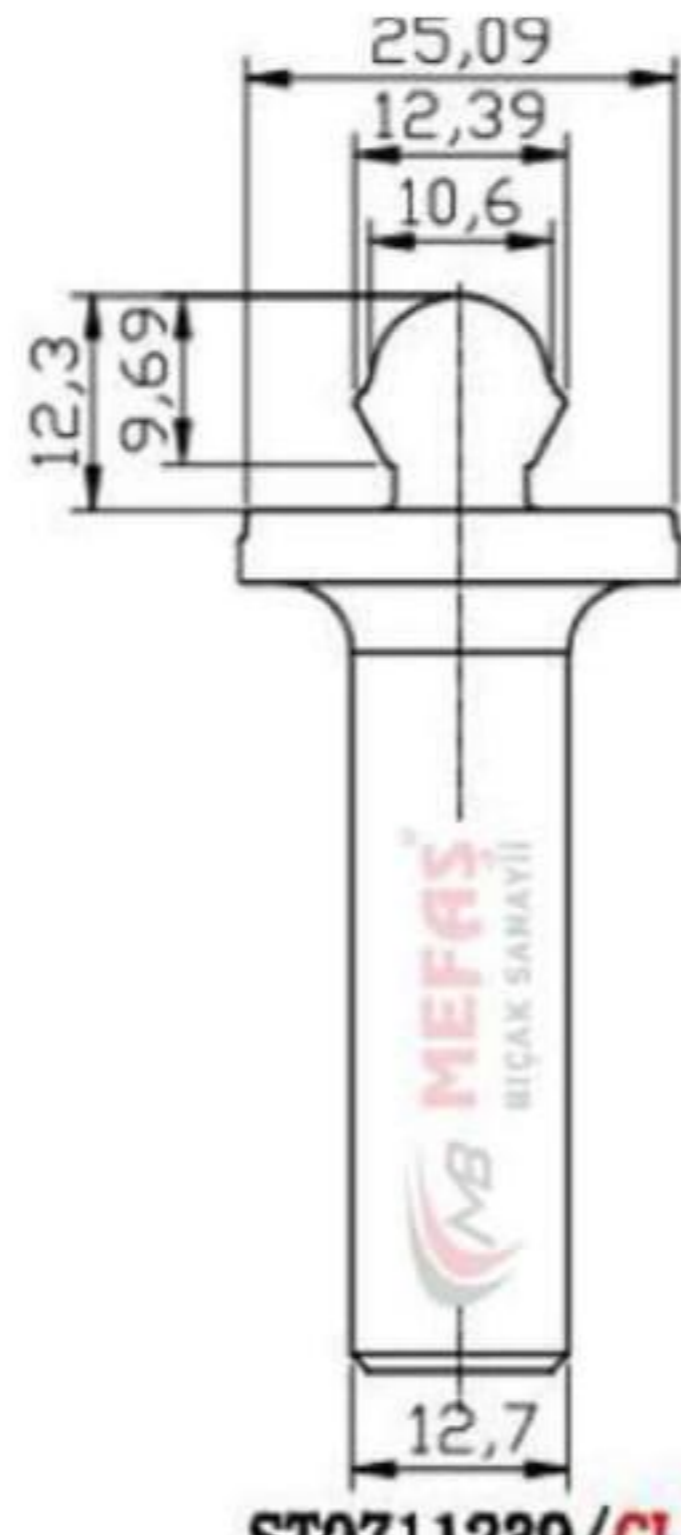
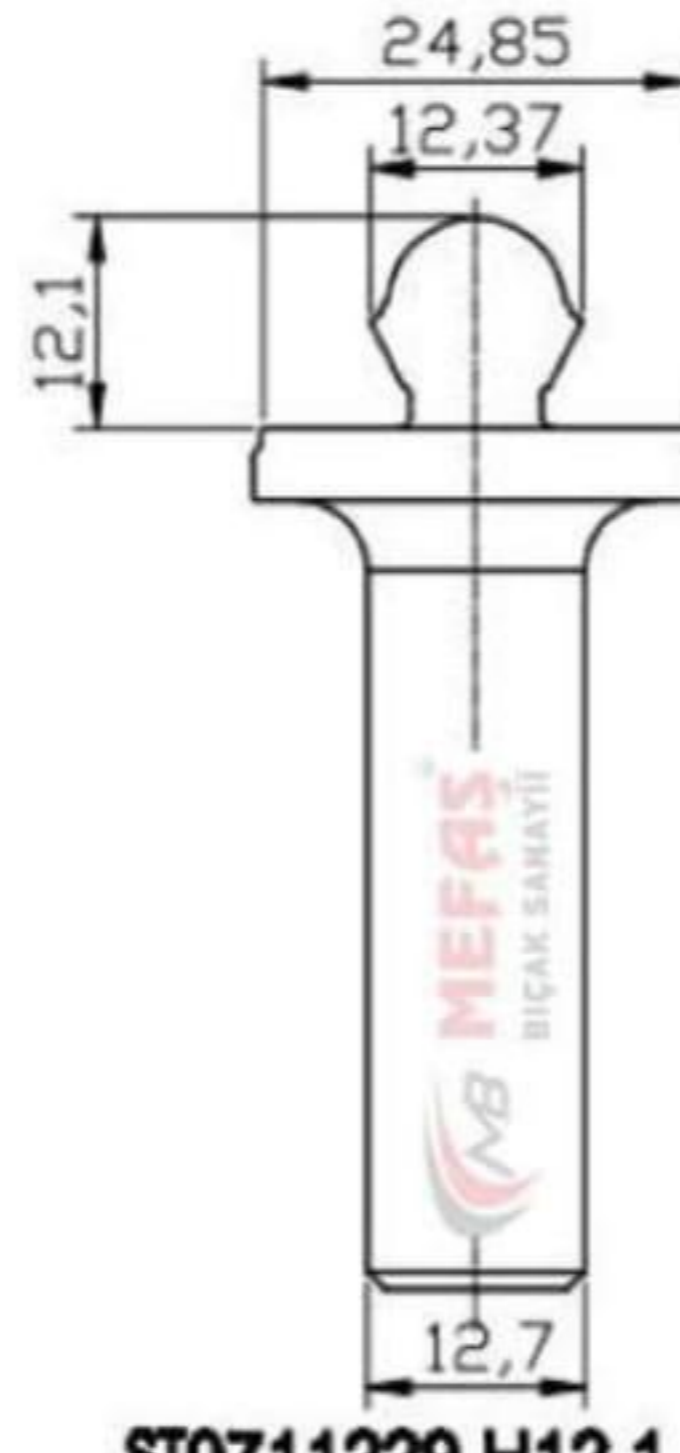
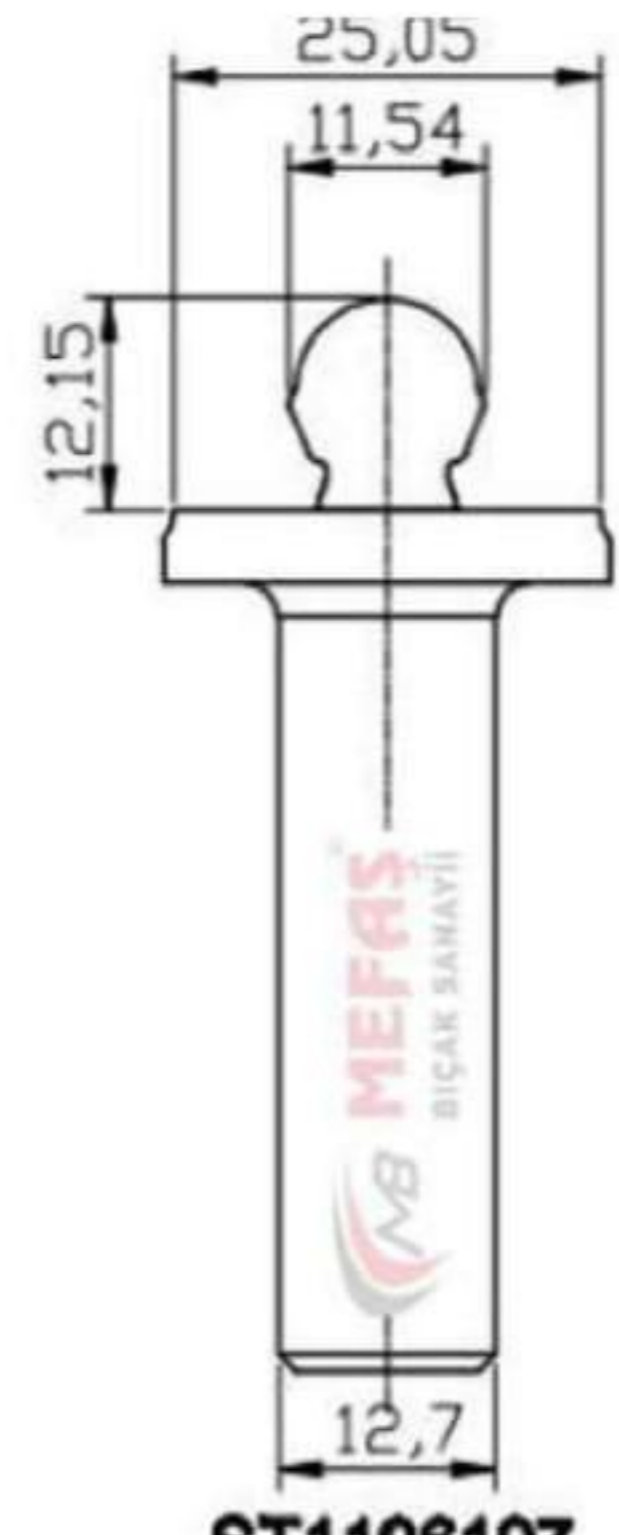
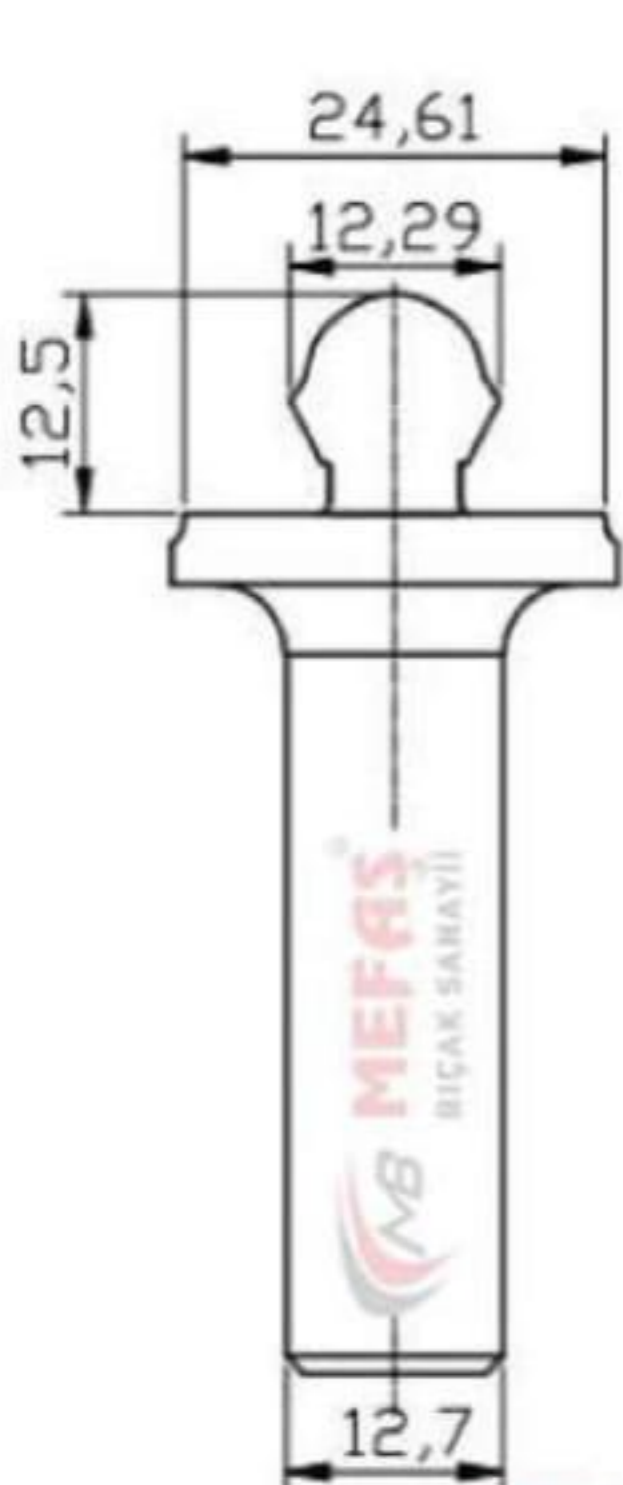
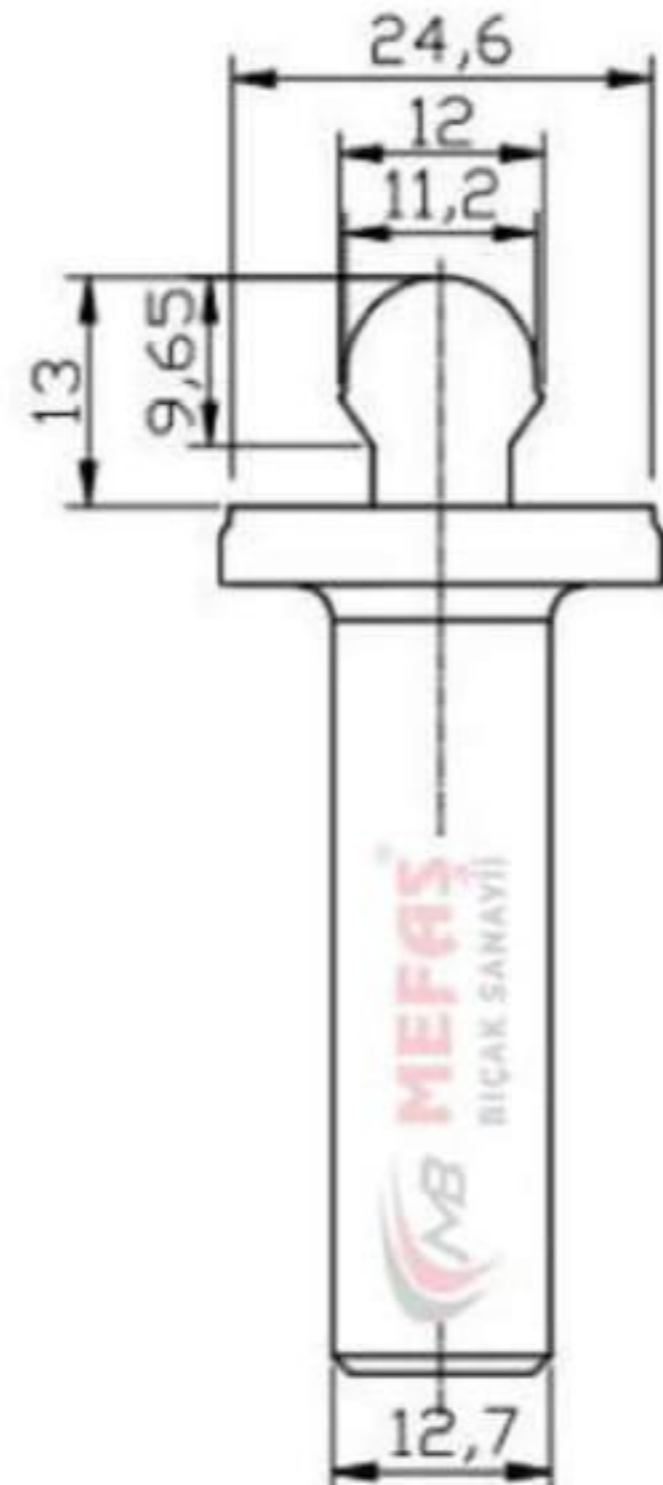
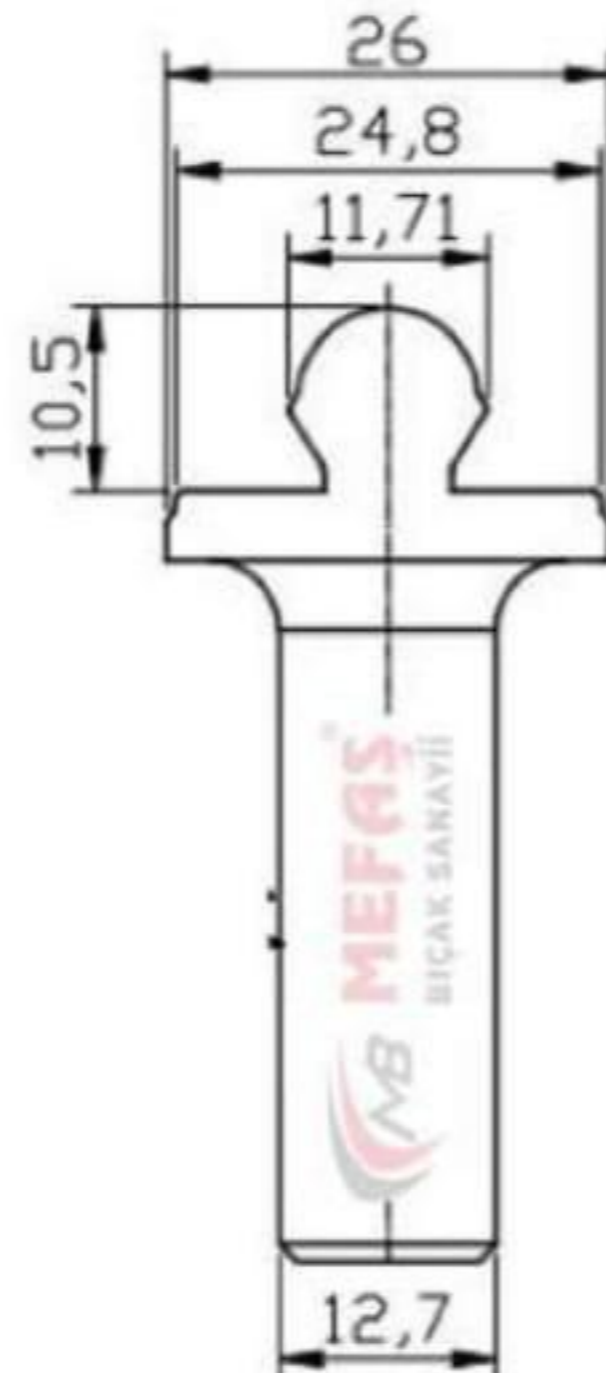

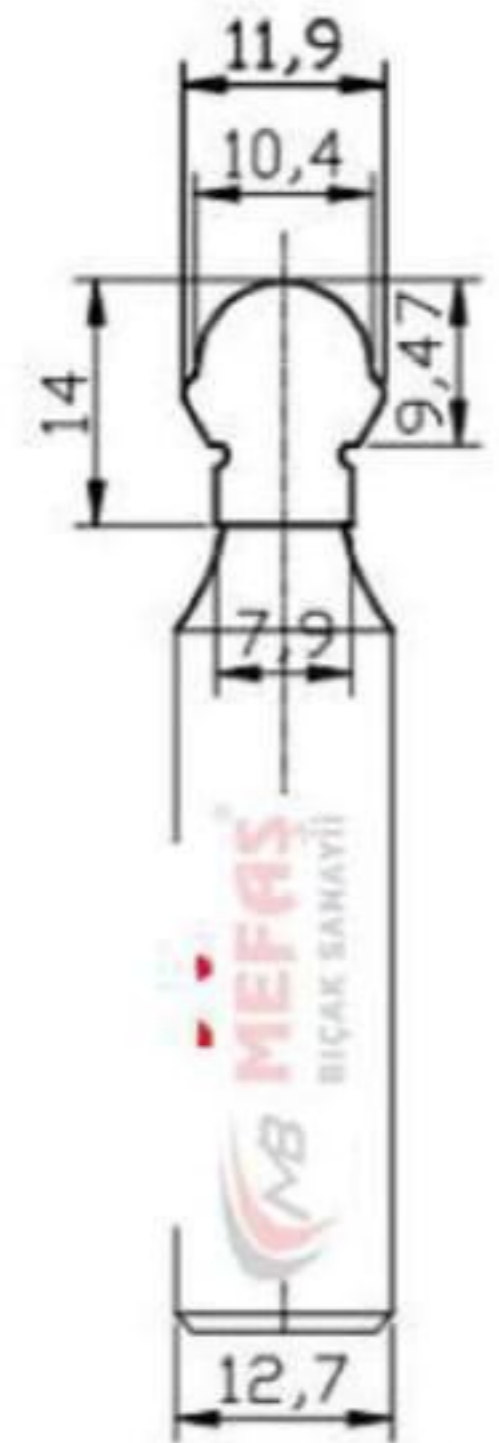
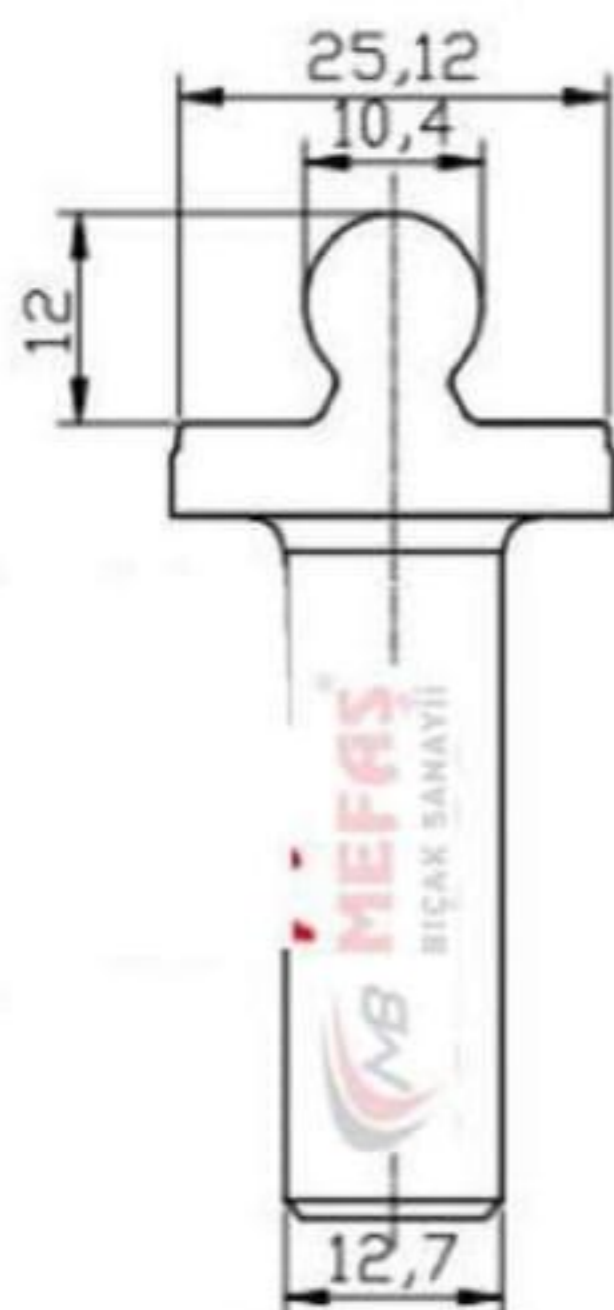
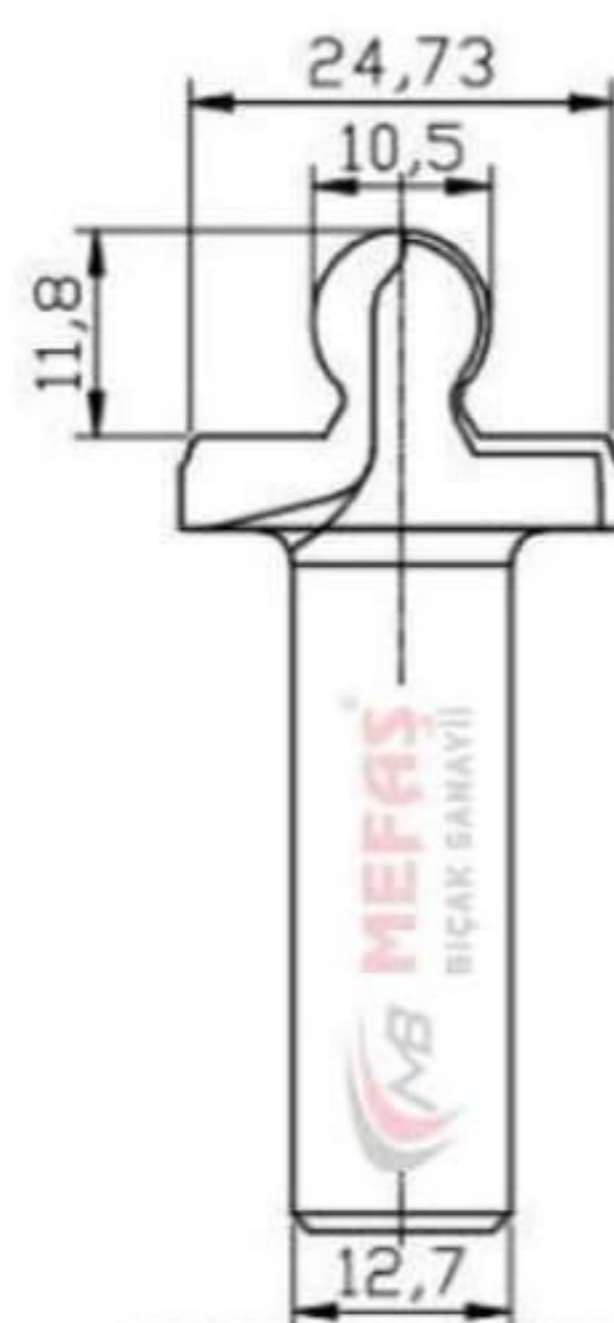
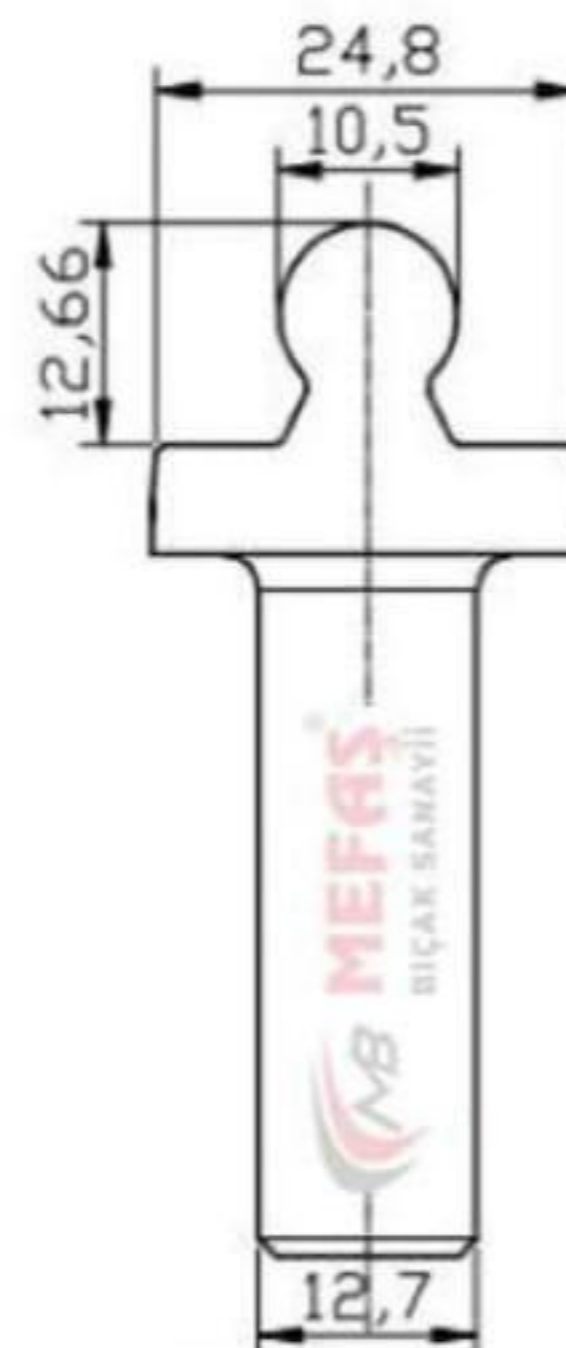
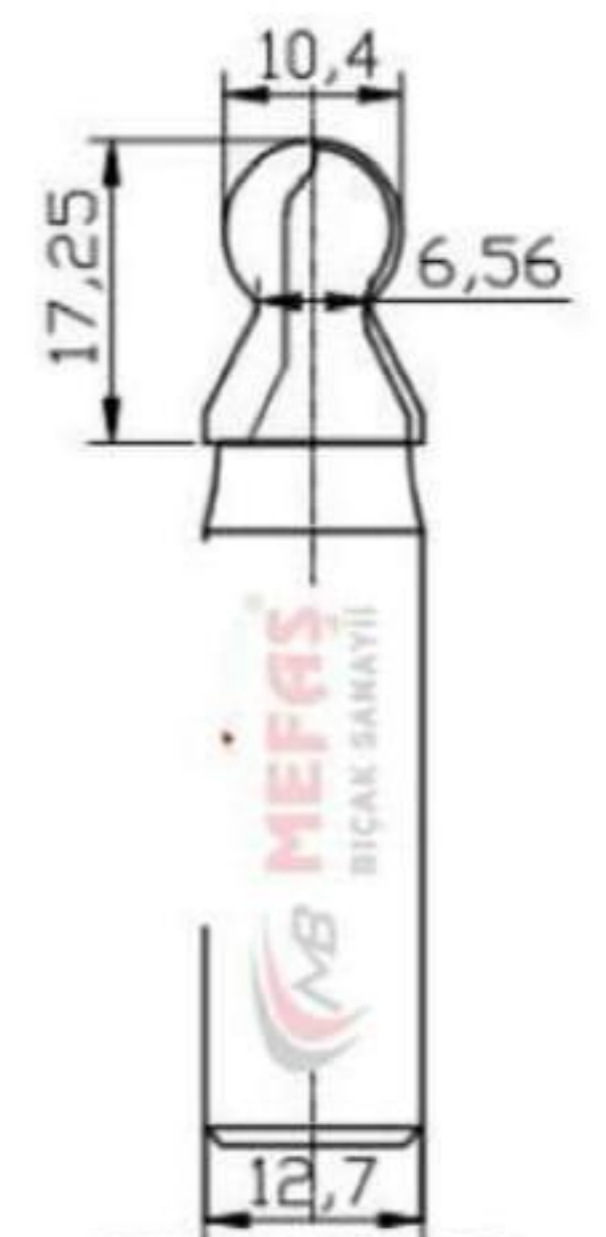
ST0711229/JY

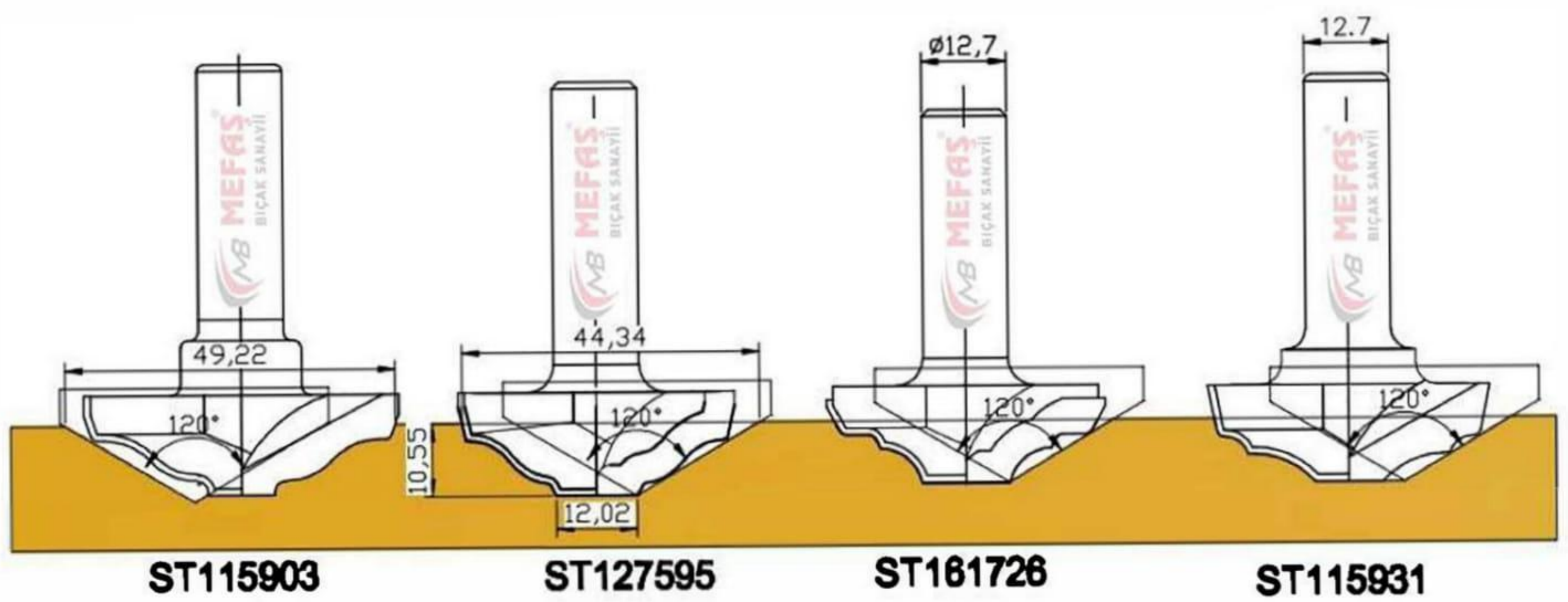
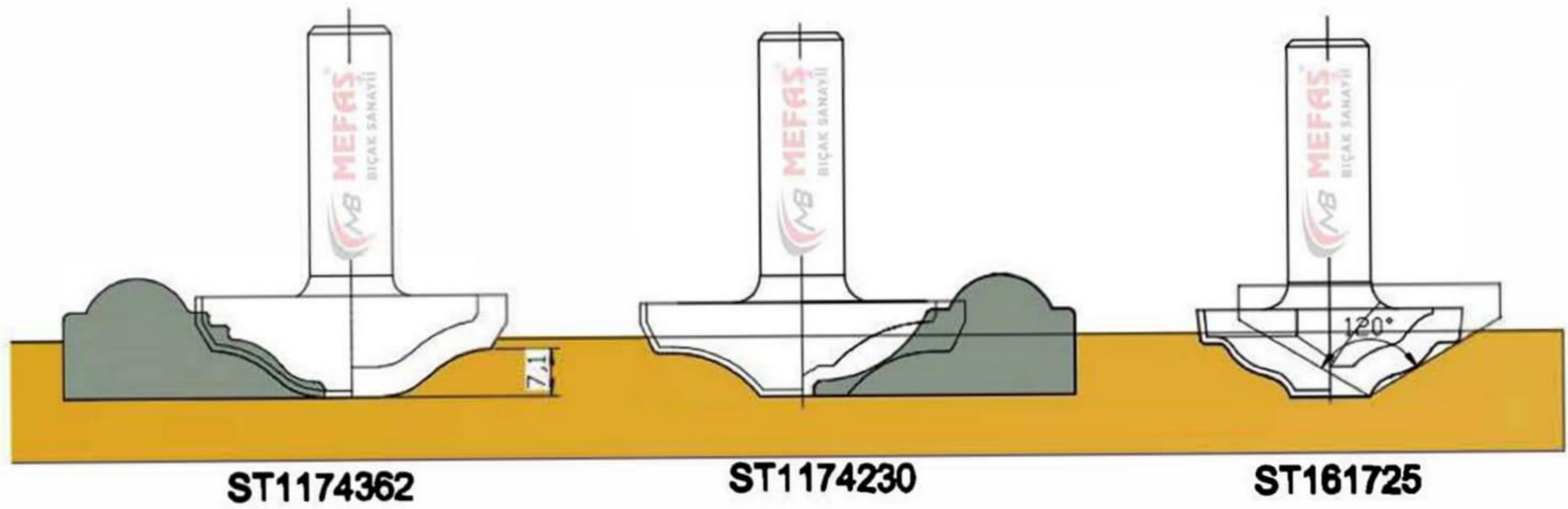
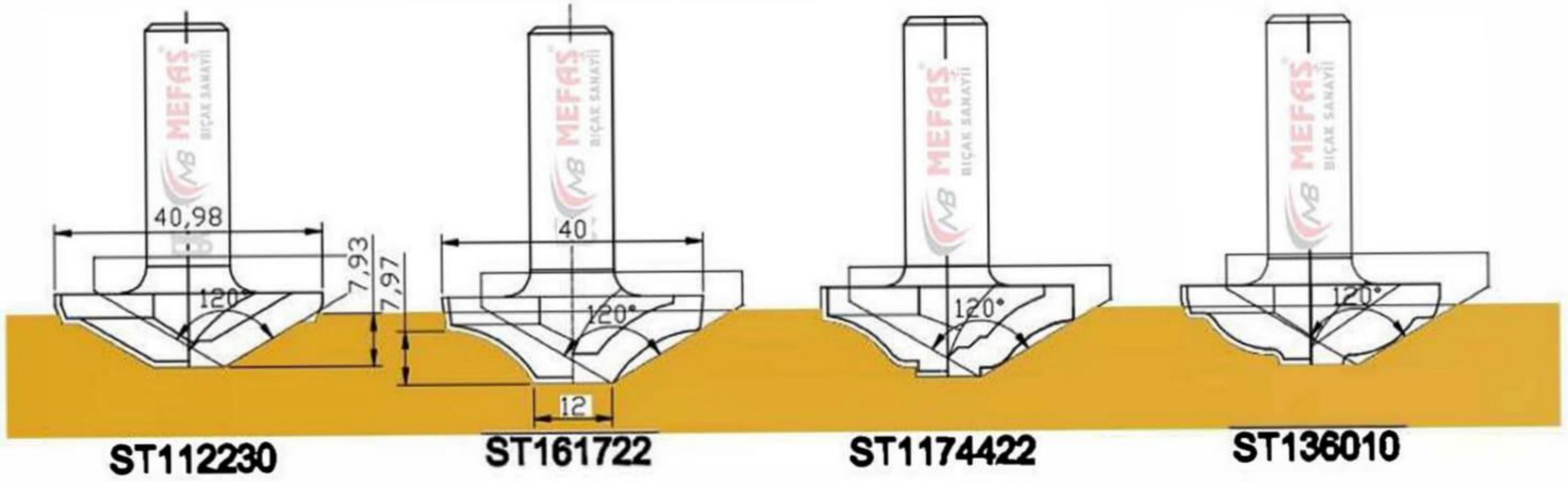
ST0711239/GL

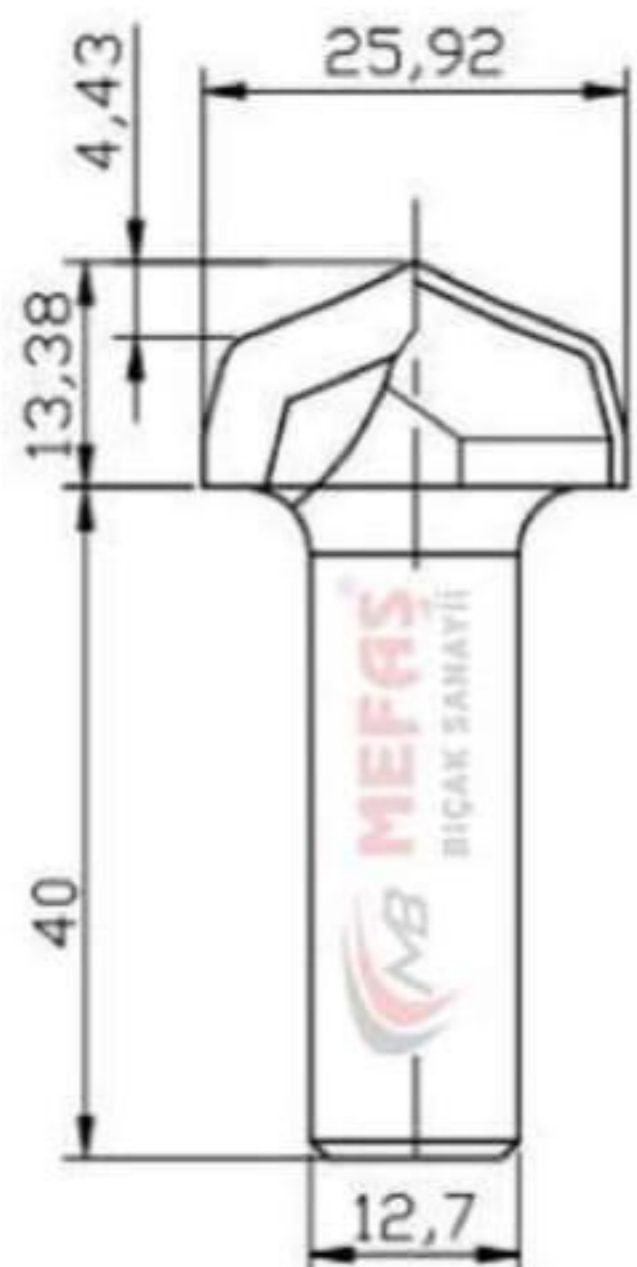
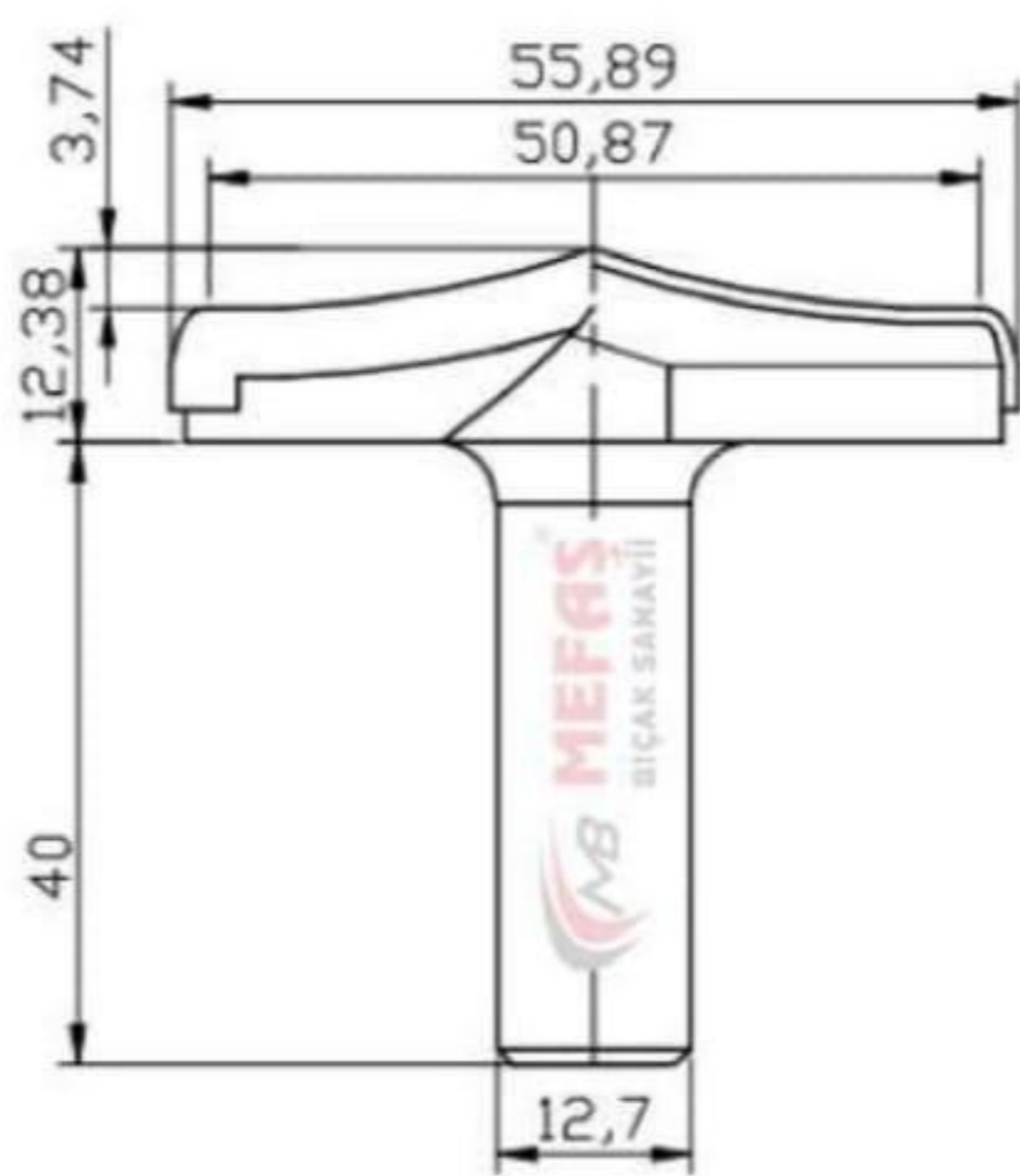
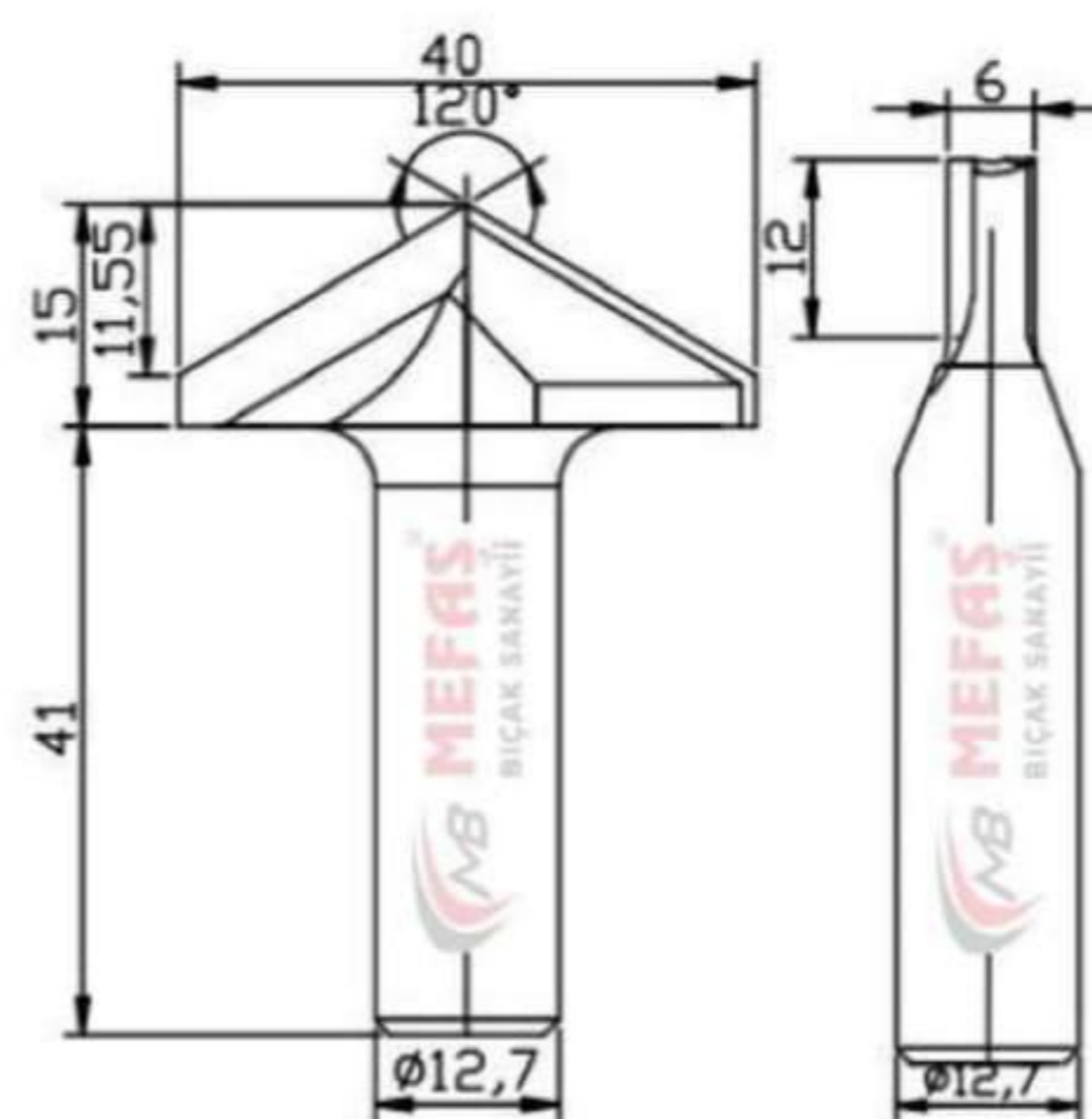
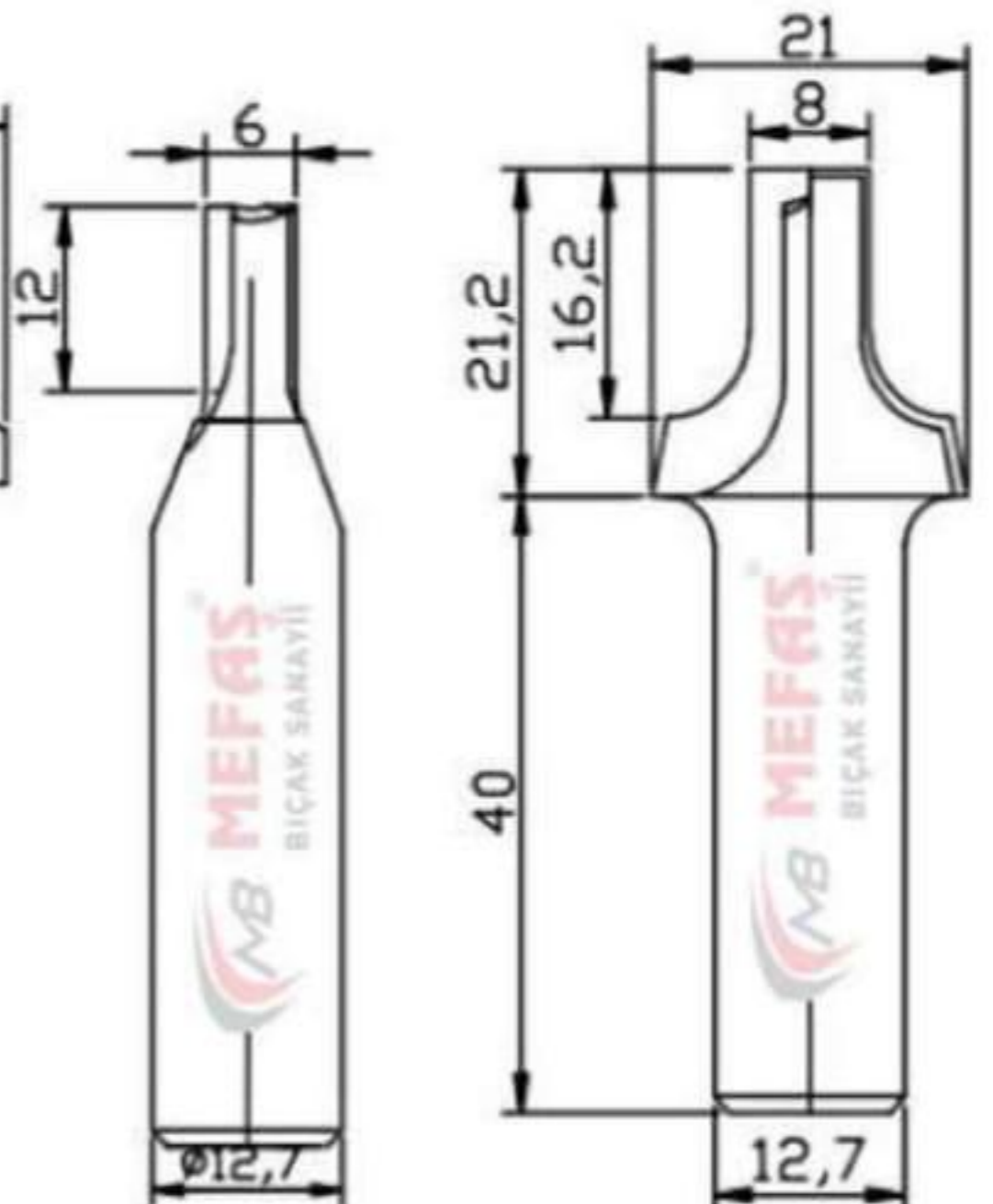
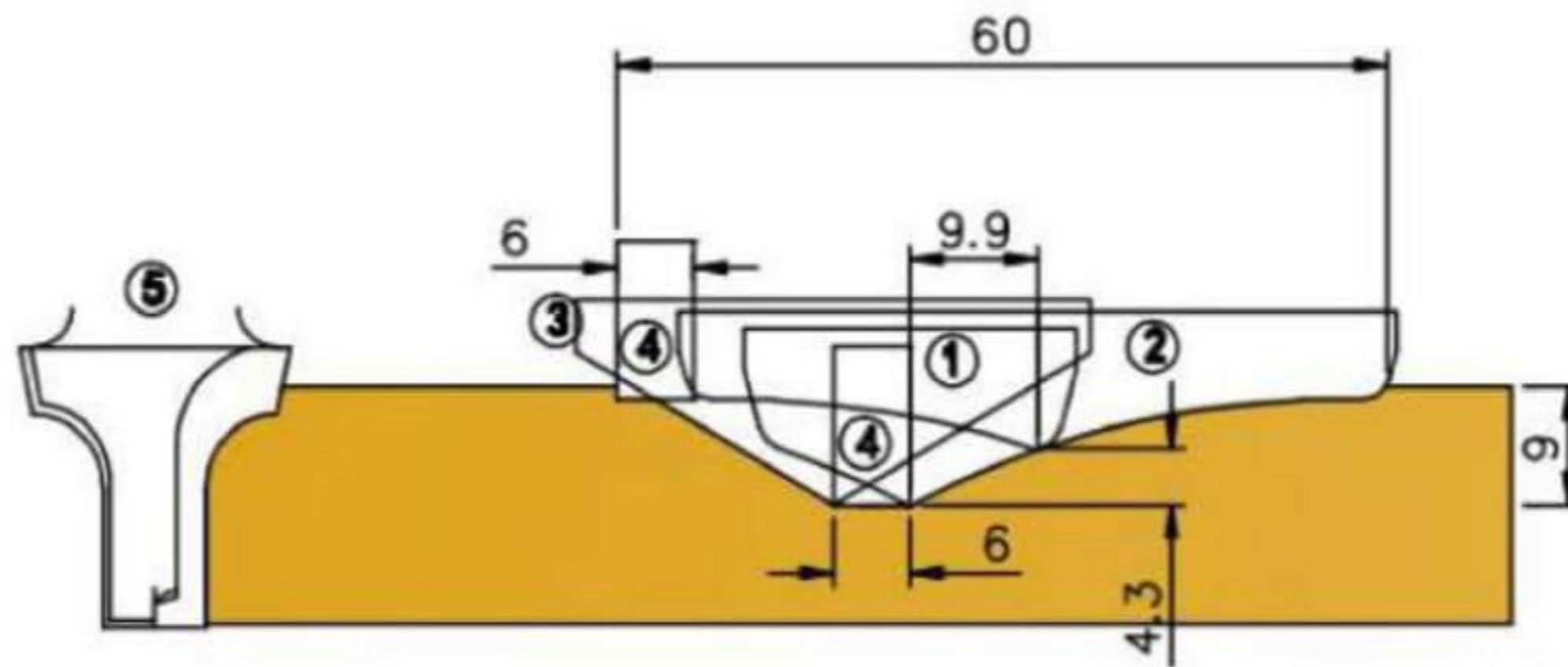
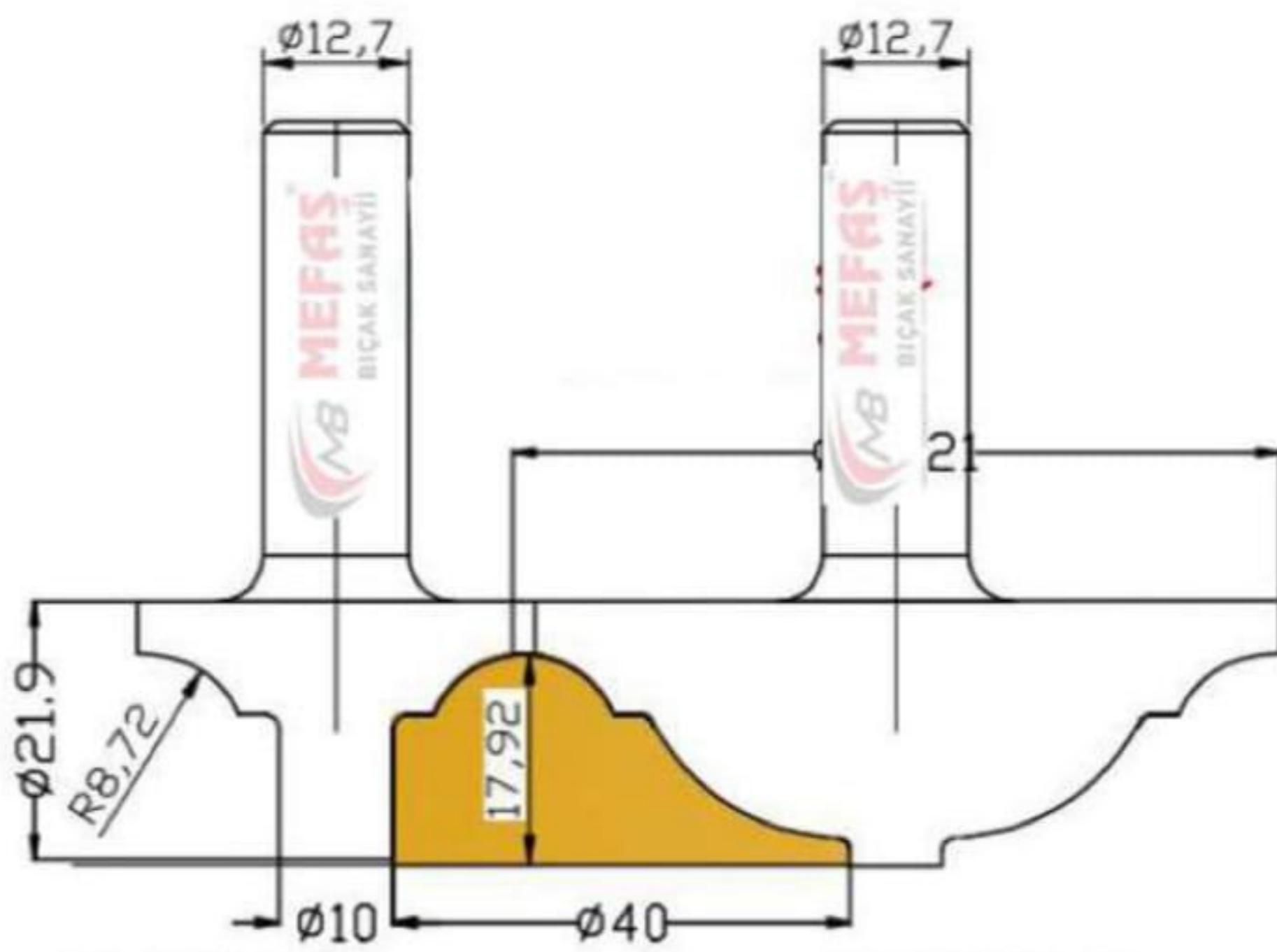
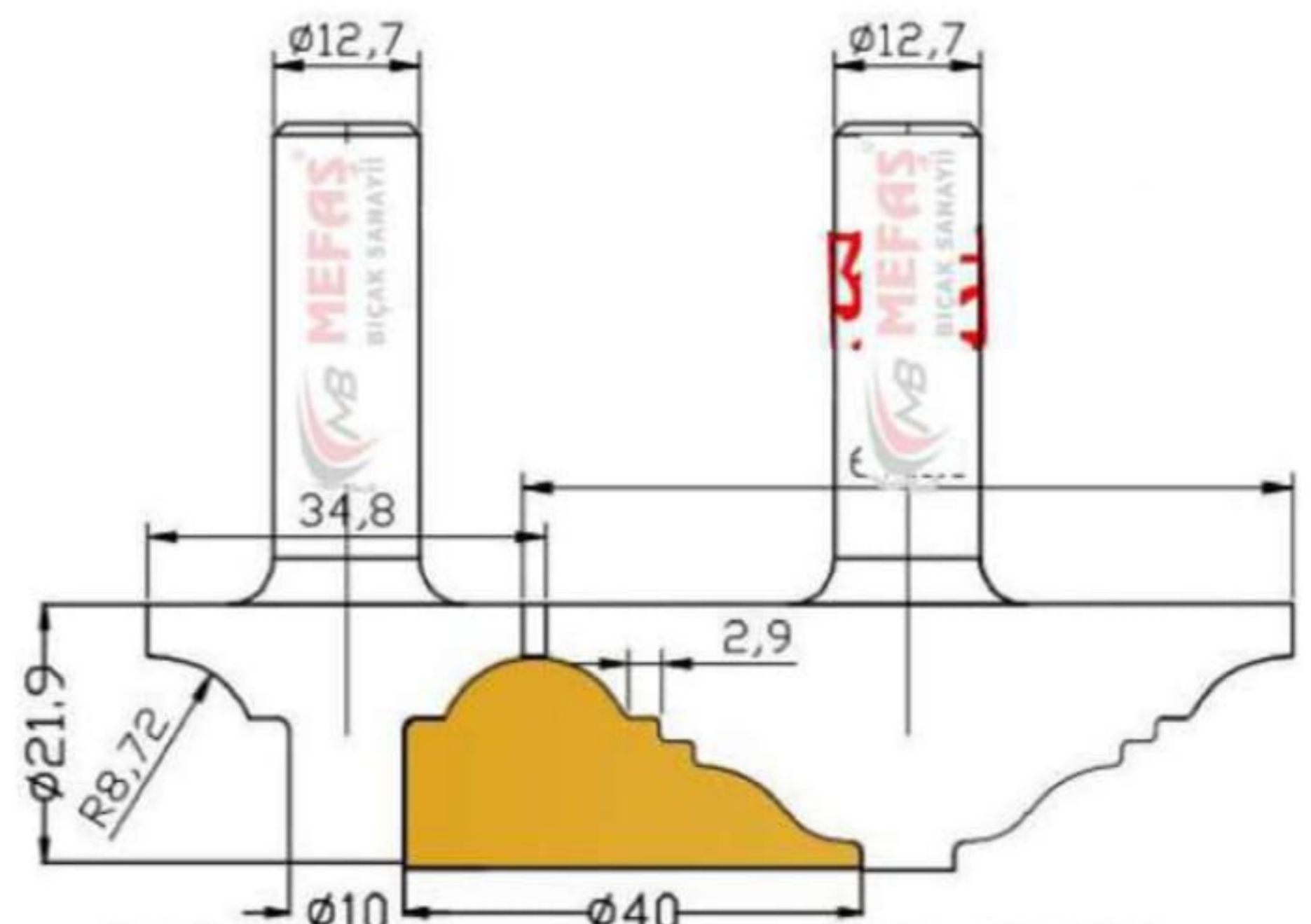
ST0711229 H12.1

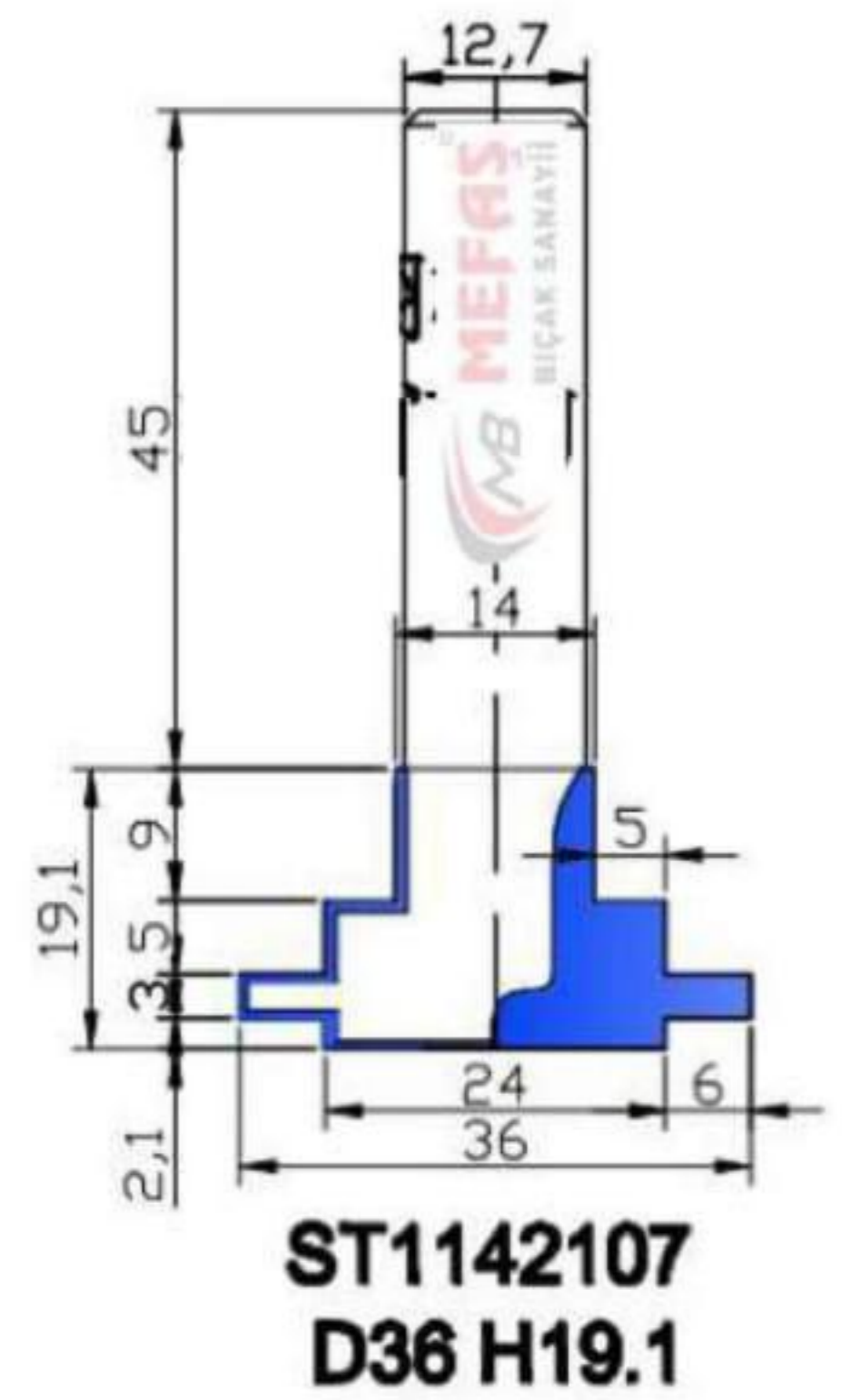
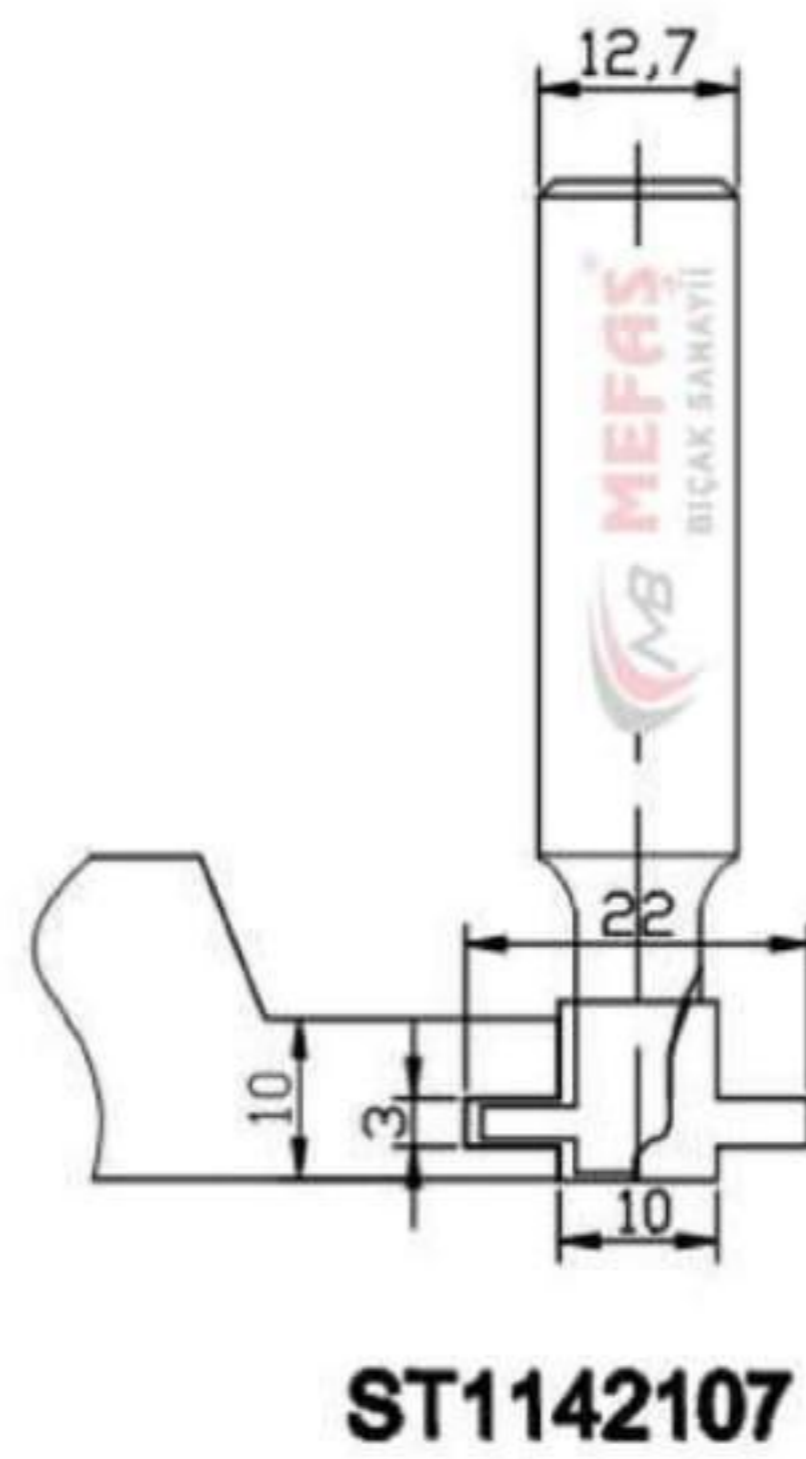
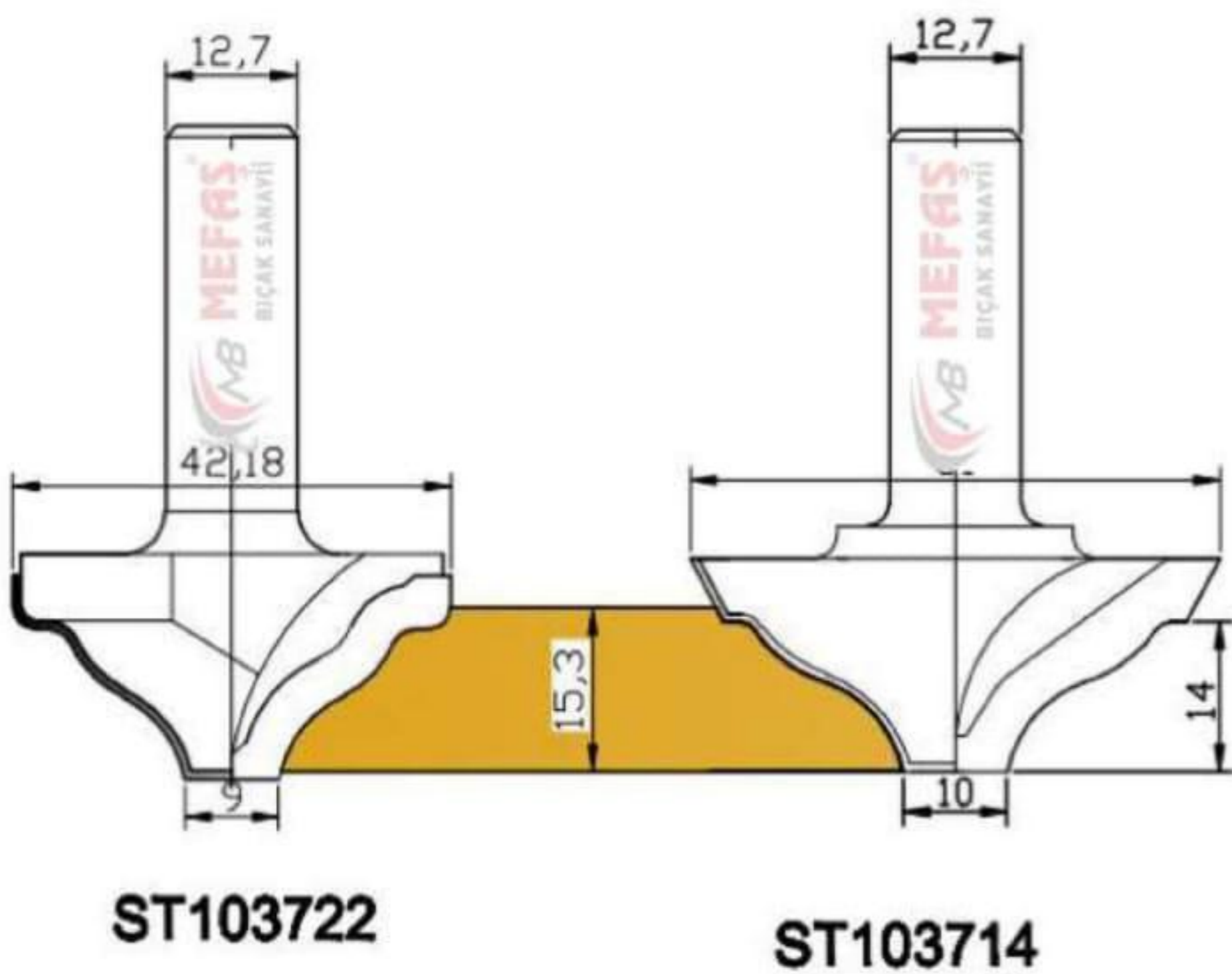
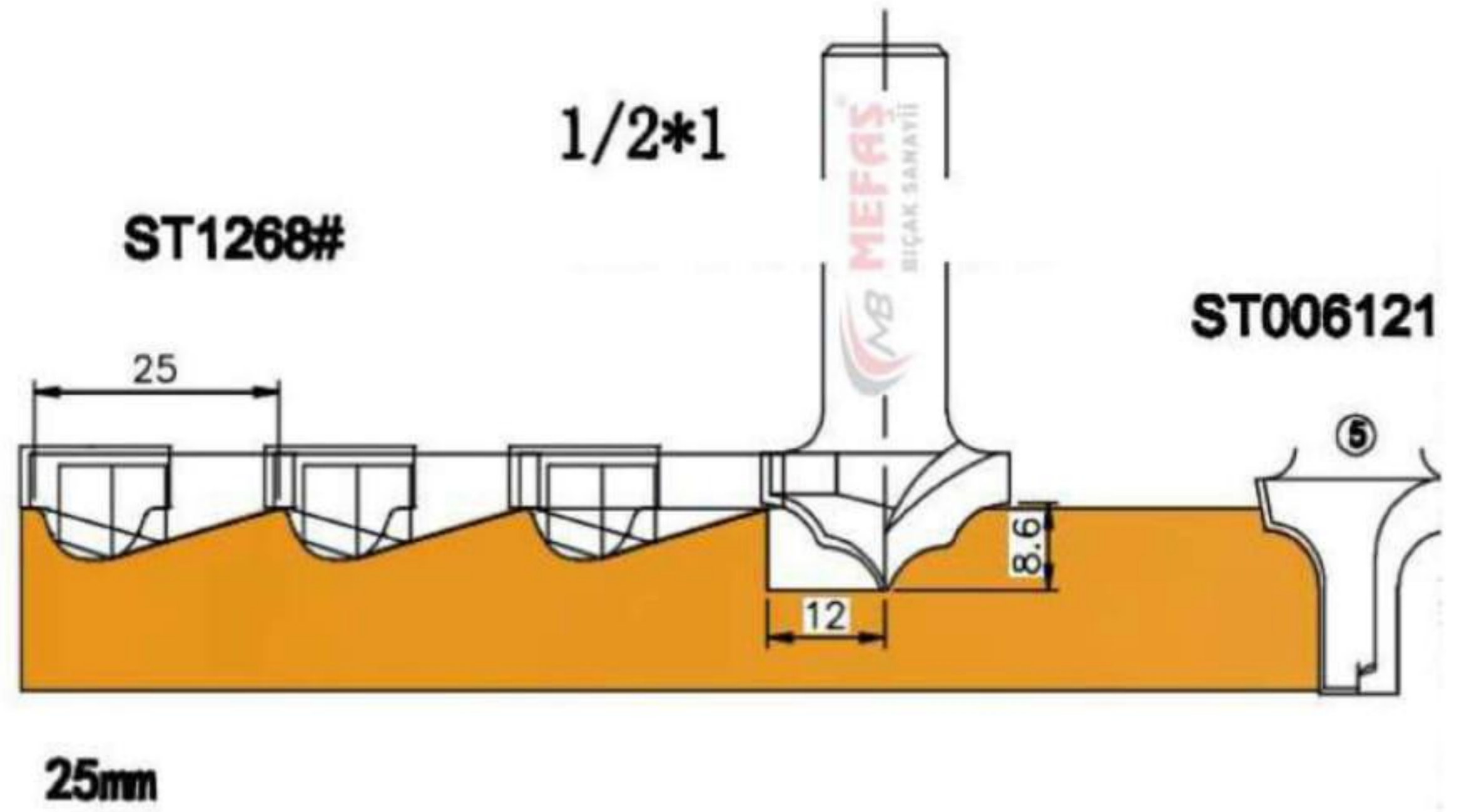
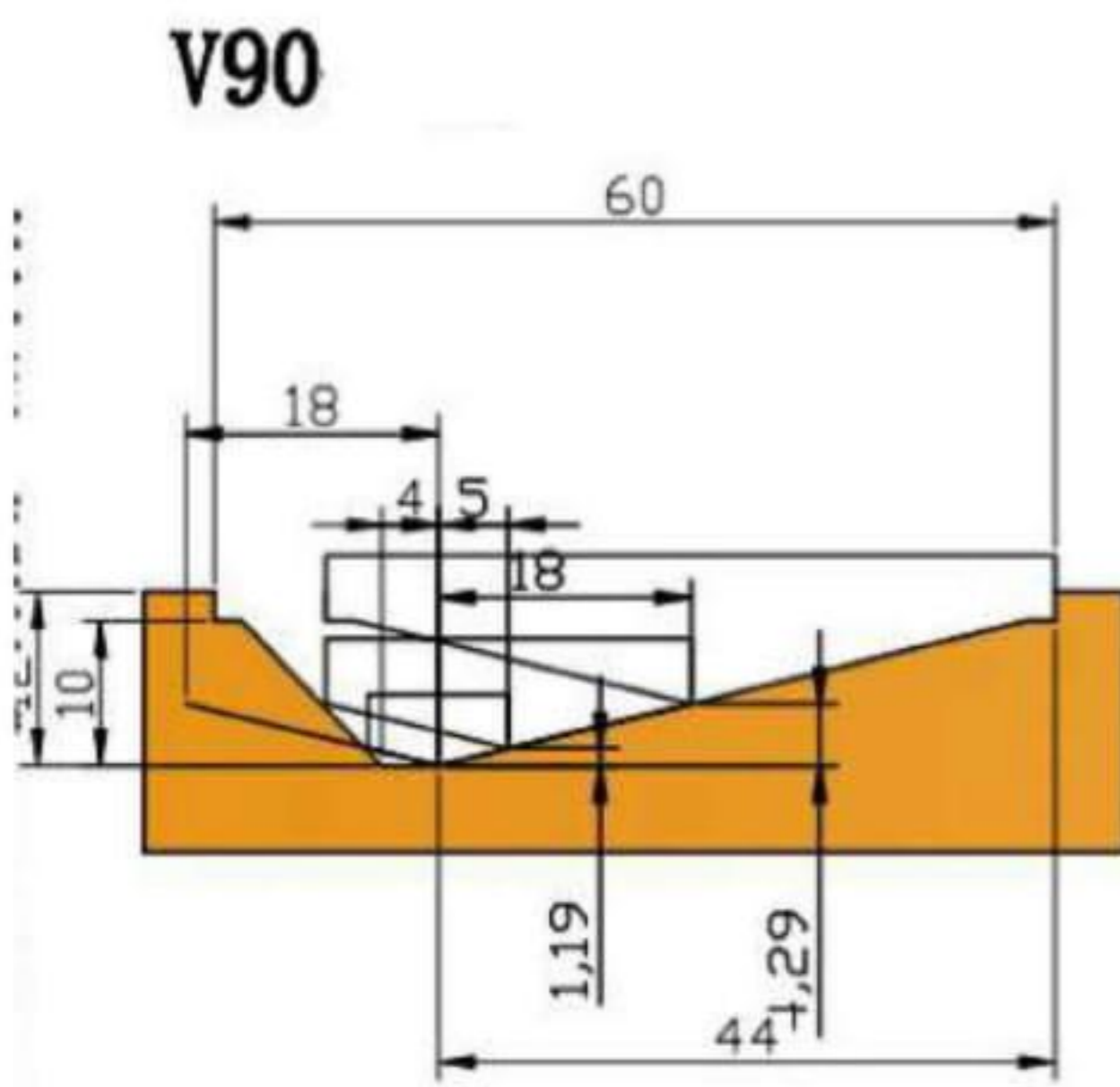
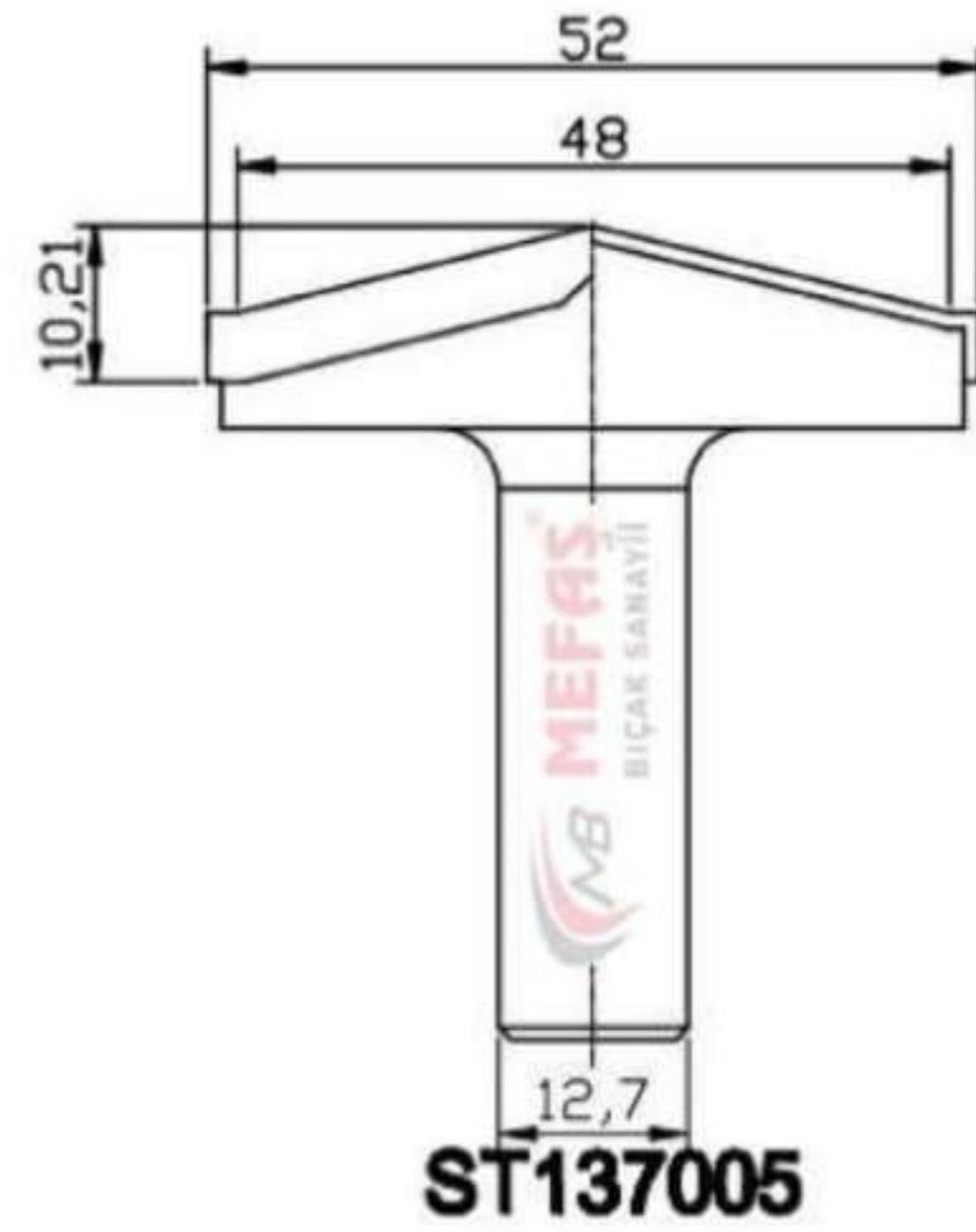
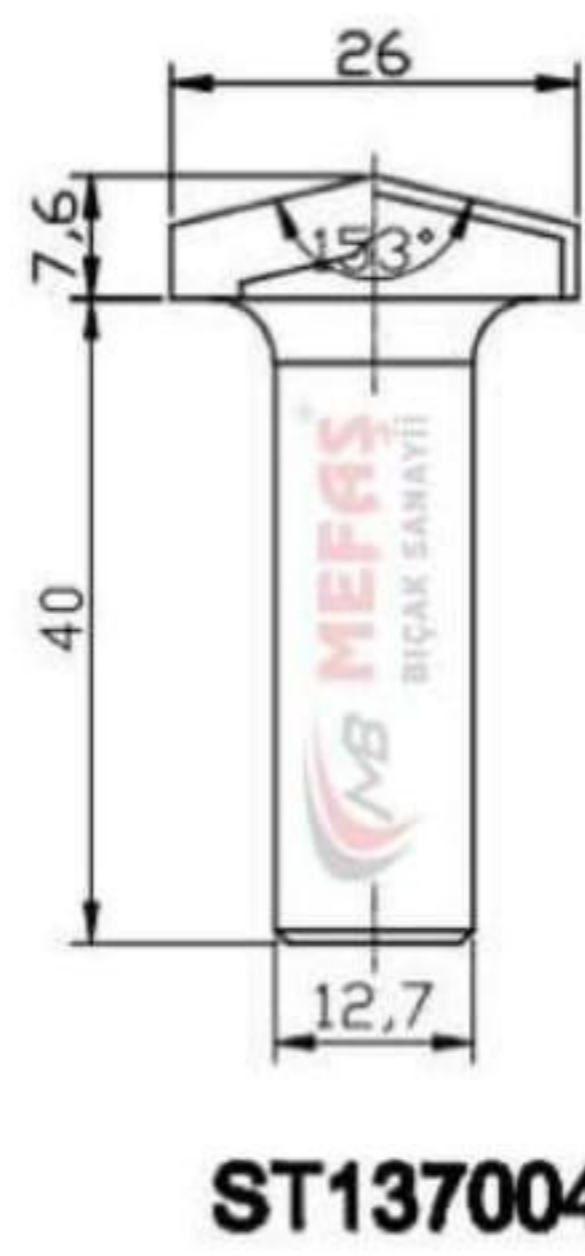
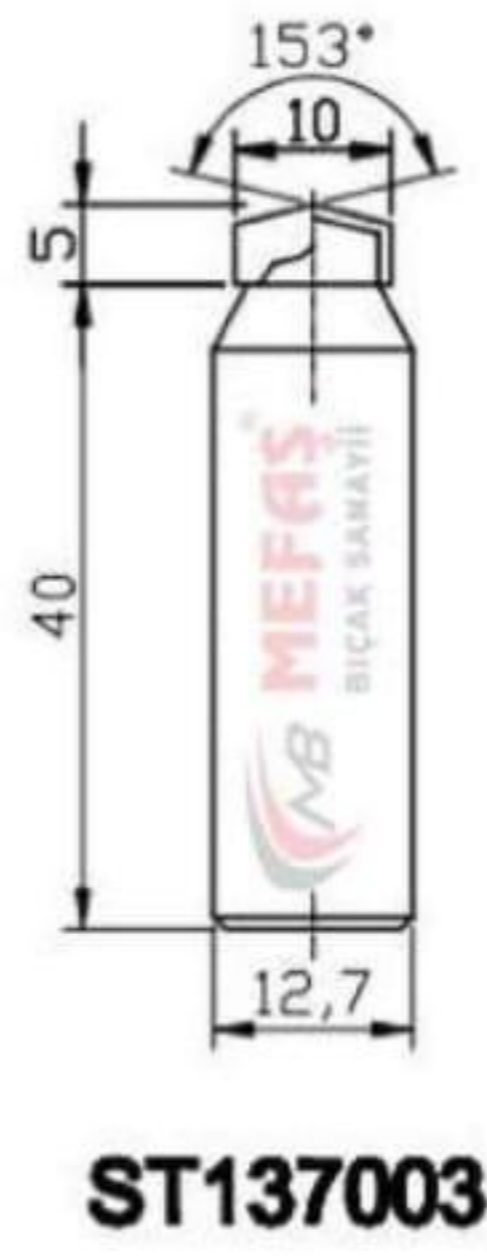
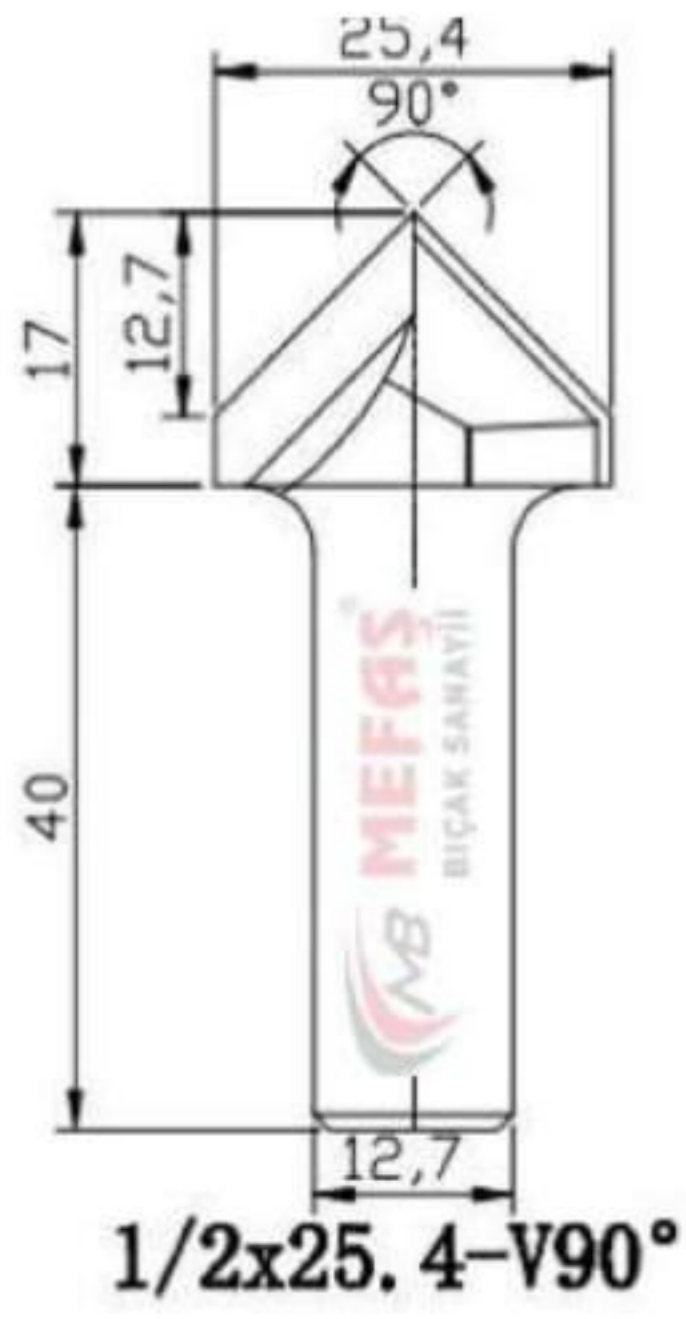
ST1196197

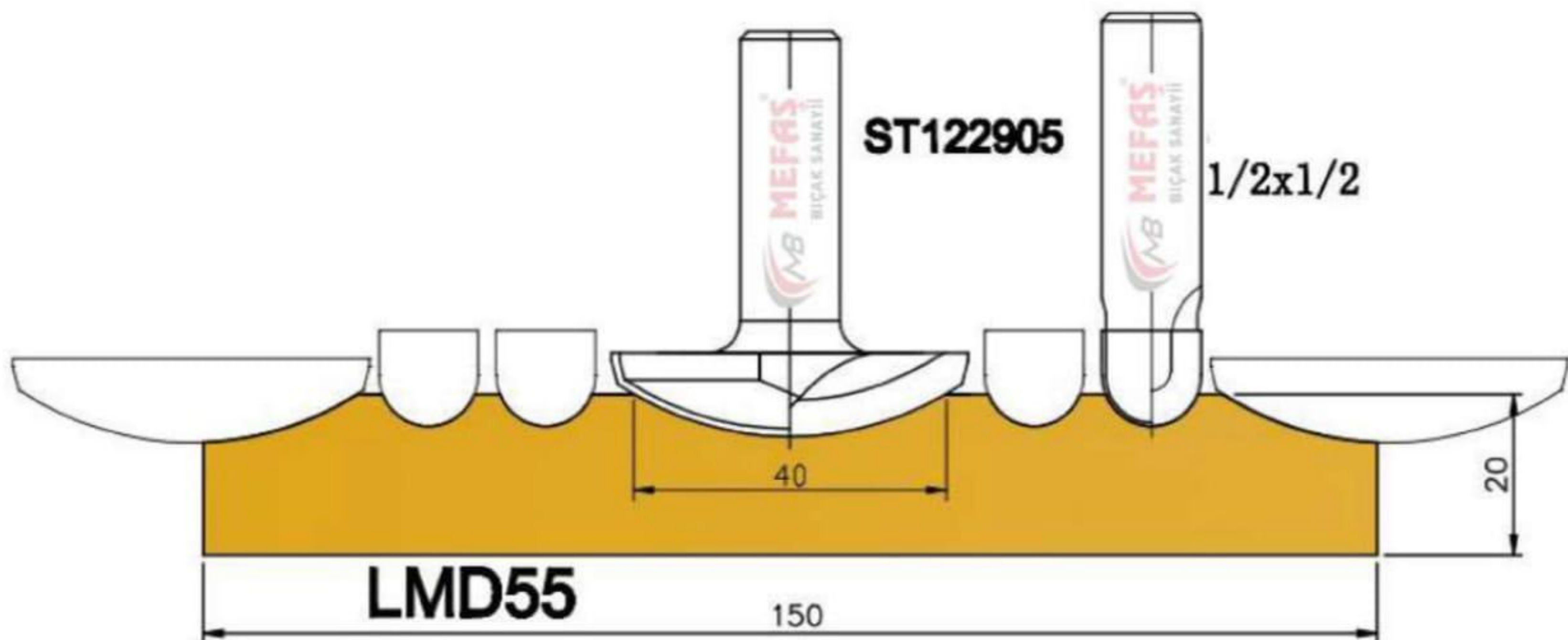
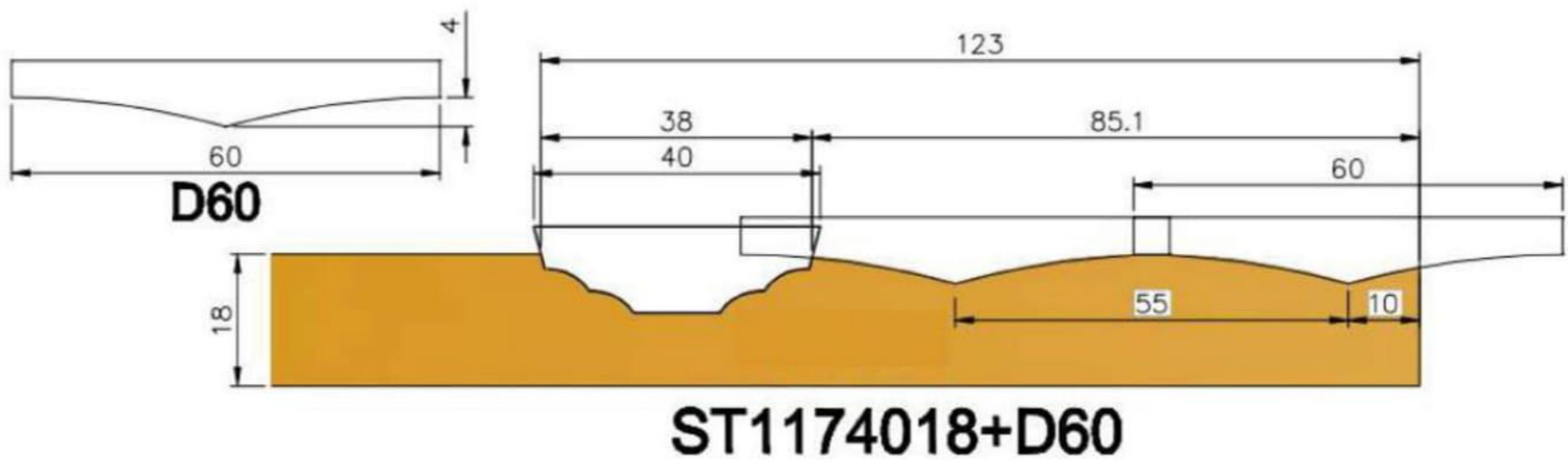
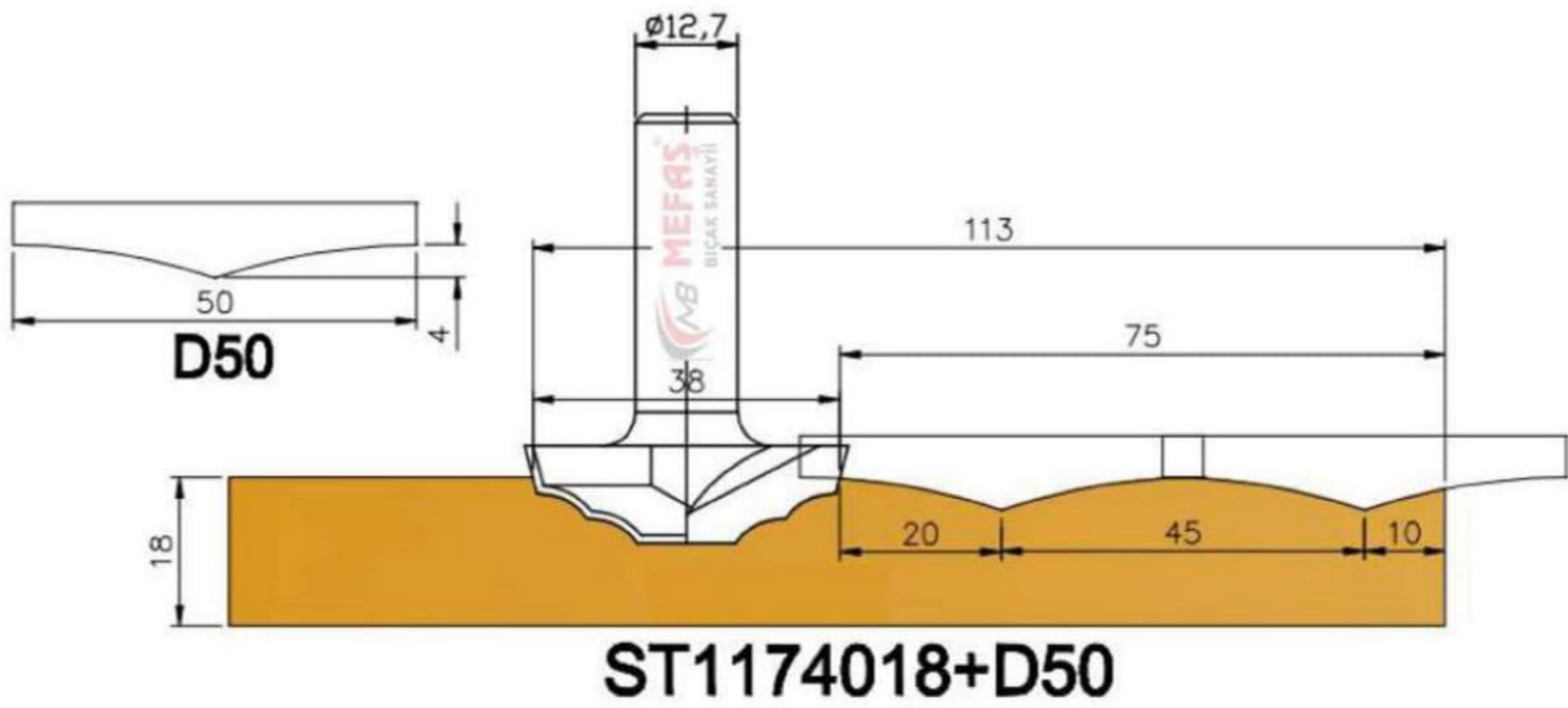
ST0711229-D24.6

ST1196193G

ST071117-H10.5

ST0711229-H13.6

ST70214

ST071-d10.3

ST071-10.5/JY

ST122142

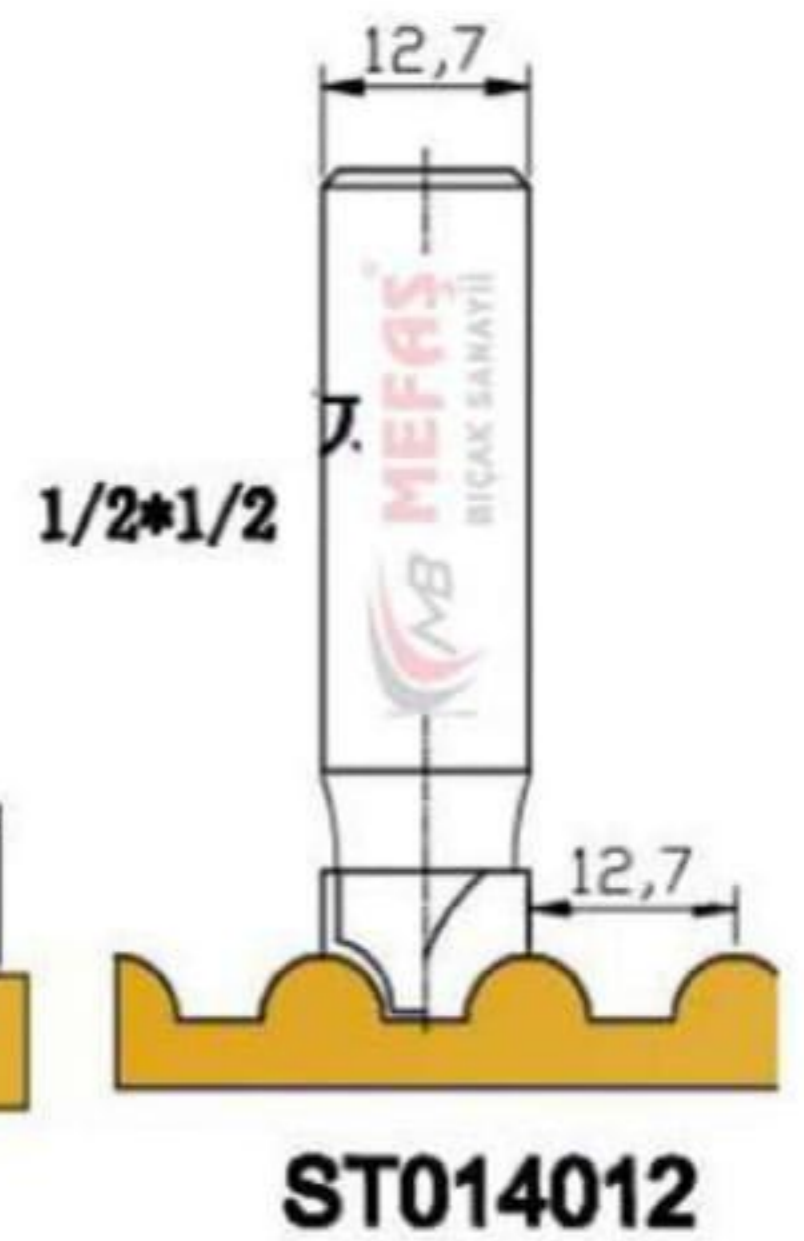
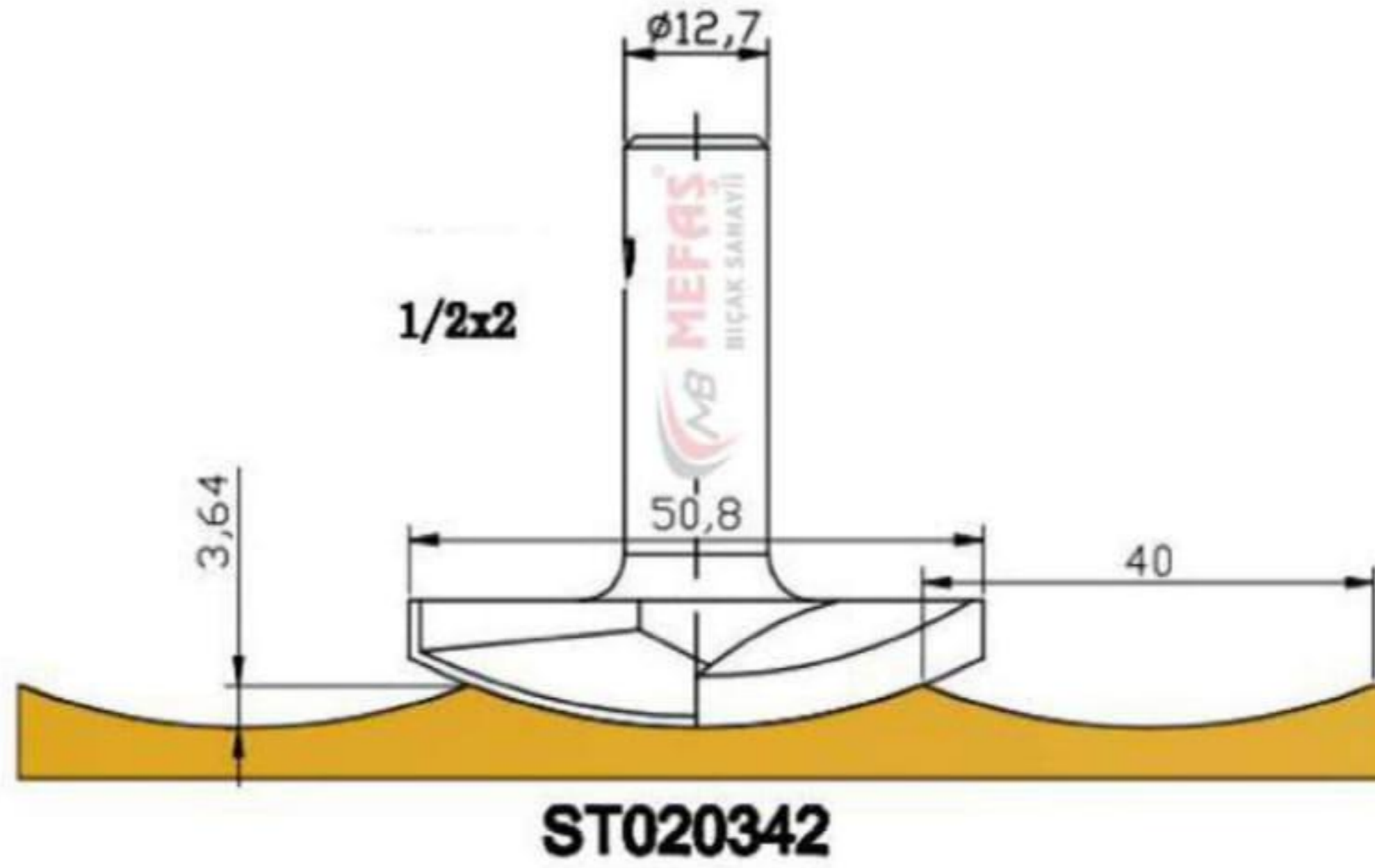
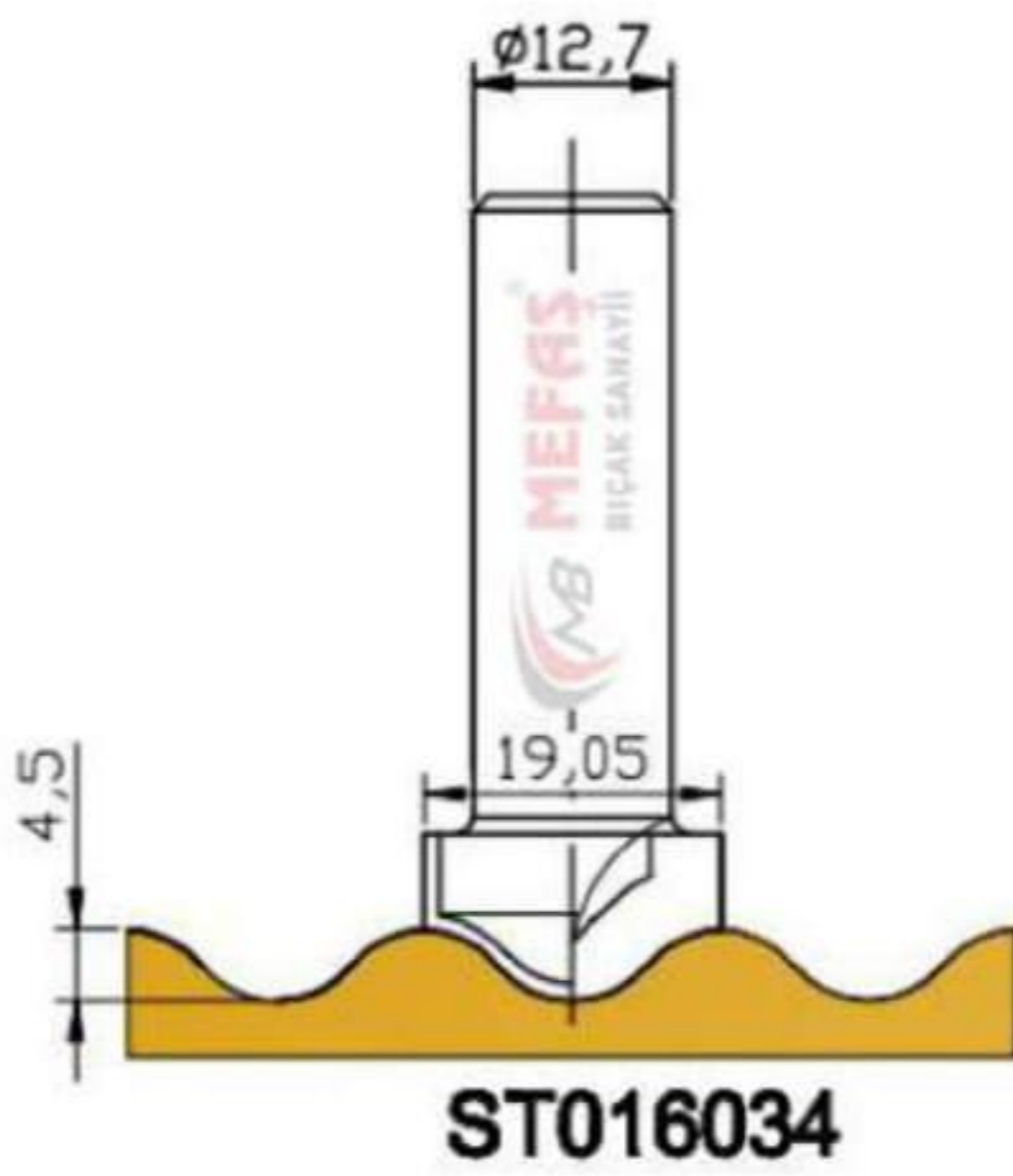
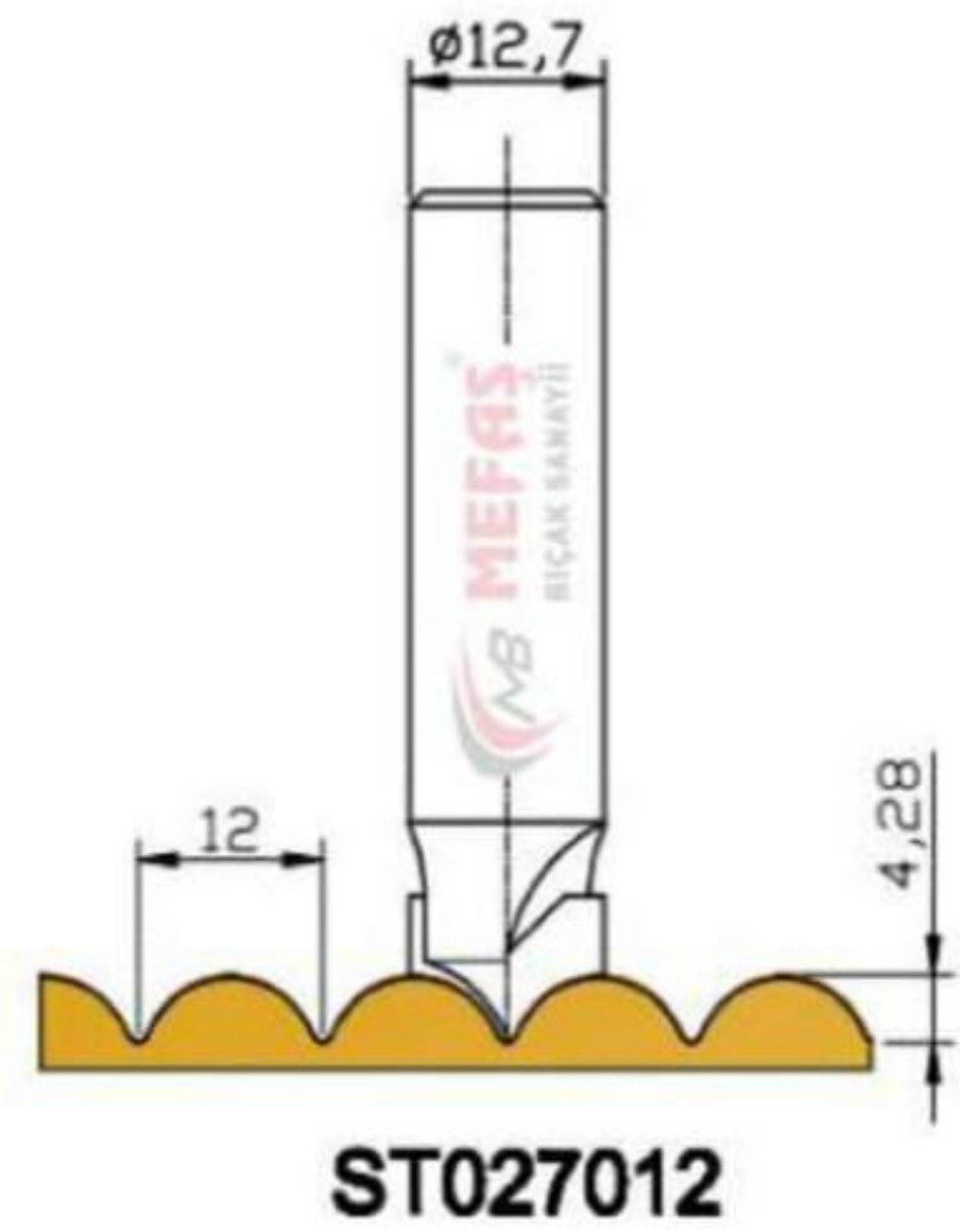
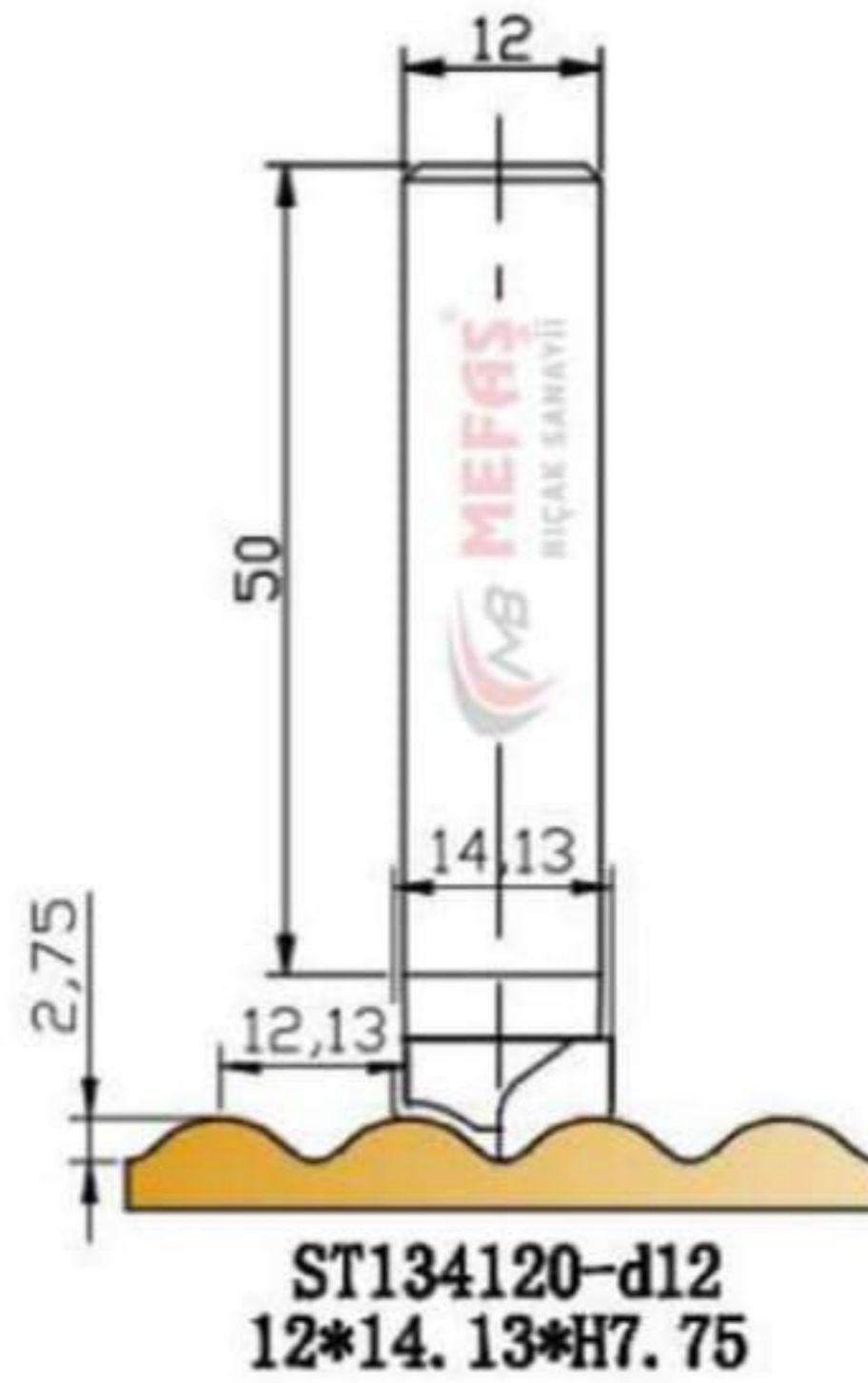
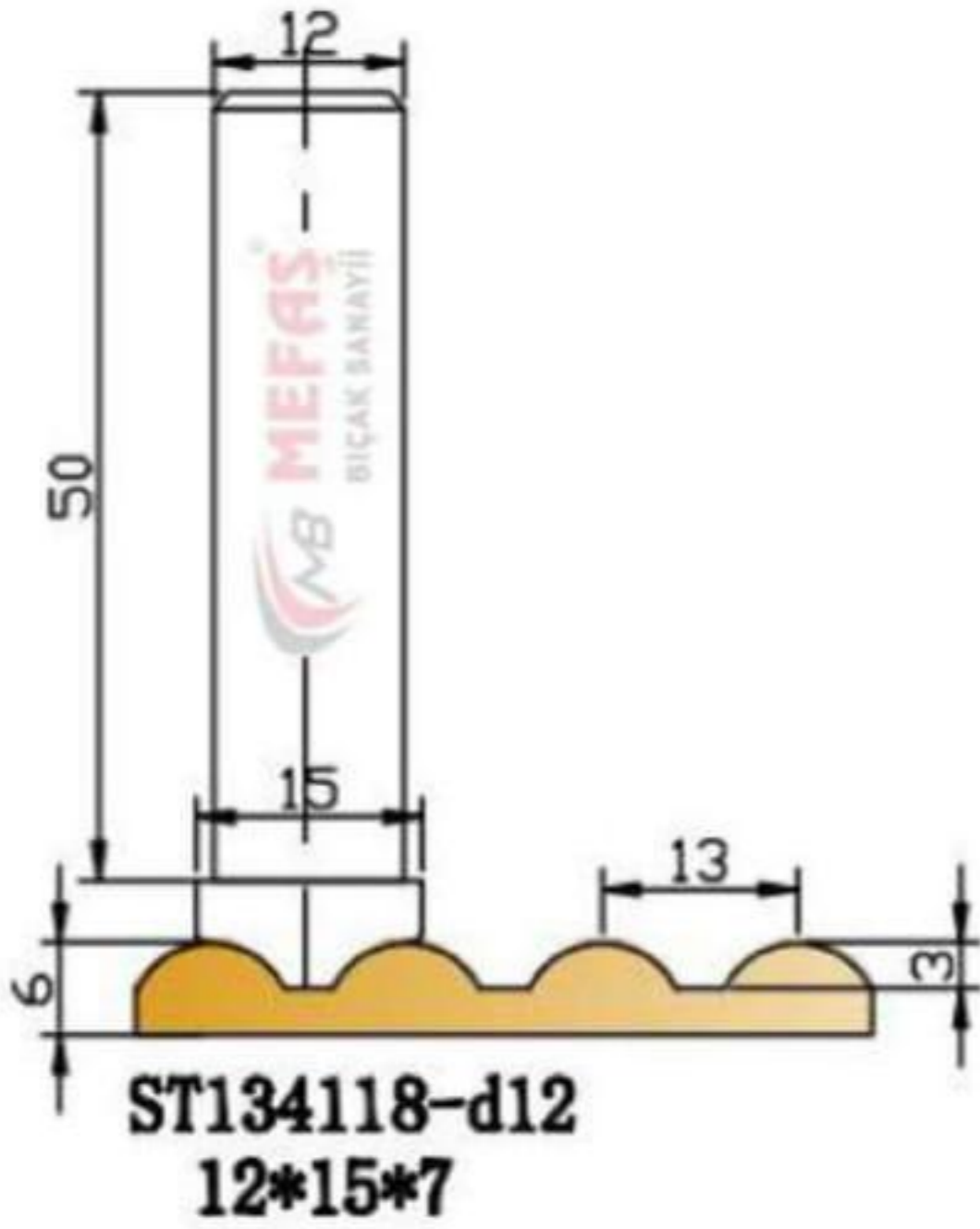
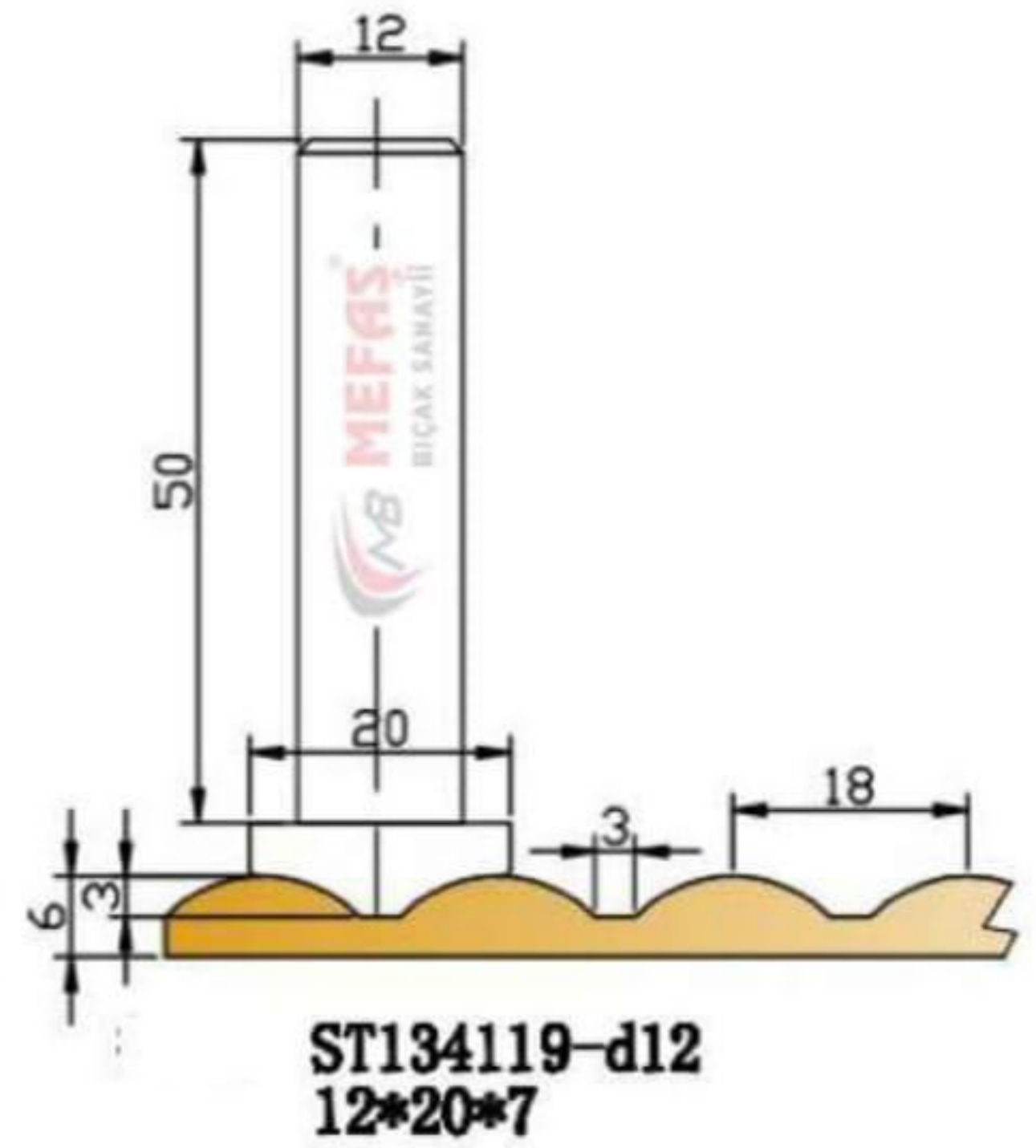
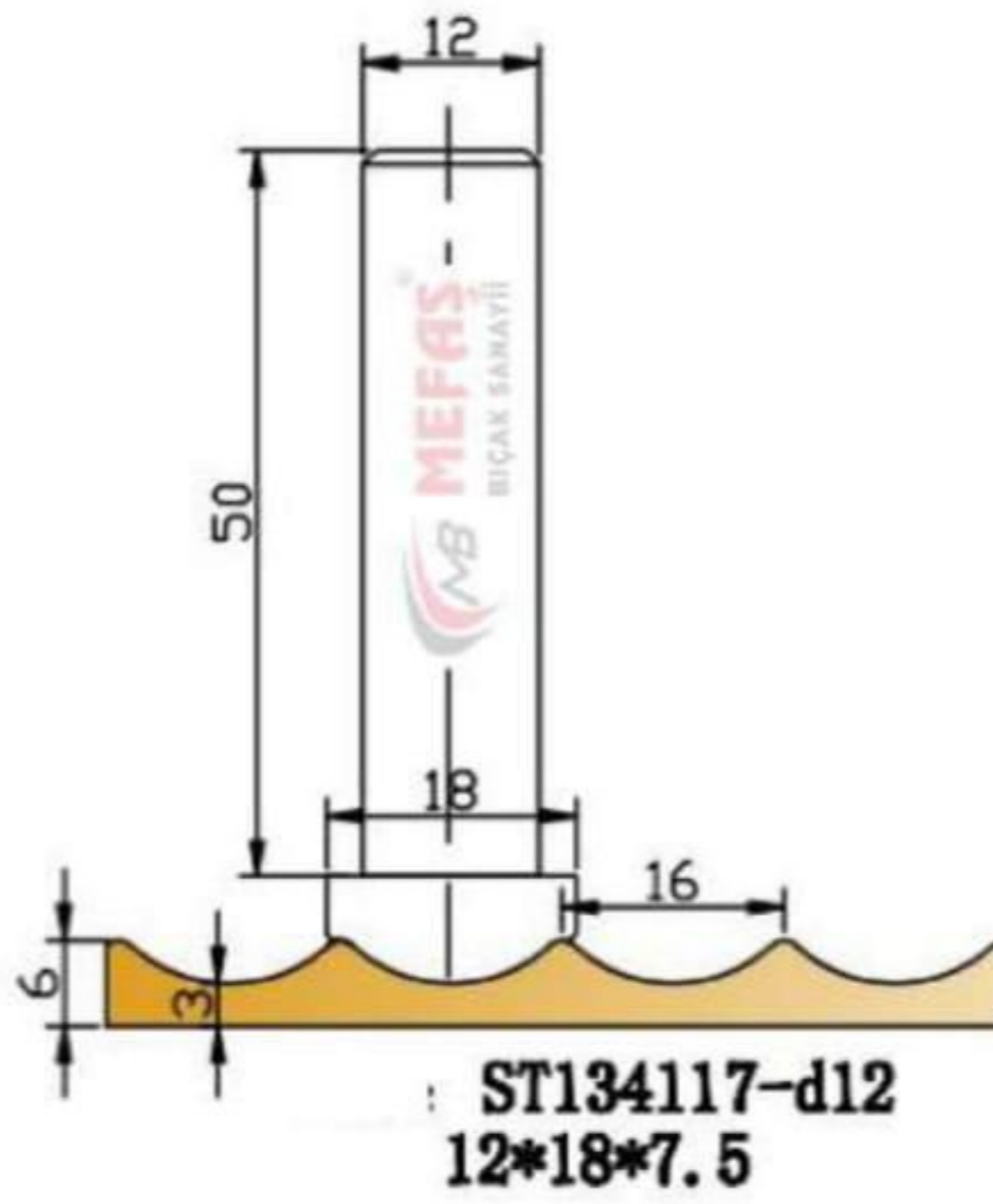
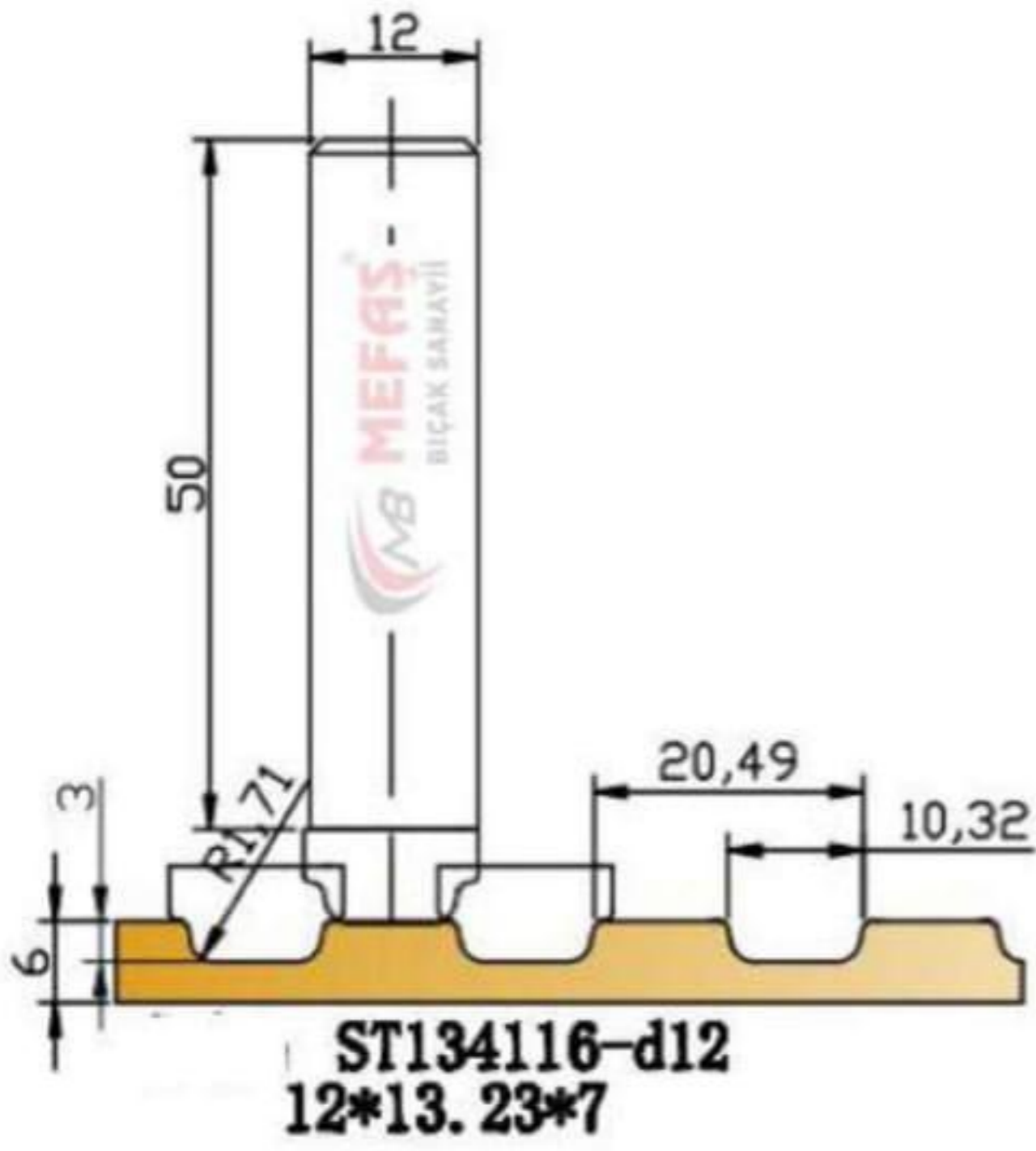
ST1292242G





ST127534

ST127535

ST12.7X40-120°

ST1/2*6*12 ST0061210

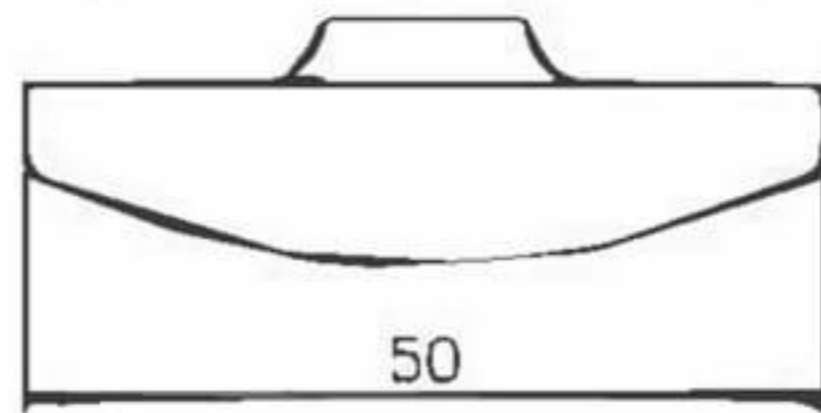
ST127534,

ST126861
ST126860

ST126861
ST126862







ST2017021601-D50



ST2017021602

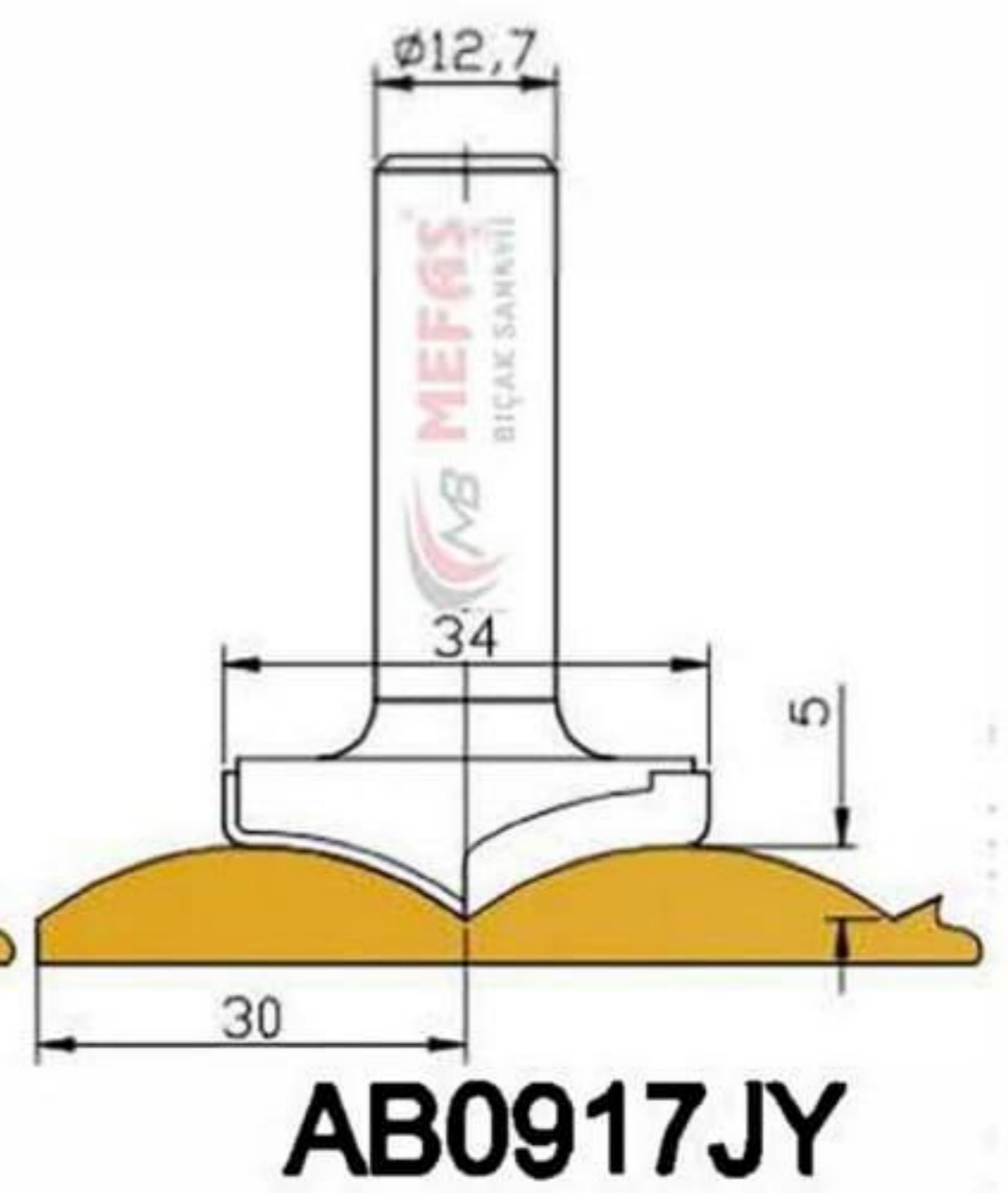
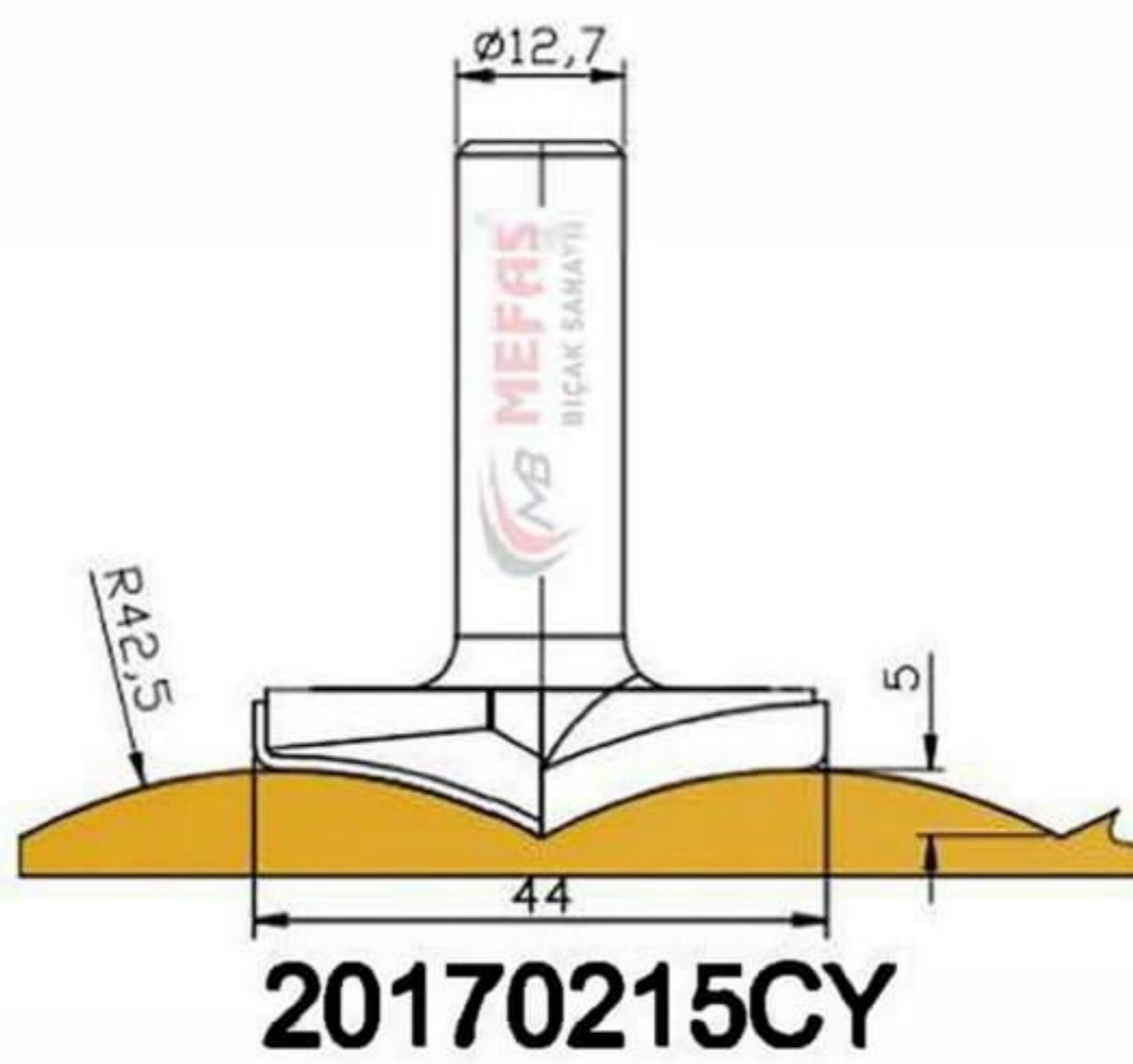
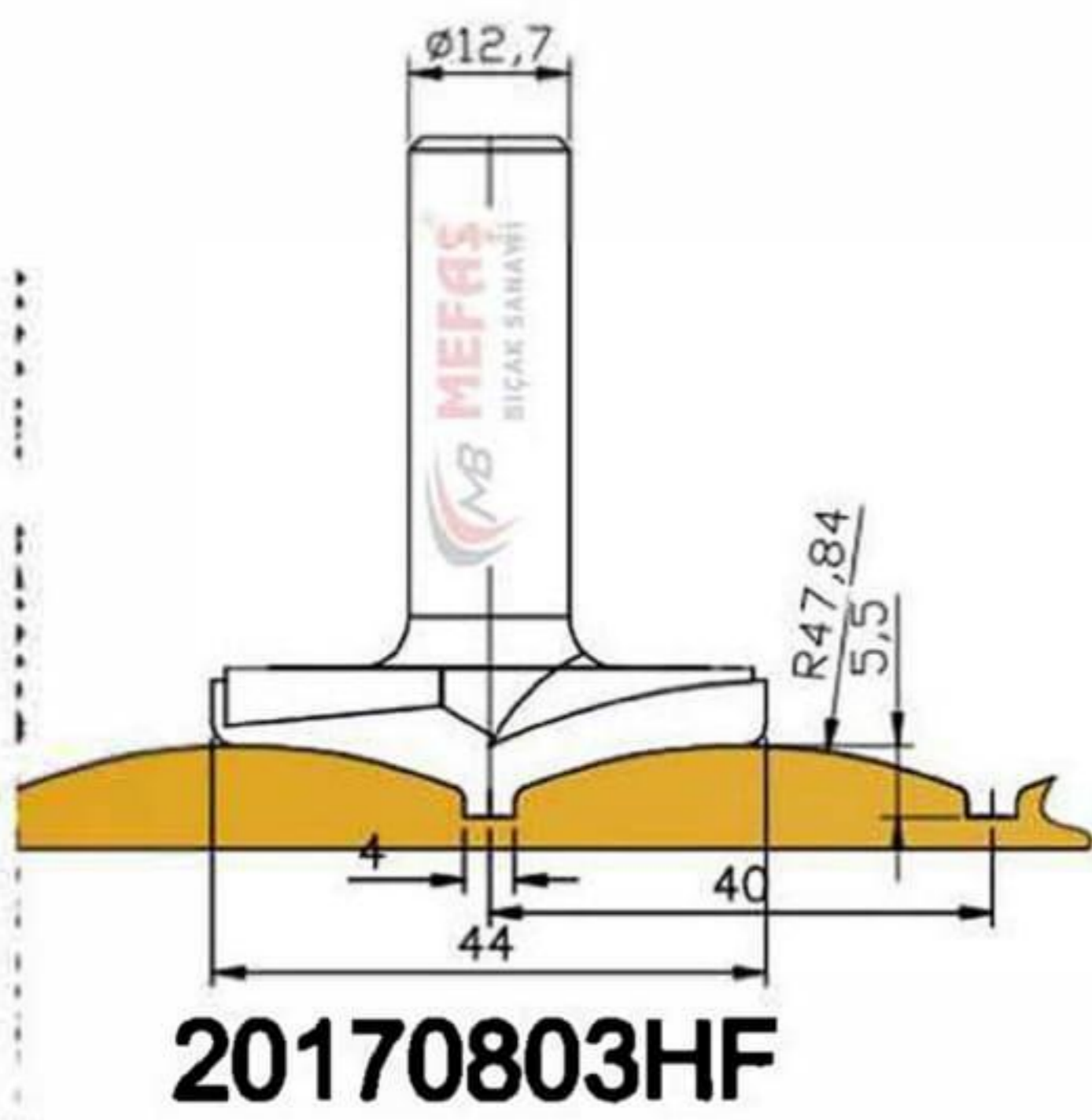
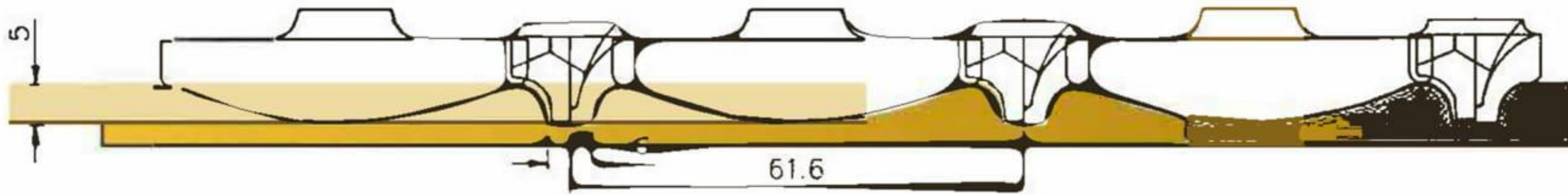

ST1268#

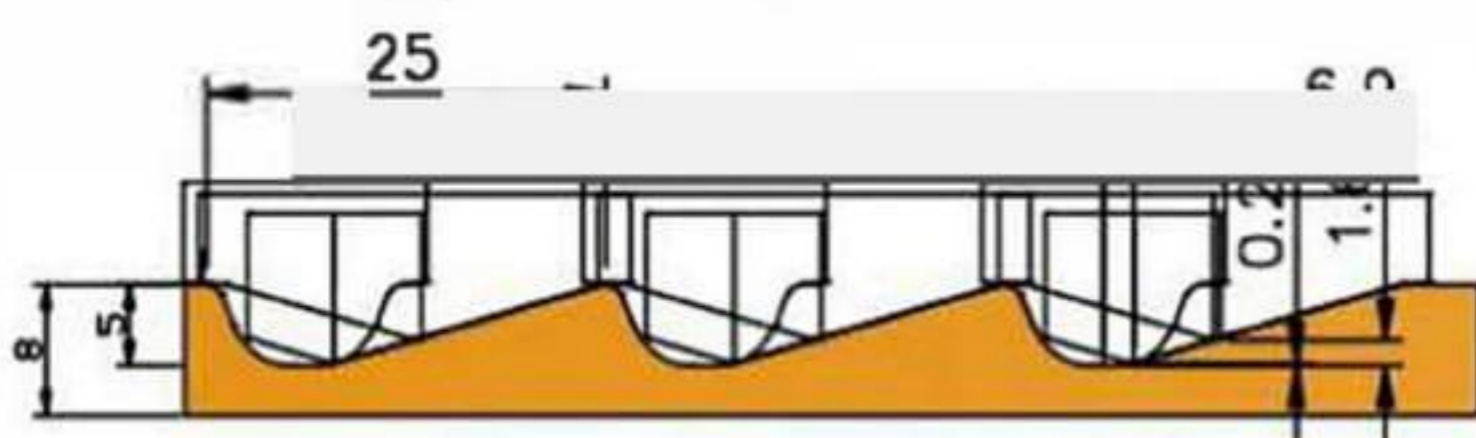
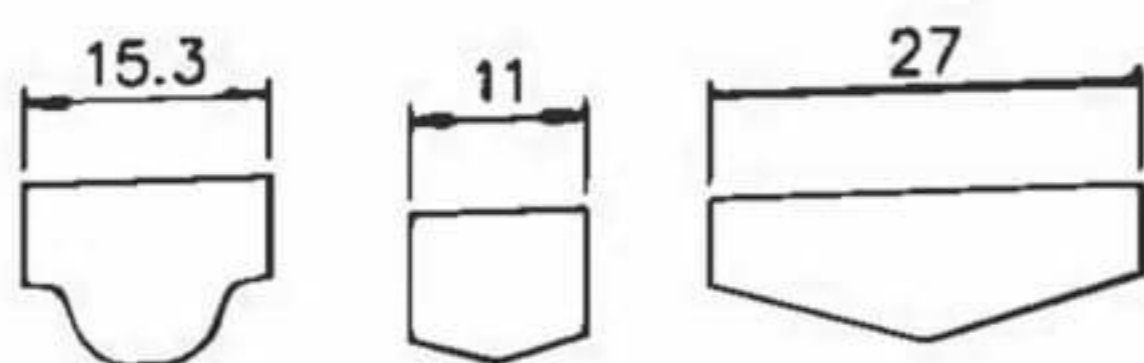

ST1565#

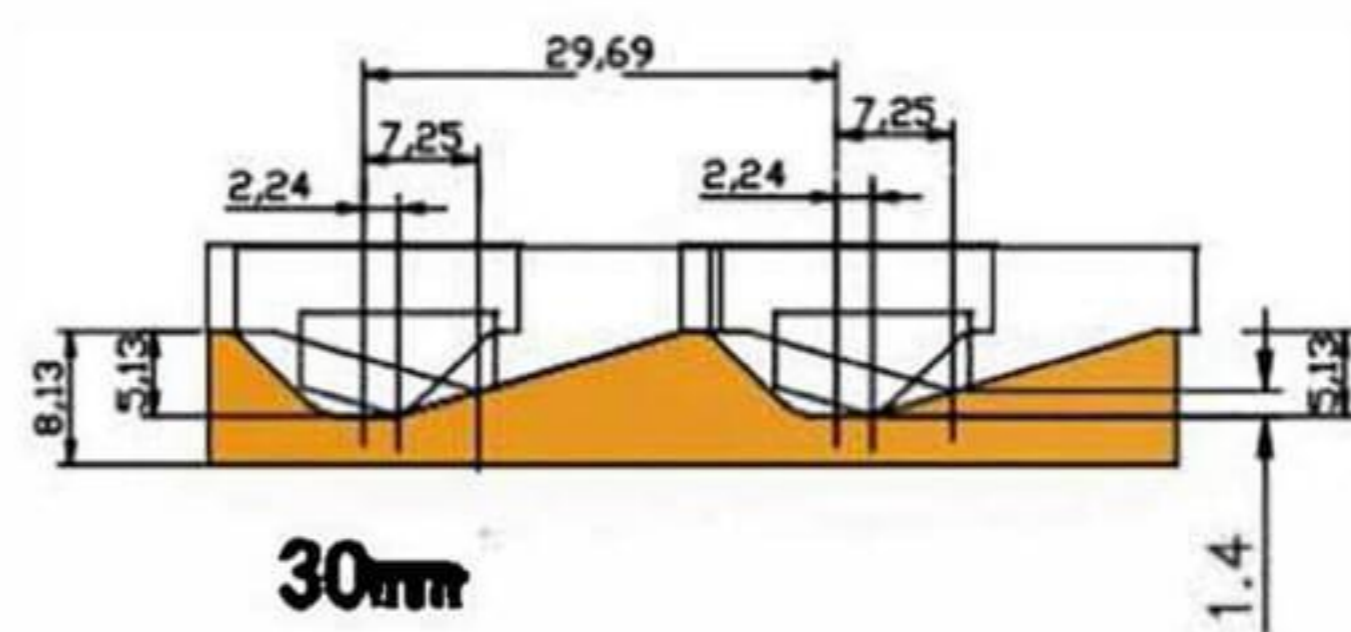
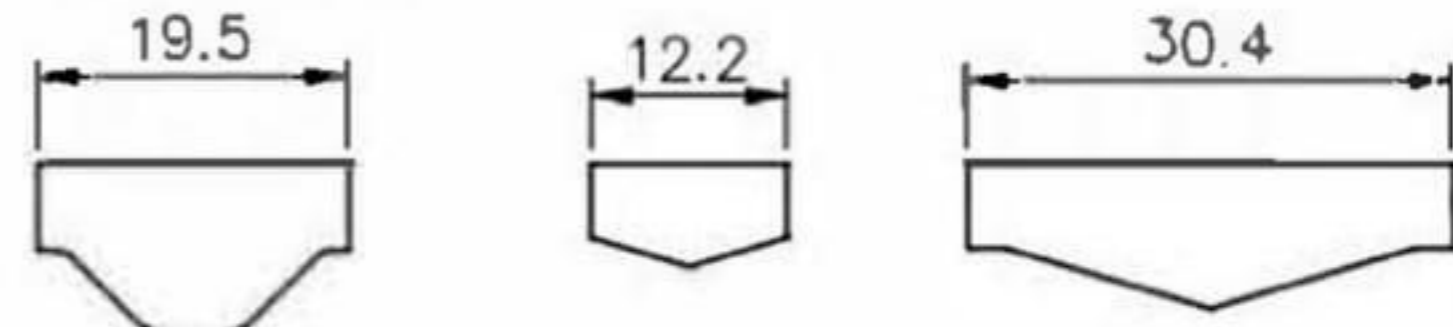

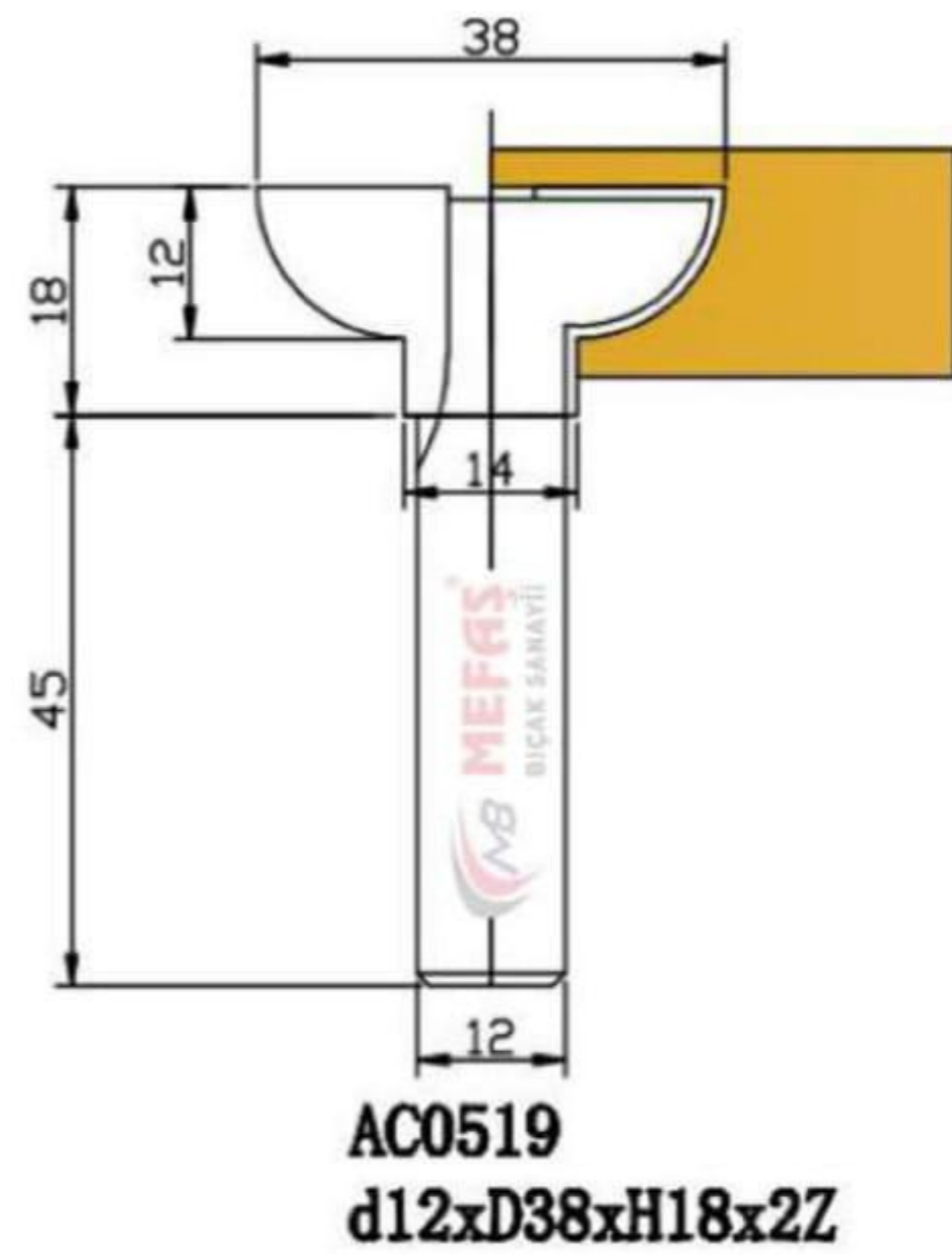
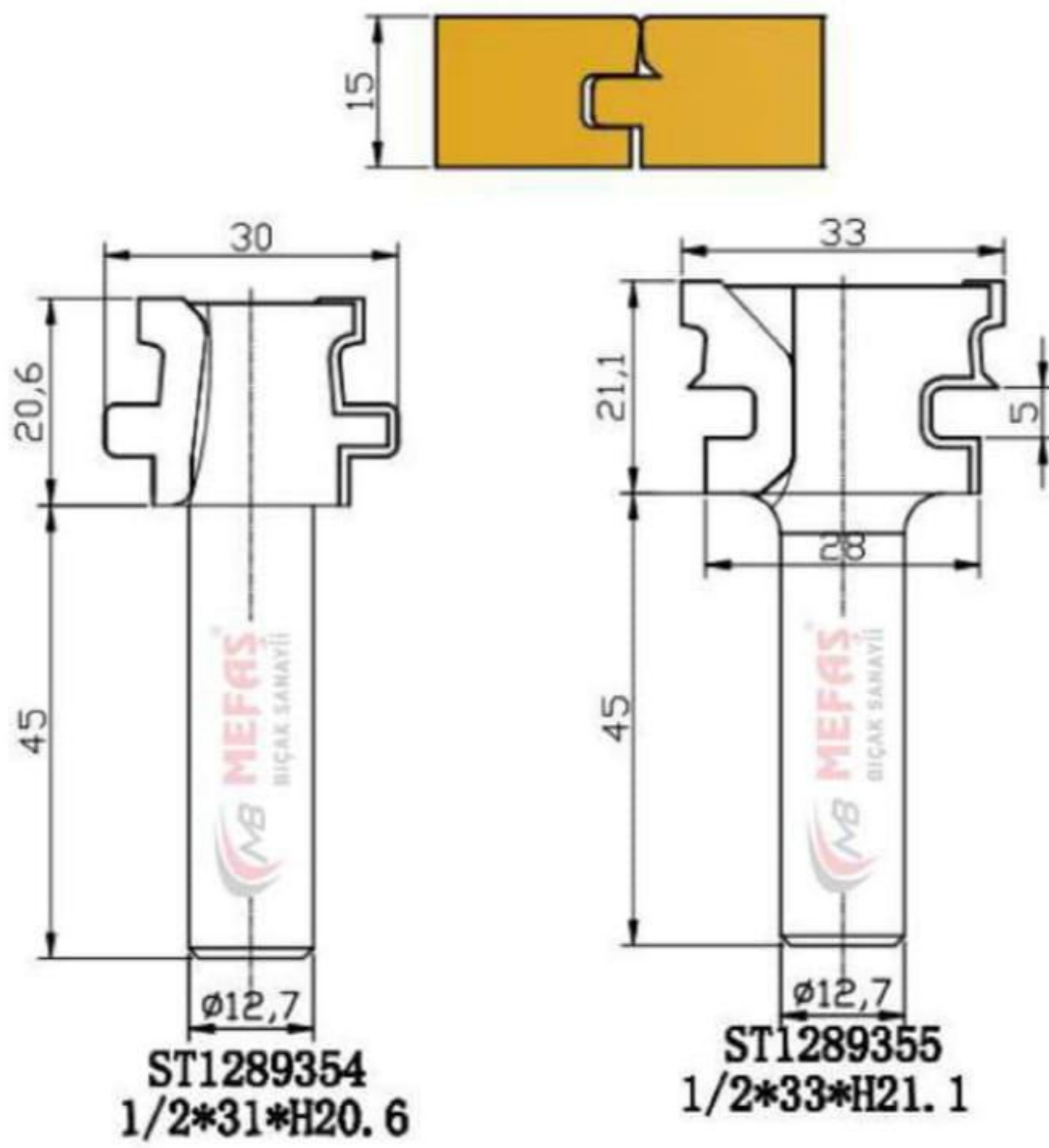
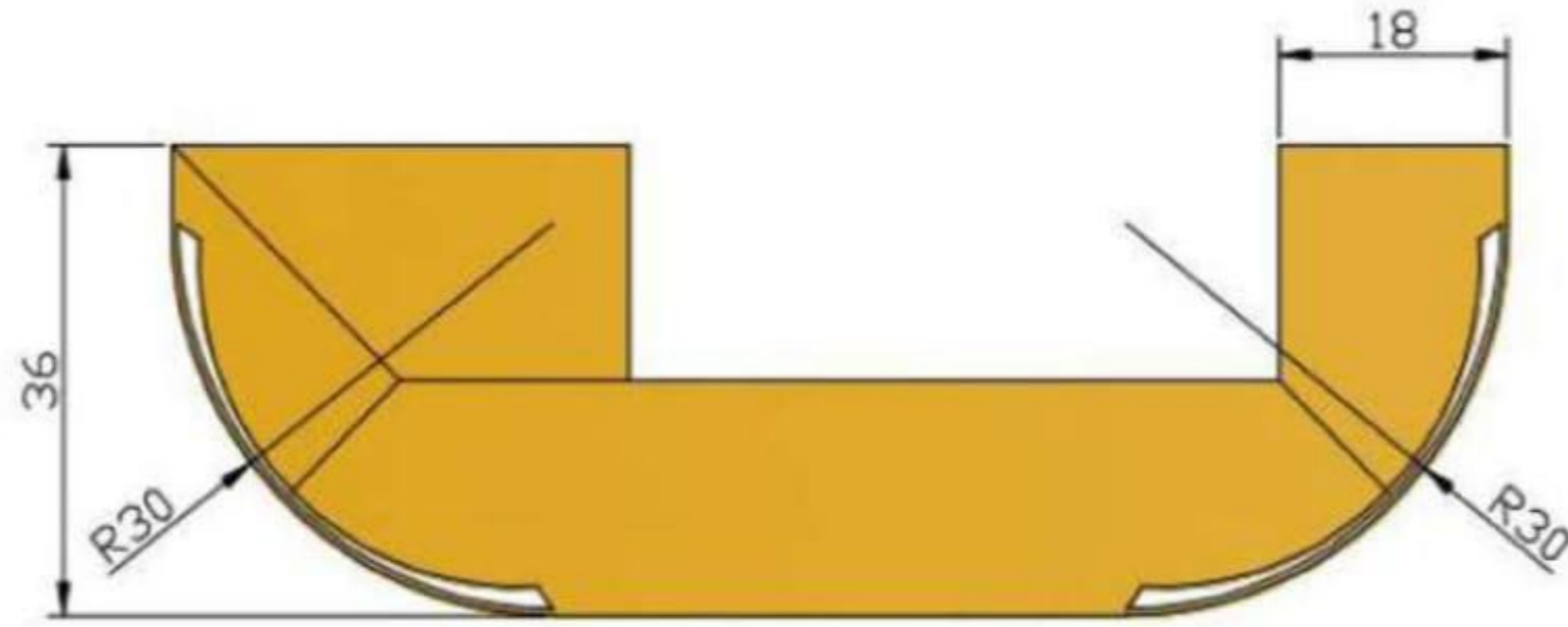
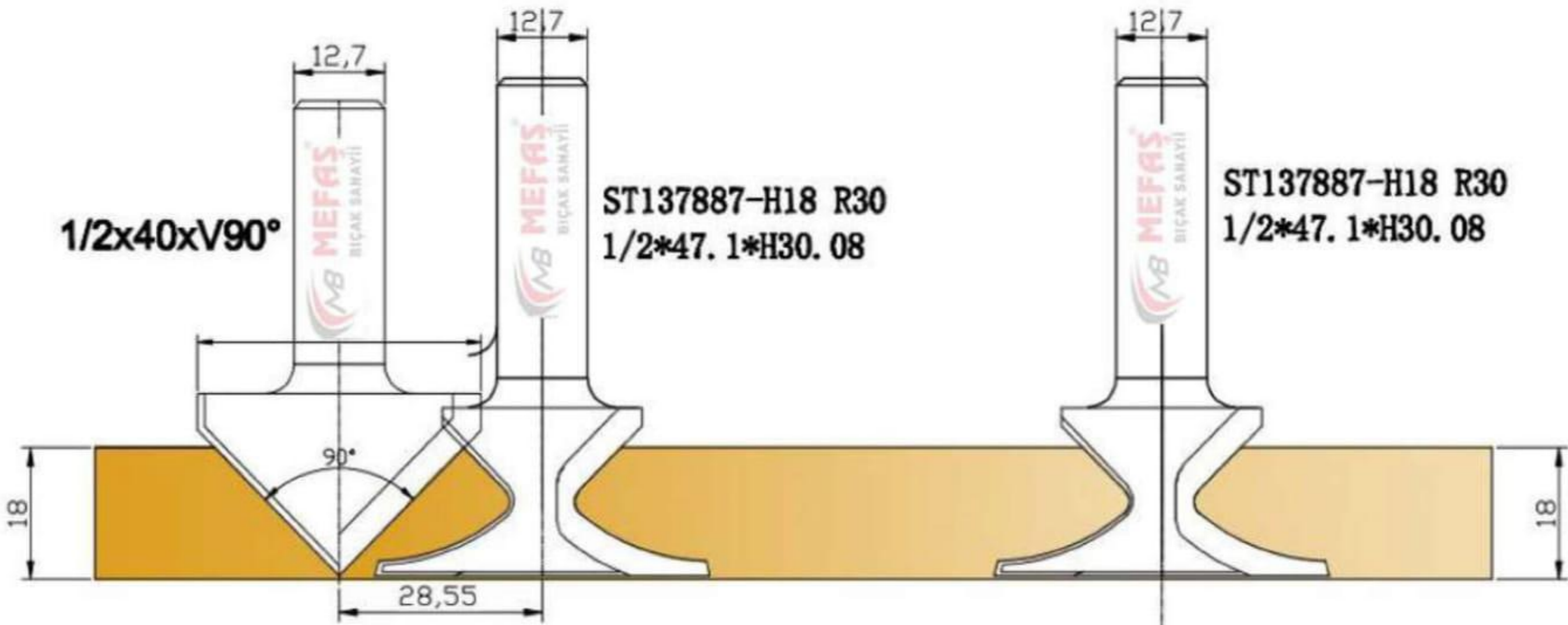

SPC, PVC,

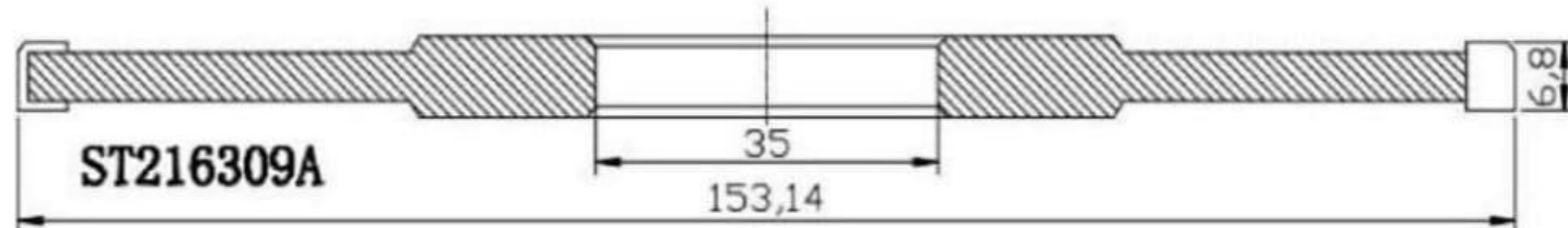
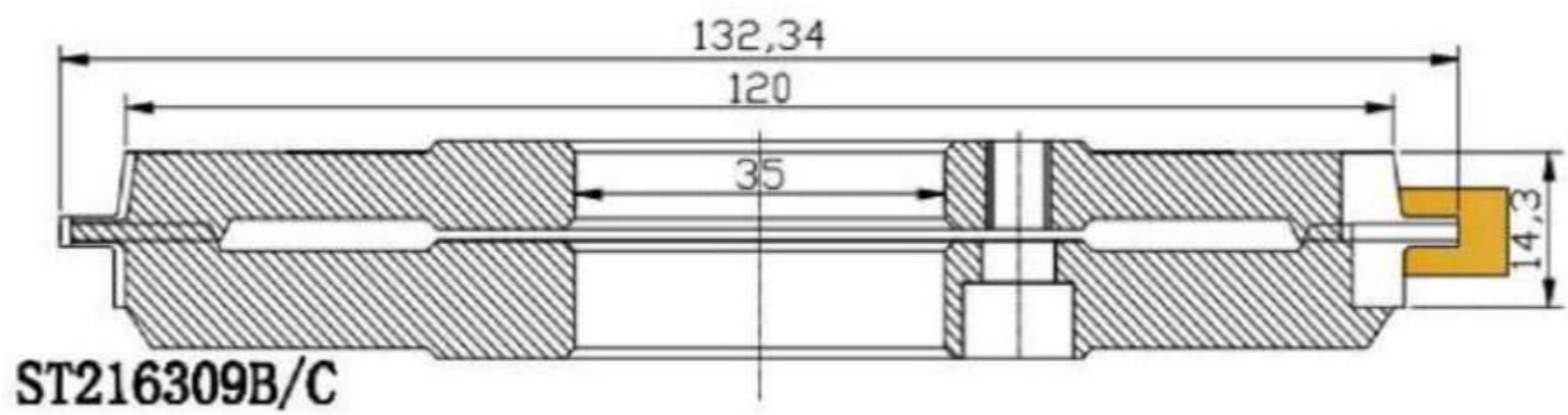
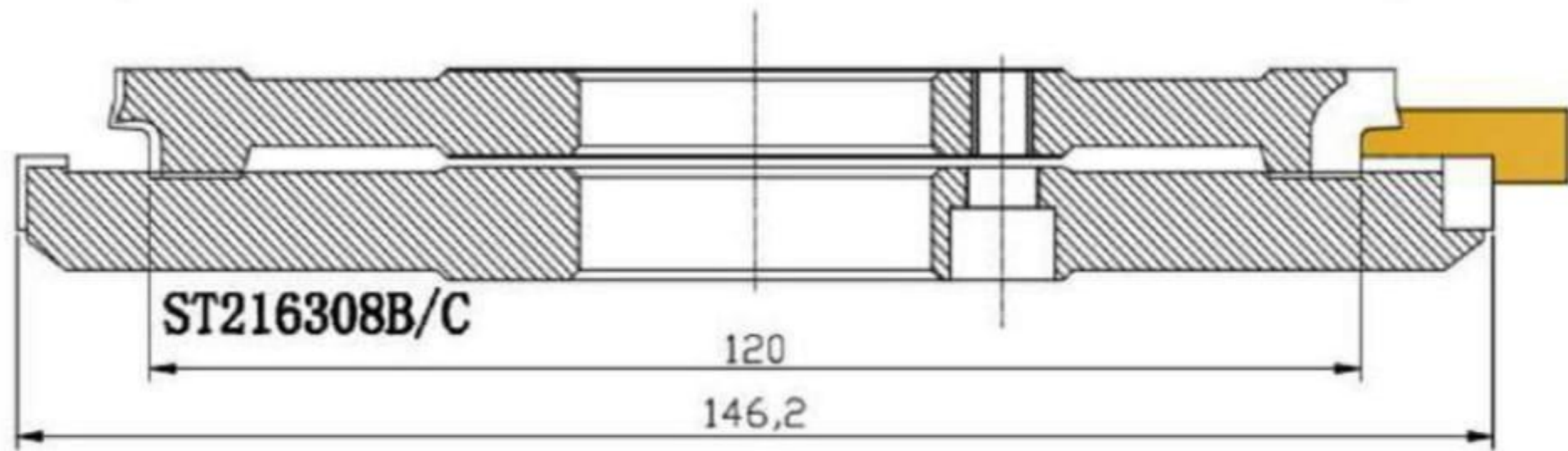
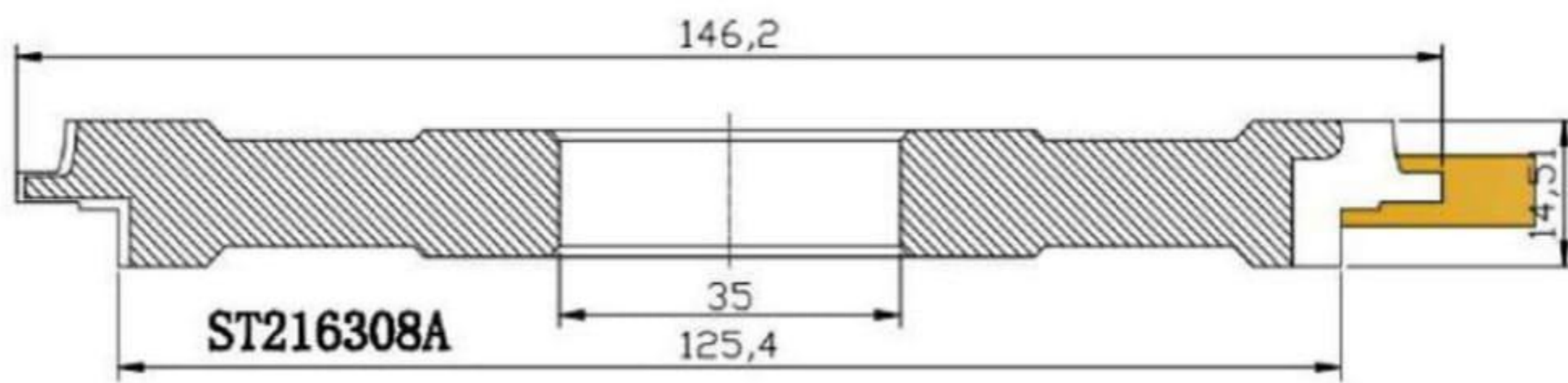
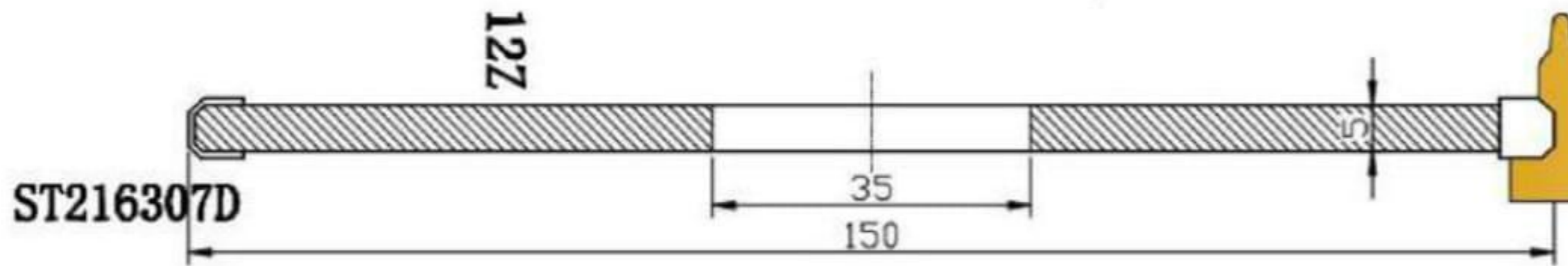
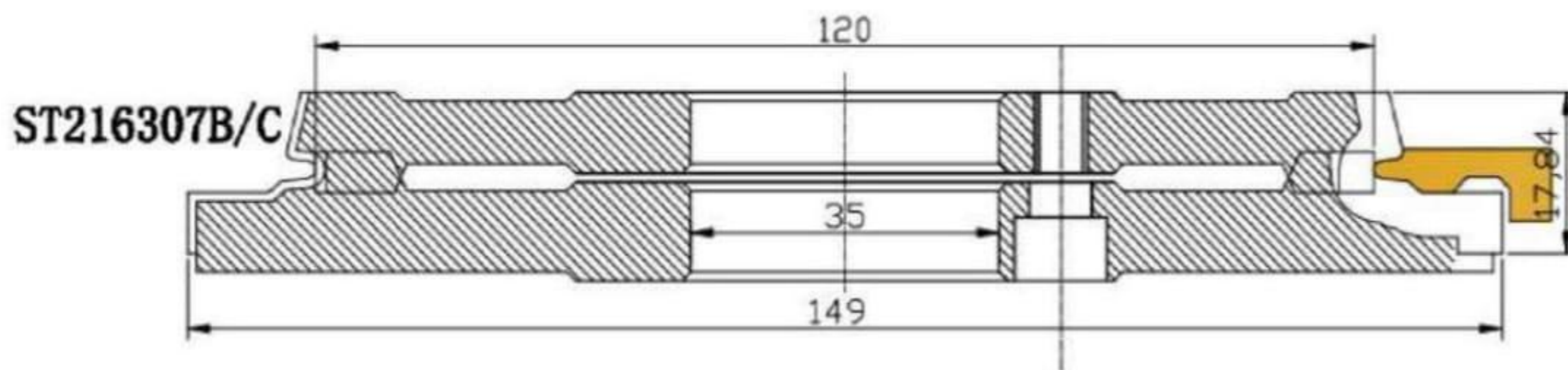
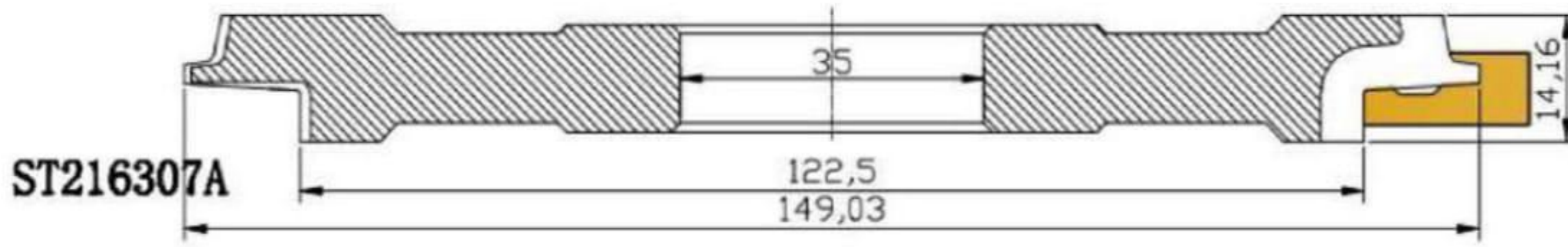

THE DIAMOND CLIP BALDE INSERTS CBN SERIES MACHINES

Elmas Sıkmalı Takım Uçları Serisi CBN Inserts

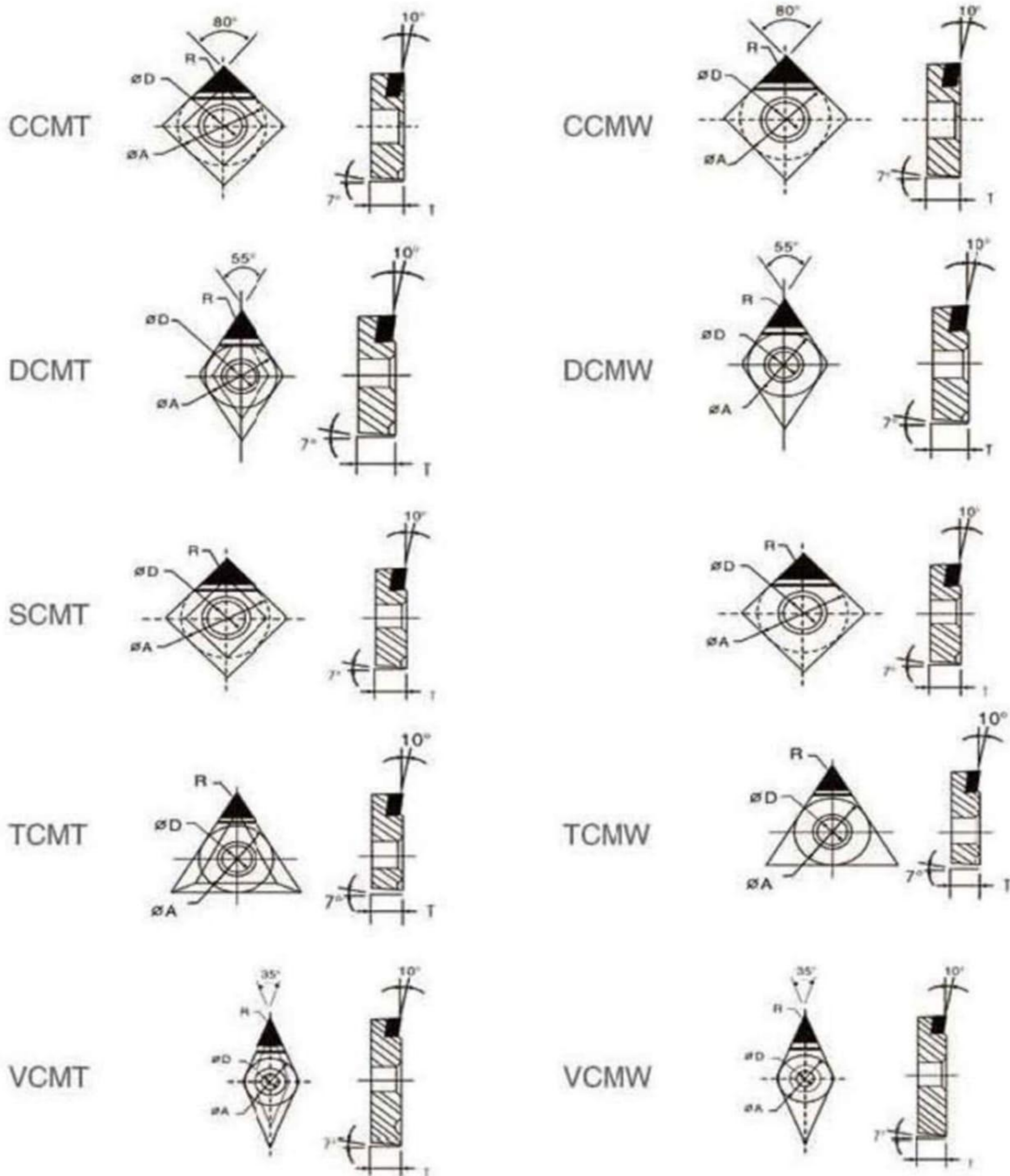

TAILOR-MADE PROFILE CUTTERS

Top Dia (PCD) ve Elmas Profil Bıçakları

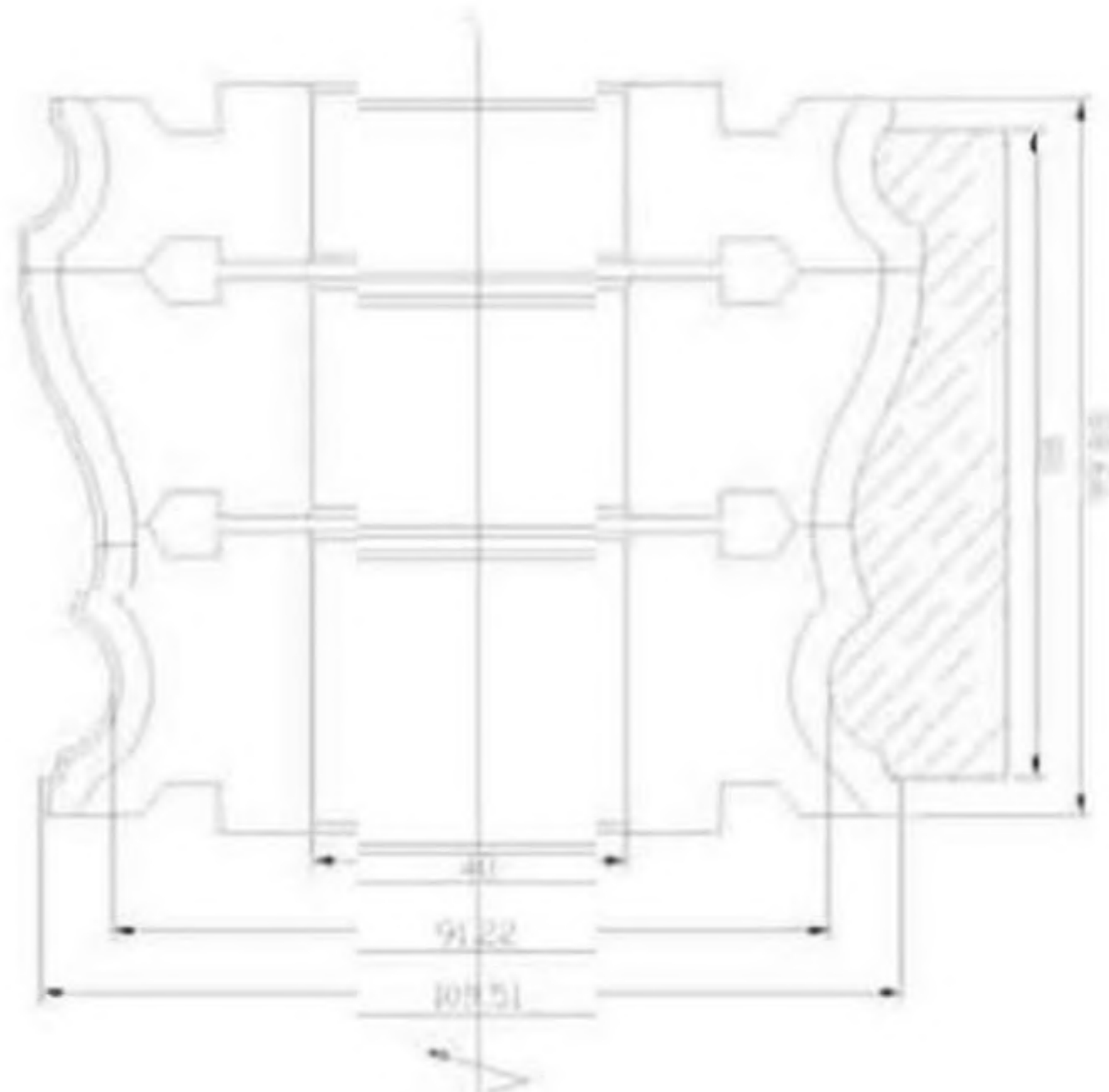

DIAMOND JOINTING CUTTERS FOR FLOOR

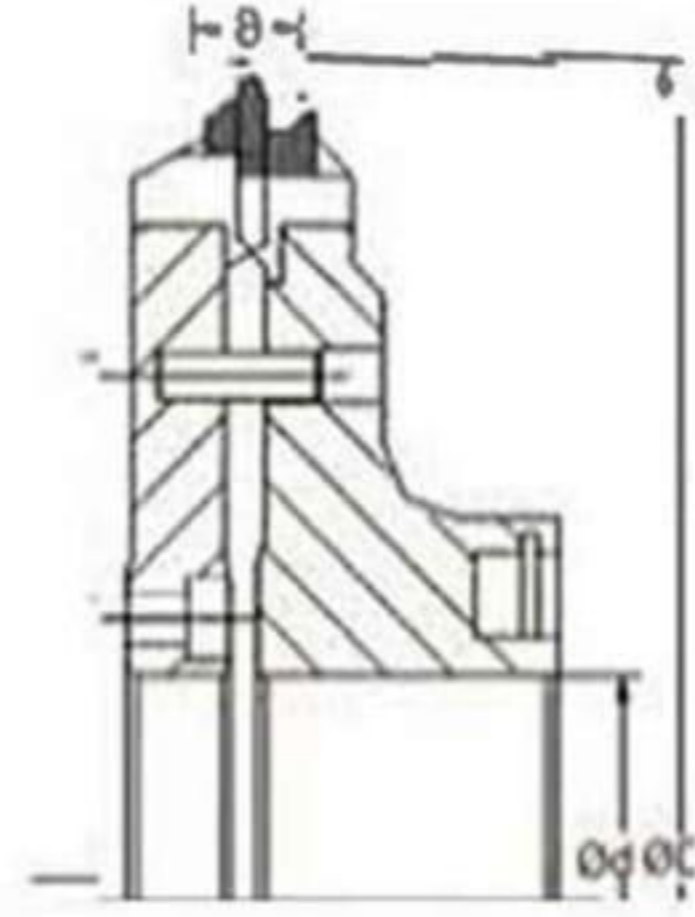

Part NO.	ØD	Ød	B	Z
SI005501	125	40	25	6+6+6
ST005502	130	40	25	6+6+6
ST005503	160	40	18	4+4
ST005504	160	40	18	6+6
ST005505	220	60	18	8+8
ST005506	220	60	18	10+10
ST005507	250	60	18	10+10
ST005508	250	60	18	12+12
ST005509	285	60	18	12+12

V SCORING CUTTER

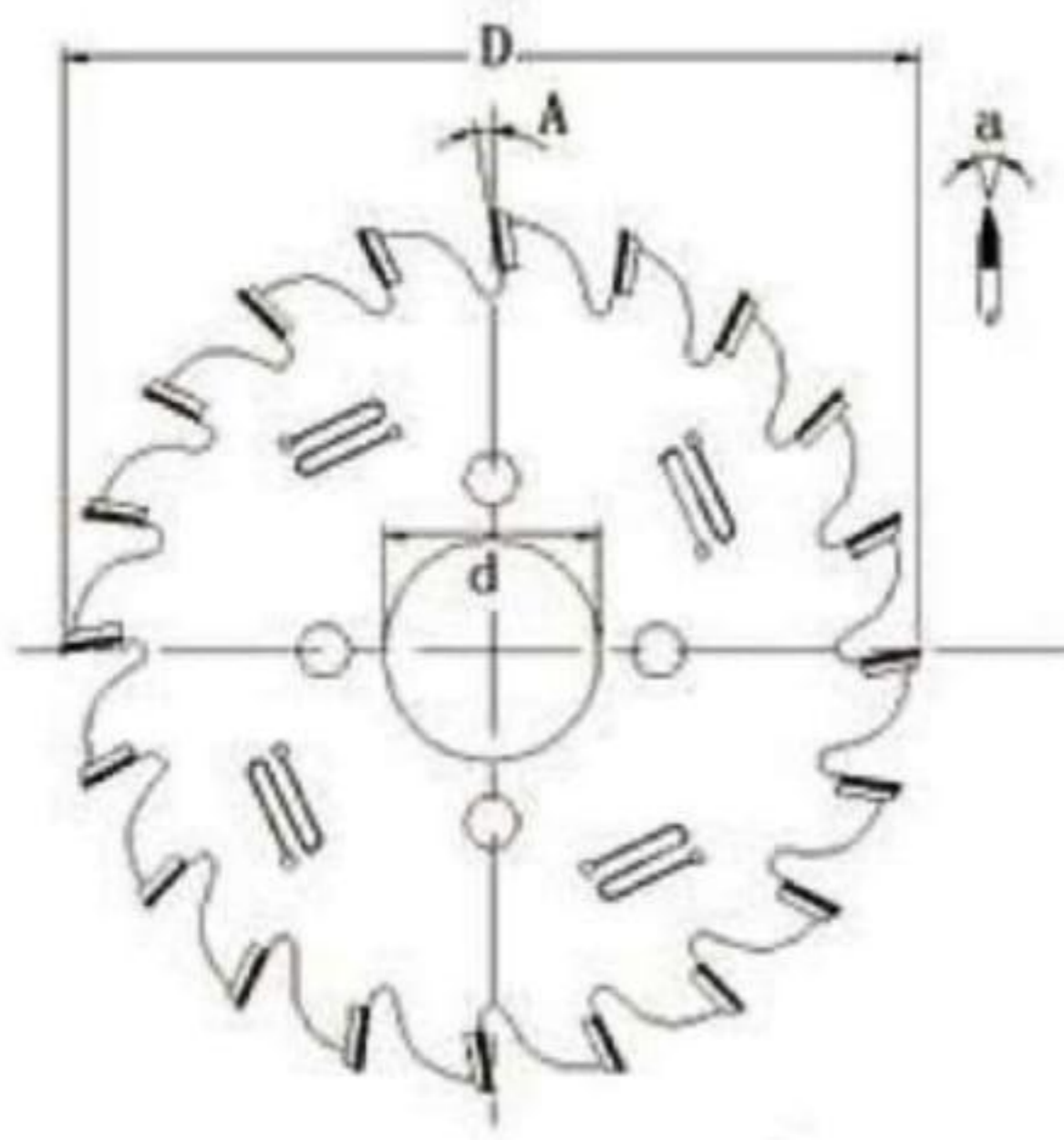

Part NO.	$\varnothing D$	$\varnothing d$	B	Z	a°
ST002101	120	25.4	2	20	30/35/45/60/120
ST002102	120	25.4	2	22	30/35/45/60/120
ST002103	120	25.4	2	24	30/45
ST002104	120	25.4	2	30	30/45
ST002105	100	25.4	2	20/24	30/35/45/60/120
ST002106	100	40	2	20/24	30/35/45/60/120

GROOVE AND TONGUE JOINT CUTTERS

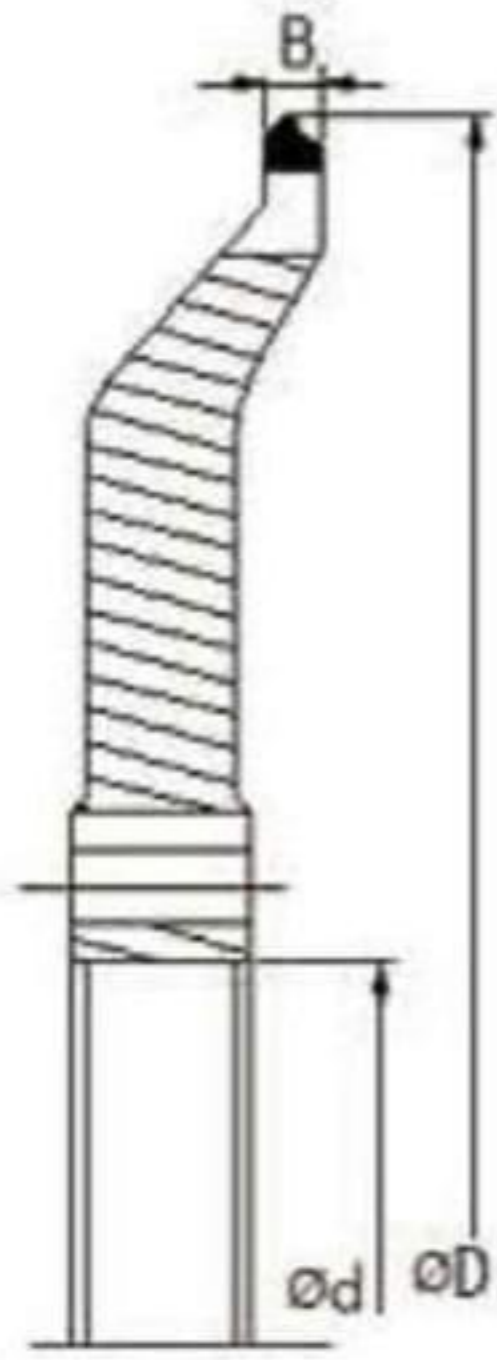

Part NO.	ØD	Ød	B	Z
ST005401	180	40	7	8
ST005402	180	60	7	12
ST005403	220	60	7	12
ST005404	220	60	7	16
ST005405	250	60	7	12
ST005406	250	60	7	16

DIAMOND SCORING CUTTER FOR FLOOR

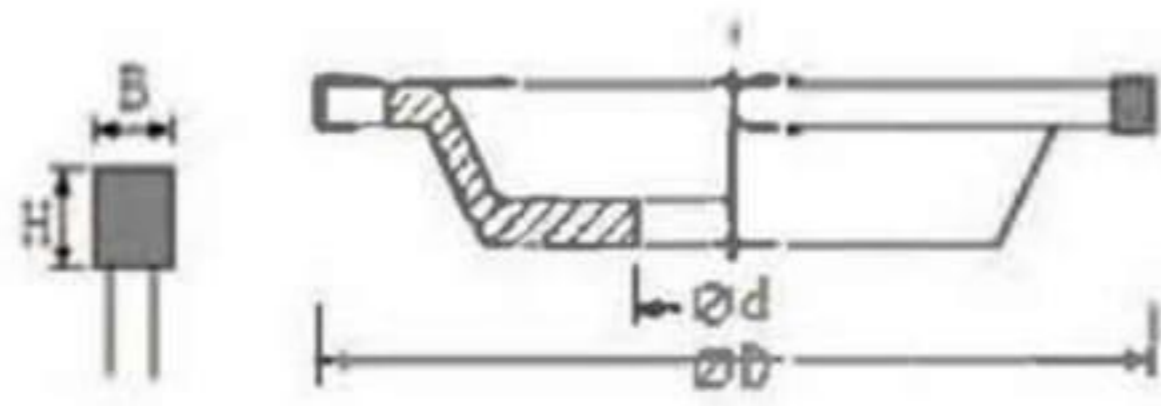

A#



B#

Part NO.	ØD	Ød	B	H	Z
ST005301	150	30/35/40	3.5/5/6/8	5	12/18/24
ST005302	160	30/35/40	3.5/5/6/8	5	12/18/24
ST005303	170	30/35/40	3.5/5/6/8	5	12/18/24
ST005304	180	30/35/40	3.5/5/6/8	5	12/18/24

DIAMOND RAISING CUTTER FOR FLOOR

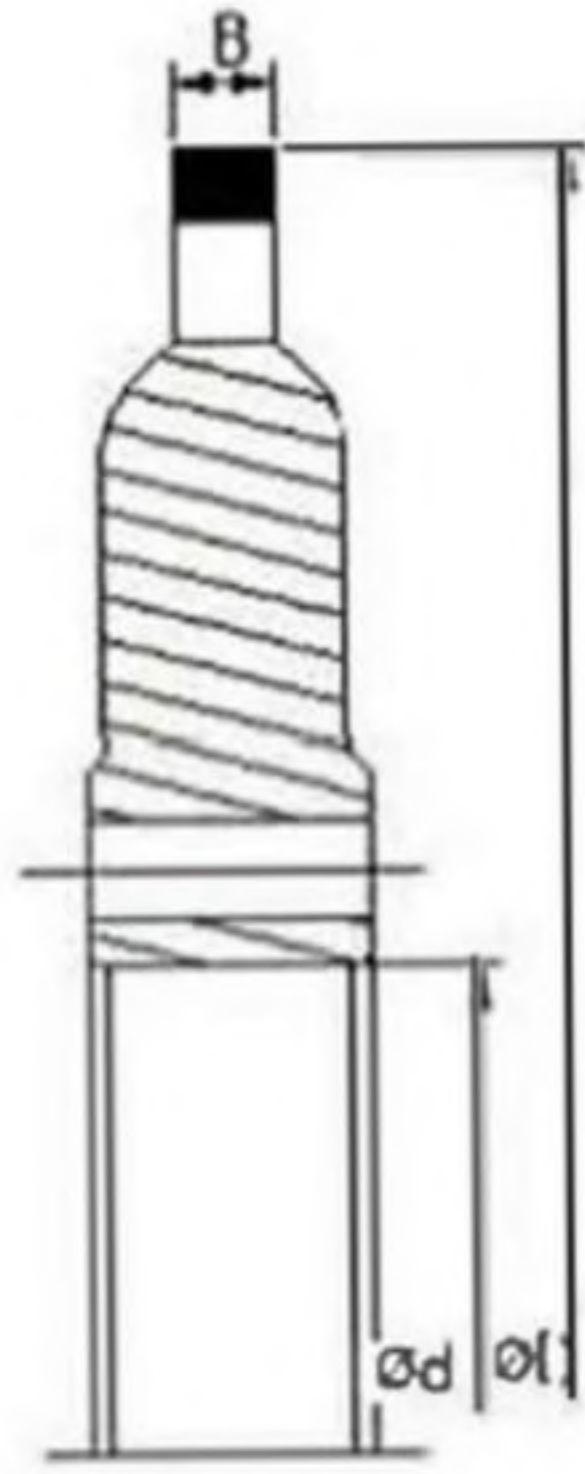

Part NO.	ØD	Ød	B	Z
ST005101	160	40	7	12
ST005102	160	40	4.5	12
ST005103	220	60	7	36
ST005104	220	60	4.5	36
ST005105	250	60	7	36
ST005106	250	60	4.5	36
ST005107	285	60	10	36

DIAMOND RAISING CUTTER FOR FLOOR

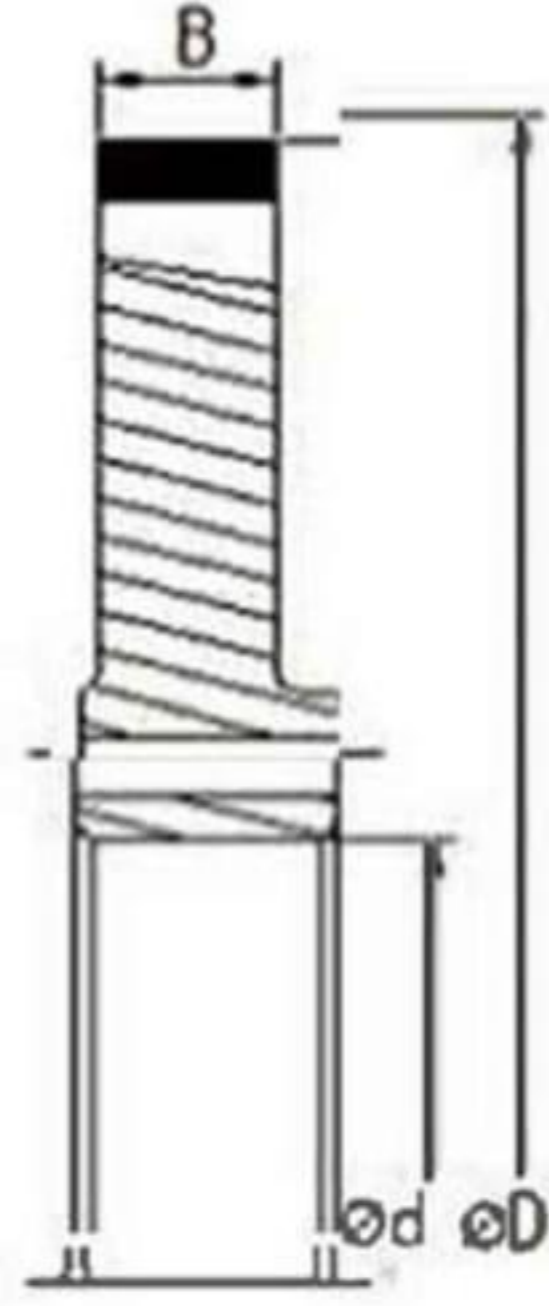

Part NO.	ØD	Ød	B	Z
ST005201	160	40	20	16
ST005202	180	40	7+5	12+6
ST005203	180	40	7+5	12+8
ST005204	220	60	7	24
ST005205	250	60	15/8	24+12
ST005206	250	60	15/8	36+12

THE WHOLE STRUCTURE PCBN(PCD)

PCD (PCBN) Tam Yapılı Takımlar

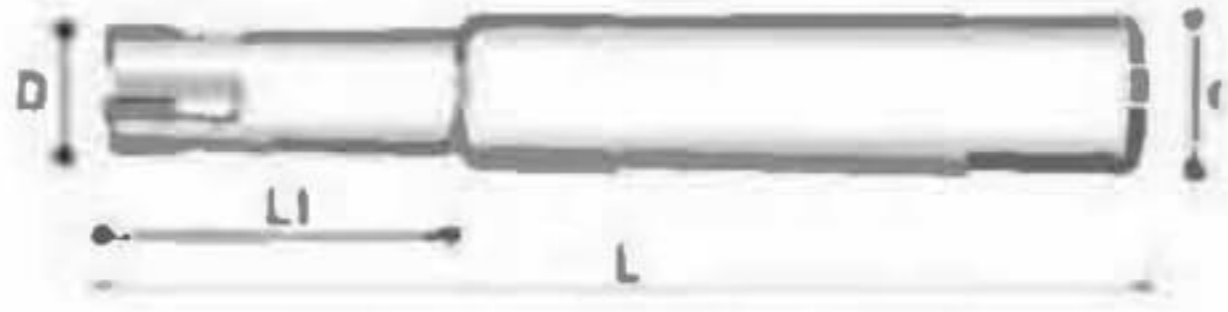

Freze Biçağı

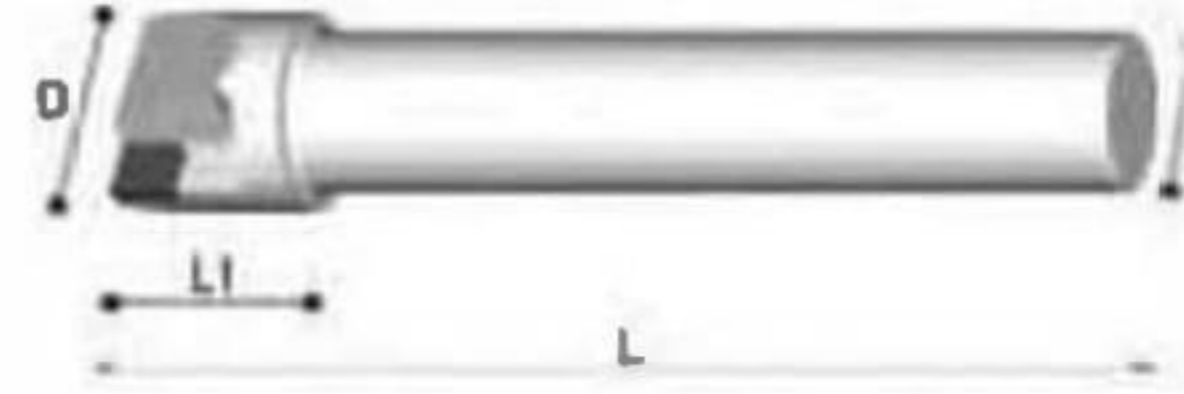

Freze Biçağı

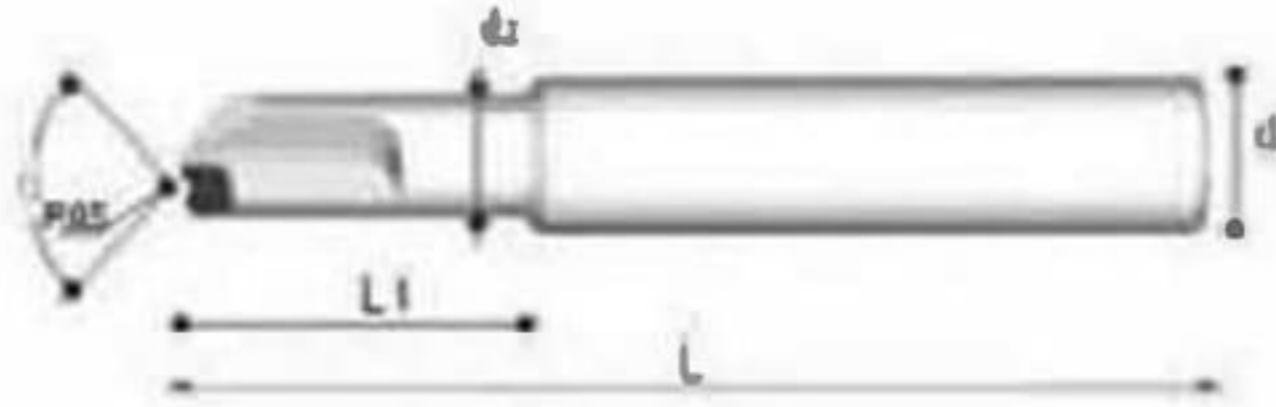

V Şekilli Biçak



Profil Tornalama Biçağı



Gravür/Markalama Biçağı

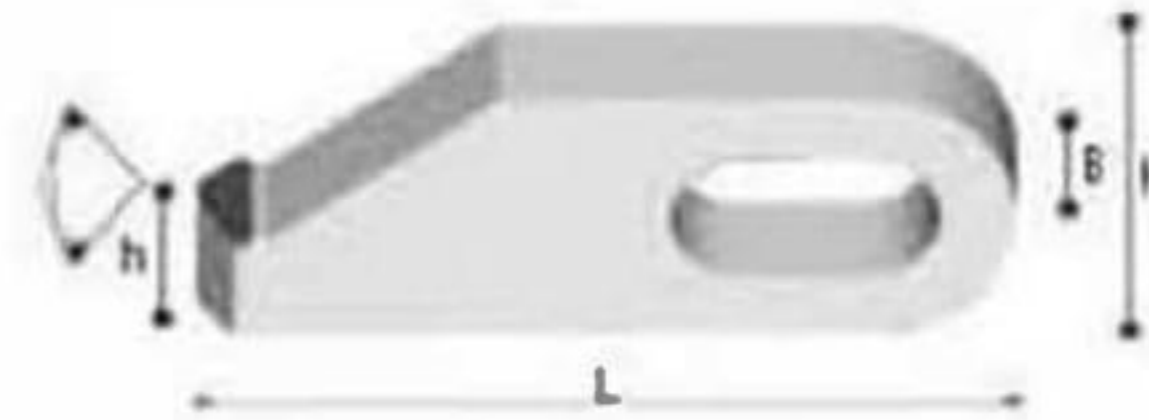

Gravür/Markalama Biçağı



Kesme Biçağı



Vida Tornalama Biçağı

Köşe dişli freze ucu				
NO NO	Sap Çapı SHK	Biçak Çapı CED	Biçak Uzunluk CEL	Toplam Uzunluk OVL
10080403	3.175	0.4	3	38
10080503	3.175	0.5	3	38
10080604	3.175	0.6	4	38
10080704	3.175	0.7	4	38
10080805	3.175	0.8	5	38
10080906	3.175	0.9	6	38
10081007	3.175	1	7	38
10081207	3.175	1.2	7	38
10081408	3.175	1.4	8	38
10081508	3.175	1.5	8	38
10081809	3.175	1.8	9	38
10082010	3.175	2	10	38
10082512	3.175	2.5	12	38
10083012	3.175	3	12	38
10083112	3.175	3.175	12	38
10083115	3.175	3.175	15	38
10083117	3.175	3.175	17	38
10083122	3.175	3.175	22	45
10083125	3.175	3.175	25	45
10084012	4	4	12	45
10084015	4	4	15	45
10084017	4	4	17	45
10084022	4	4	22	45
10084025	4	4	25	50
10084028	4	4	28	50
10084032	4	4	32	55
10086017	6	6	17	50
10086022	6	6	22	50
10086025	6	6	25	50
10086028	6	6	28	60
10086032	6	6	32	60
10086042	6	6	42	75
10086052	6	6	52	85
10086062	6	6	62	100
10088025	8	8	25	60
10088032	8	8	32	60
10088035	8	8	35	75
10088042	8	8	42	75
10088052	8	8	52	90
10081042	10	10	42	75
10081052	10	10	52	100
10081242	12	12	42	75
10081255	12	12	55	100

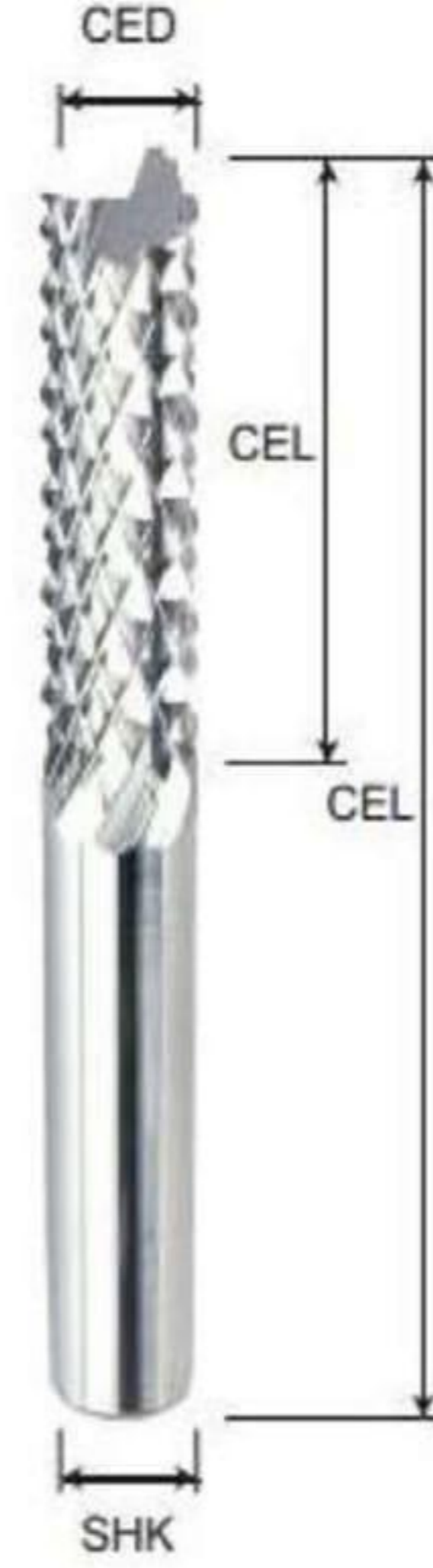

Akrilik/ağşap tek ağızlı freze ucu				
NO	Sap Çapı	Biçak Çapı	Biçak Uzunluk	Toplam Uzunluk
NO	SHK	CED	CEL	OVL
10060104	3.175	1	4	38
10061507	3.175	1.5	7	38
10061512	3.175	1.5	12	38
10060208	3.175	2	8	38
10060212	3.175	2	12	38
10060215	3.175	2	15	38
10060217	3.175	2	17	38
10060222	3.175	2	22	45
10062508	3.175	2.5	8	38
10062512	3.175	2.5	12	38
10062515	3.175	2.5	15	38
10062517	3.175	2.5	17	38
10062522	3.175	2.5	22	45
10063112	3.175	3.175	12	38
10063115	3.175	3.175	15	38
10063117	3.175	3.175	17	38
10063122	3.175	3.175	22	45
10063125	3.175	3.175	25	50
10063132	3.175	3.175	32	55
10063142	3.175	3.175	42	70
10063152	3.175	3.175	52	75
10060415	4	4	15	45
10060422	4	4	22	45
10060425	4	4	25	50
10060428	4	4	28	50
10060432	4	4	32	55
10060442	4	4	42	70
10060452	4	4	52	75
10060525	5	5	25	50
10060528	5	5	28	55
10060532	5	5	32	60
10060625	6	6	25	50
10060628	6	6	28	60
10060632	6	6	32	60
10060642	6	6	42	75
10060652	6	6	52	85
10060662	6	6	62	100
10060825	8	8	25	60
10060832	8	8	32	60
10060842	8	8	42	75
10060852	8	8	52	85
10060862	8	8	62	100
10061032	10	10	32	75
10061042	10	10	42	85
10061052	10	10	52	100
10061062	10	10	62	120
10061232	12	12	32	75
10061242	12	12	42	85
10061252	12	12	52	100
10061262	12	12	62	120

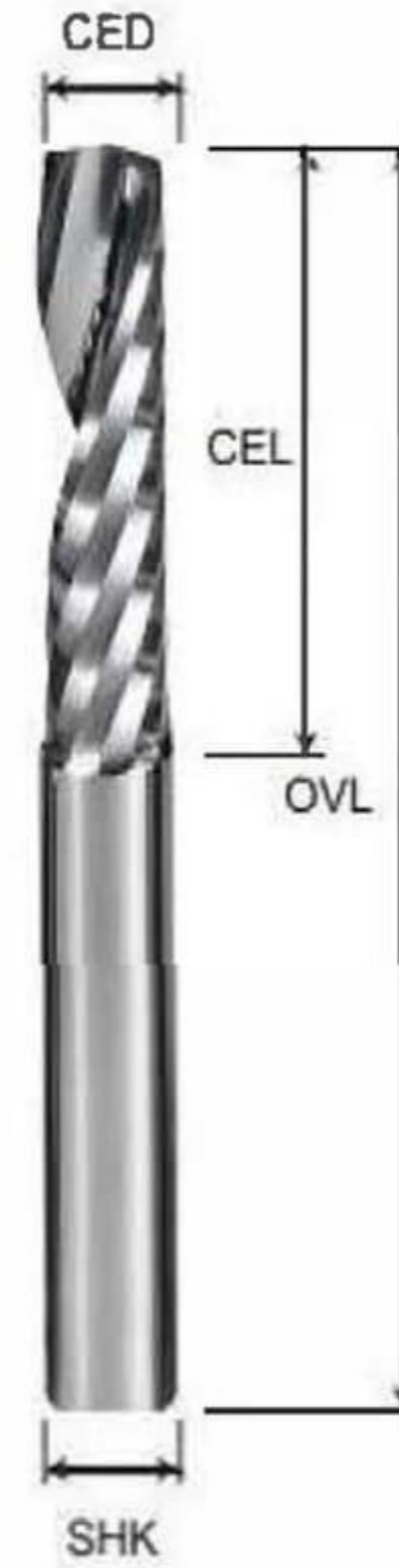

Akrilik/Ahşap Tek Ağızlı Biçak (Aşağı Kesim)

NO	Sap Çapı	Biçak Çapı	Biçak Uzunluk	Toplam Uzunluk
NO	SHK	CED	CEL	OVL
10473103	3.175	1	3	38
104731504	3.175	1.5	4	38
104731507	3.175	1.5	7	38
104731512	3.175	1.5	12	38
10473026	3.175	2	6	38
10473028	3.175	2	8	38
10473212	3.175	2	12	38
10473215	3.175	2	15	38
10473217	3.175	2	17	38
10473206	3.175	2.5	6	38
10473258	3.175	2.5	8	38
104732512	3.175	2.5	12	38
104732517	3.175	2.5	17	38
10473108	3.175	3.175	8	38
10473112	3.175	3.175	12	42
10473115	3.175	3.175	15	45
10473117	3.175	3.175	17	50
10473122	3.175	3.175	22	50
10473125	3.175	3.175	25	50
10473128	3.175	3.175	28	50
10473132	3.175	3.175	32	55
10470412	4	4	12	45
10470417	4	4	17	45
10470422	4	4	22	50
10470425	4	4	25	55
10470428	4	4	28	60
10470432	4	4	32	65
10470517	5	5	17	50
10470522	5	5	22	50
10470525	5	5	25	55
10470528	5	5	28	60
10470532	5	5	32	65
10470617	6	6	17	50
10470622	6	6	22	55
10470625	6	6	25	60
10470628	6	6	28	60
10470632	6	6	32	65
1470642	6	6	42	75
10470825	8	8	25	65
10470832	8	8	32	70
10470842	8	8	42	80

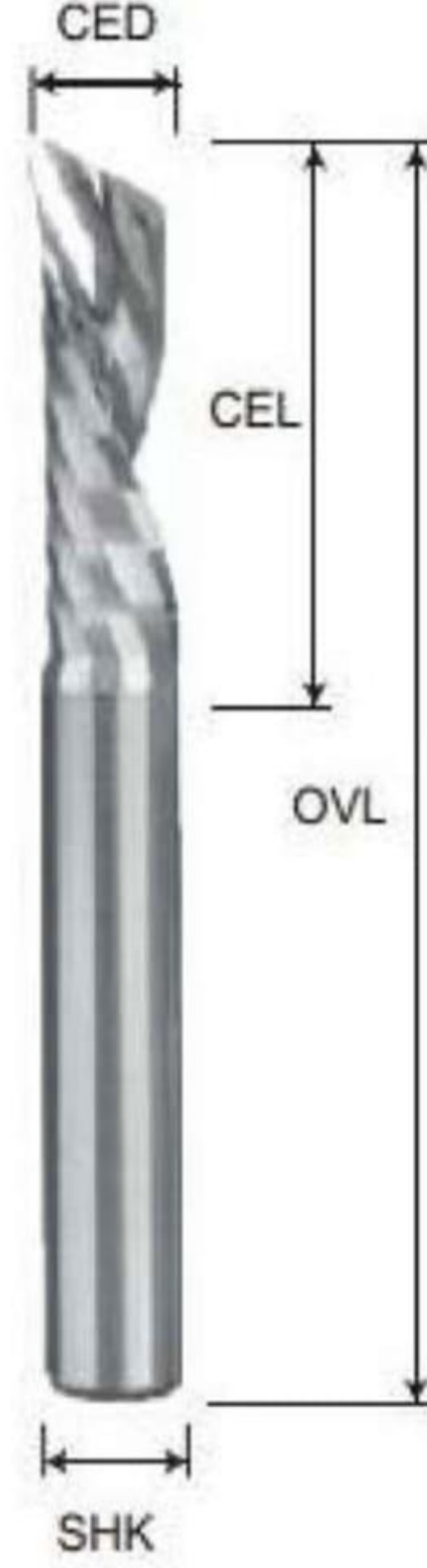

Tek ağızlı alüminyum bıçağı For aluminum				
NO NO	Sap Çapı SHK	Bıçak Çapı CED	Bıçak Uzunluk CEL	Toplam Uzunluk OVL
10153013	3.175	1	3	38
10153155	3.175	1.5	5	38
10153024	3.175	2	4	38
10153026	3.175	2	6	38
10083028	3.175	2	8	38
10153254	3.175	2.5	4	38
10153256	3.175	2.5	6	38
10153258	3.175	2.5	8	38
10153117	3.175	3.175	8	38
10153117	3.175	3.175	10	38
10153112	3.175	3.175	12	38
10153117	3.175	3.175	17	38
10150410	4	4	10	45
10150412	4	4	12	45
10150415	4	4	15	45
10150417	4	4	17	45
10150422	4	4	22	45
10150617	6	6	17	45
10150622	6	6	22	50
10150822	8	8	22	60
10150825	8	8	25	60
10151025	10	10	25	75
10151032	10	10	32	75
10151042	10	10	42	85
10151235	12	12	35	75
10151242	12	12	42	80

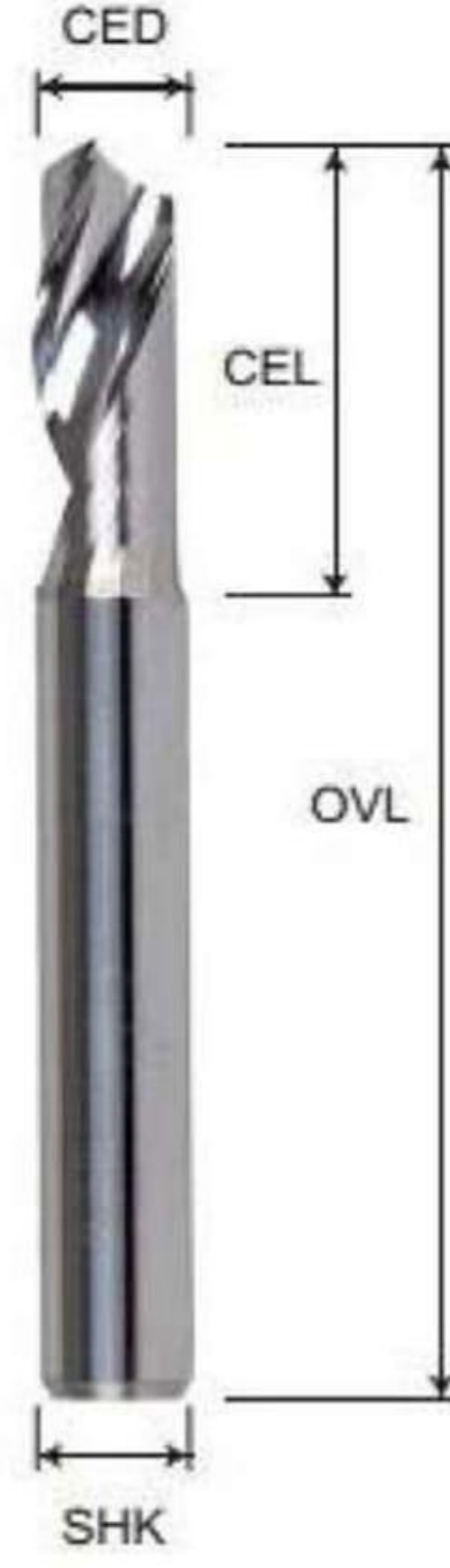

İki ağızlı ahşap işleme bıçağı

WOODWORKING STRAIGHT MILLING CUTTERS Z2 POSITIVE

Smooth and clean surface. Suitable for CNC engraving light wood, splint, solid wood, particle board, multiply laminate, MDF etc.

NO NO	Sap Çapı SHK	Bıçak Çapı CED	Bıçak Uzunluk CEL	Toplam Uzunluk OVL
10200130	3.175	1	3	38
10201507	3.175	1.5	7	38
10201512	3.175	1.5	12	38
10200212	3.175	2	12	38
10200217	3.175	2	17	38
10200222	3.175	2	22	38
10202512	3.175	2.5	12	38
10202517	3.175	2.5	17	38
10202522	3.175	2.5	22	45
10203117	3.175	3.175	17	38
10203125	3.175	3.175	25	50
10203132	3.175	3.175	32	55
10200412	4	4	12	45
10200417	4	4	17	45
10200425	4	4	25	50
10200432	4	4	32	55
10200442	4	4	42	65
10200625	6	6	25	50
10200632	6	6	32	60
10200642	6	6	42	70
10200652	6	6	52	80
10200662	6	6	62	100
10200825	8	8	25	60
10200832	8	8	32	60
10200842	8	8	42	80
10200852	8	8	52	90
10200862	8	8	62	100
10201032	10	10	32	75
10201042	10	10	42	80
10201052	10	10	52	100
10201062	10	10	62	110
10201232	12	12	32	75
10201242	12	12	42	80
10201252	12	12	52	100
10201262	12	12	62	110
10201280	12	12	80	120
10201274	12.7	12.7	42	90
10201275	12.7	12.7	52	100
10201276	12.7	12.7	62	110
10201278	12.7	12.7	80	120
10201642	16	16	42	90
10201652	16	16	52	100
10201662	16	16	62	110
10201672	16	16	72	120
10201852	18	18	52	100
10201872	18	18	72	120
10202052	20	20	52	100
10202062	20	20	62	110
10202072	20	20	72	120

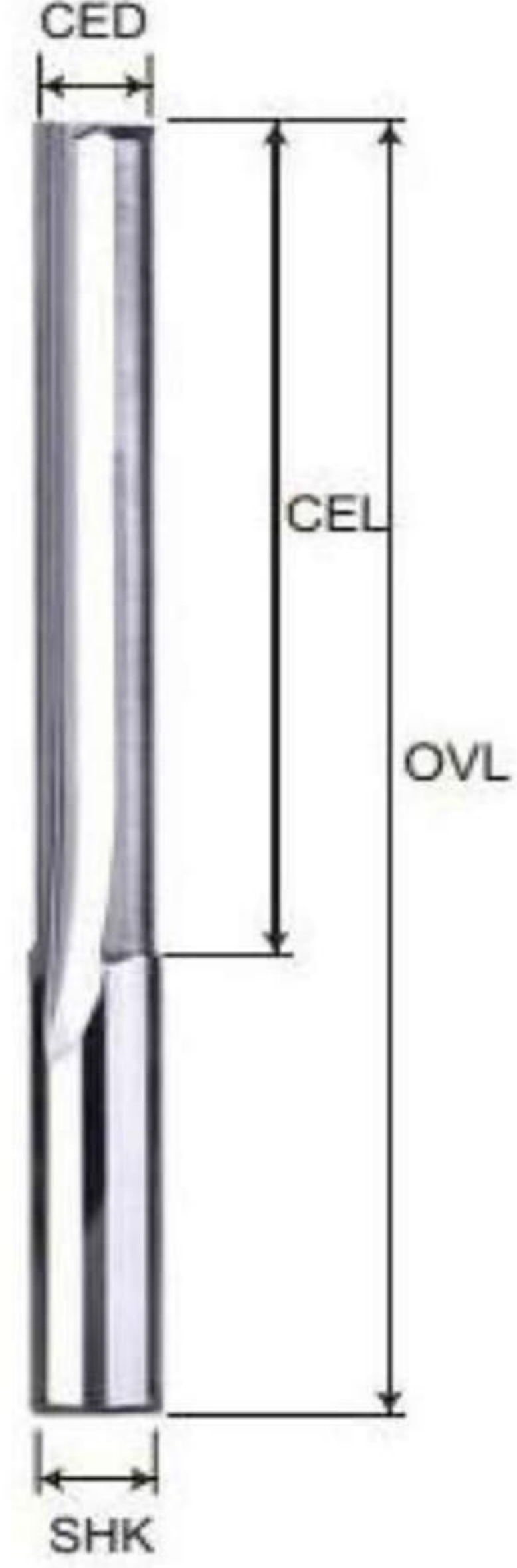

İki ağızlı ahşap işleme küre bıçağı

WOODWORKING BALLNOSE FINISHING MILLING CUTTERS Z2

Suitable for working hard wood, light wood, solid wood, particle board, laminate, MDF/HDF and polymers etc.

NO NO	Sap Çapı SHK	Bıçak Çapı CED	Bıçak Uzunluk CEL	Toplam Uzunluk OVL
10170104	3.175	1	4	38
10171506	3.175	1.5	7	38
10170212	3.175	2	12	38
10170222	3.175	2	22	45
10172512	3.175	2.5	12	38
10172522	3.175	2.5	22	45
10173112	3.175	3.175	12	38
10173125	3.175	3.175	25	45
10173132	3.175	3.175	32	55
10170408	4	4	8	45
10170417	4	4	17	45
10170425	4	4	25	50
10170432	4	4	32	55
10170442	4	4	42	70
10170452	4	4	52	80
10170625	6	6	25	50
10170632	6	6	32	60
10170642	6	6	42	70
10170652	6	6	52	80
10170825	8	8	25	60
10170832	8	8	32	60
10170842	8	8	42	80
10170852	8	8	52	90
10171032	10	10	32	70
10171042	10	10	42	80
10171052	10	10	52	100
10171062	10	10	62	110
10171232	12	12	32	70
10171242	12	12	42	80
10171252	12	12	52	100
10171262	12	12	62	110
10171280	12	12	80	120
10171274	12.7	12.7	42	90
10171275	12.7	12.7	52	100
10171276	12.7	12.7	62	110
10171278	12.7	12.7	80	120
10171442	14	14	42	90
10171452	14	14	52	100
10171642	16	16	42	90
10171652	16	16	52	100
10171662	16	16	62	110
10171672	16	16	72	120
10172052	20	20	52	100
10172062	20	20	62	110
10172072	20	20	72	120

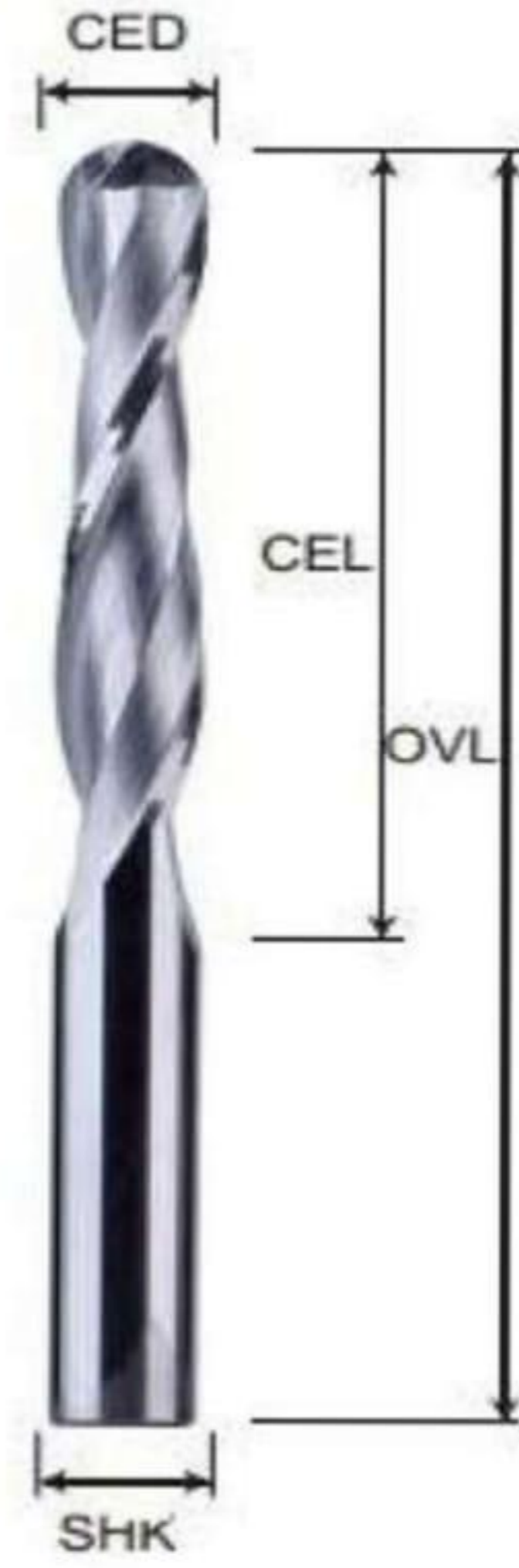

iki ağızlı ahşap işleme bıçağı

WOODWORKING FINISHING MILLING CUTTERS Z2 POSITIVE

Suitable for working hard wood, light wood, solid wood, particle board, laminate, MDF/HDF and polymers etc.

NO	Sap Çapı	Bıçak Çapı	Bıçak Uzunluk	Toplam Uzunluk
NO	SHK	CED	CEL	OVL
10110104	3.175	1	4	38
10111508	3.175	1.5	8	38
10111512	3.175	1.5	12	38
10110212	3.175	2	12	38
10110222	3.175	2	22	45
10112512	3.175	2.5	12	38
10112522	3.175	2.5	22	45
10113115	3.175	3.175	15	38
10113125	3.175	3.175	25	45
10113132	3.175	3.175	32	50
10113142	3.175	3.175	42	65
10113152	3.175	3.175	52	75
10110417	4	4	17	45
10110425	4	4	25	50
10110432	4	4	32	55
10110442	4	4	42	70
10110452	4	4	52	80
10110517	5	5	17	45
10110525	5	5	25	50
10110532	5	5	32	60
10110625	6	6	25	50
10110628	6	6	28	60
10110632	6	6	32	60
10110642	6	6	42	70
10110652	6	6	52	80
10110662	6	6	62	100
10110825	8	8	25	60
10110832	8	8	32	60
10110842	8	8	42	80
10110852	8	8	52	90
10111032	10	10	32	70
10111042	10	10	42	80
10111052	10	10	52	100
10111062	10	10	62	110
10111230	12	12	32	70
10111242	12	12	42	80
10111250	12	12	52	100
10111262	12	12	62	110
10111280	12	12	80	120
10111274	12.7	12.7	42	90
10111275	12.7	12.7	52	100
10111276	12.7	12.7	62	110
10111278	12.7	12.7	80	120
10111642	16	16	42	90
10111652	16	16	52	100
10111662	16	16	62	110
10111672	16	16	72	120
10112052	20	20	52	100
10112062	20	20	62	110
10112072	20	20	72	120

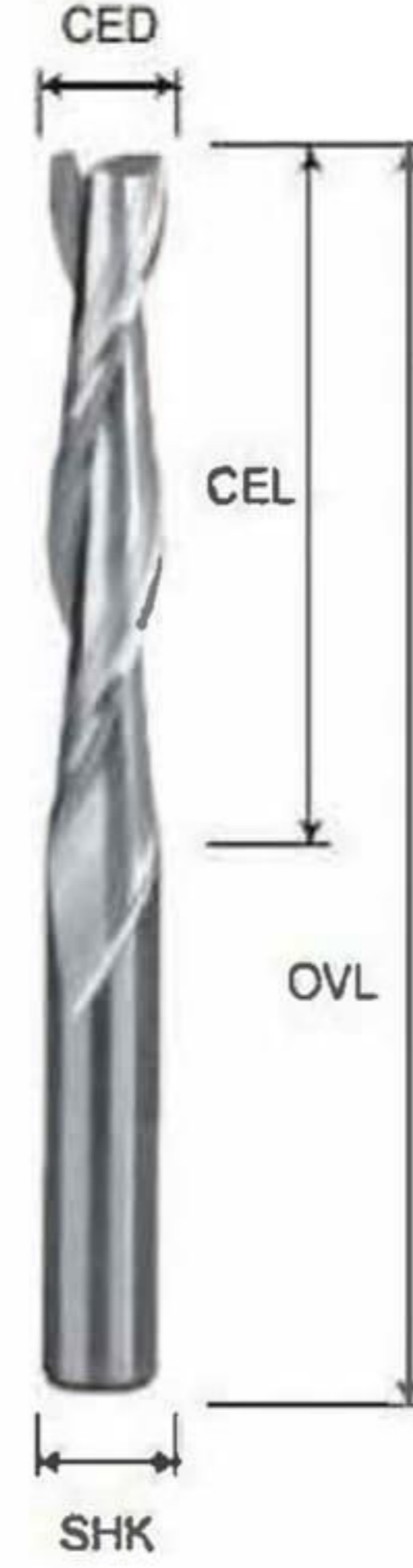

Üç ağızlı ahşap işleme bıçağı

WOODWORKING FINISHING MILLING CUTTERS Z3 POSITIVE

Fast processing speed, easy discharge, high surface finishing and lower processing noise. It is suitable for cutting multi-layer board,

NO NO	Sap Çapı SHK	Bıçak Çapı CED	Bıçak Uzunluk CEL	Toplam Uzunluk OVL
10130625	6	6	25	50
10130628	6	6	32	60
10130652	6	6	40	80
10130662	6	6	50	100
10130832	8	8	30	60
10130842	8	8	35	75
10130852	8	8	42	80
1013850	8	8	50	100
10131032	10	10	32	70
10131035	10	10	35	75
10131042	10	10	42	90
10131052	10	10	52	100
10131062	10	10	62	110
10131235	12	12	35	75
10131250	12	12	50	100
10131260	12	12	60	110
10131270	12	12	70	120
10131274	12.7	12.7	42	90
10131275	12.7	12.7	50	100
10131276	12.7	12.7	60	110
10131277	12.7	12.7	70	120
10131278	12.7	12.7	80	130
10131442	14	14	42	90
10131452	14	14	52	100
10131462	14	14	62	110
10131472	14	14	72	120
10131642	16	16	42	90
10131652	16	16	52	100
10131662	16	16	62	110
10131672	16	16	72	120
10131690	16	16	90	150
10131852	18	18	52	100
10131862	18	18	62	110
10131872	18	18	72	120
101318102	18	18	102	150
10132052	20	20	52	100
10132062	20	20	62	110
10132072	20	20	72	120
10132085	20	20	85	140
101320102	20	20	102	150
10132080	20	12.7	80	120
10132280	22	12.7	80	120

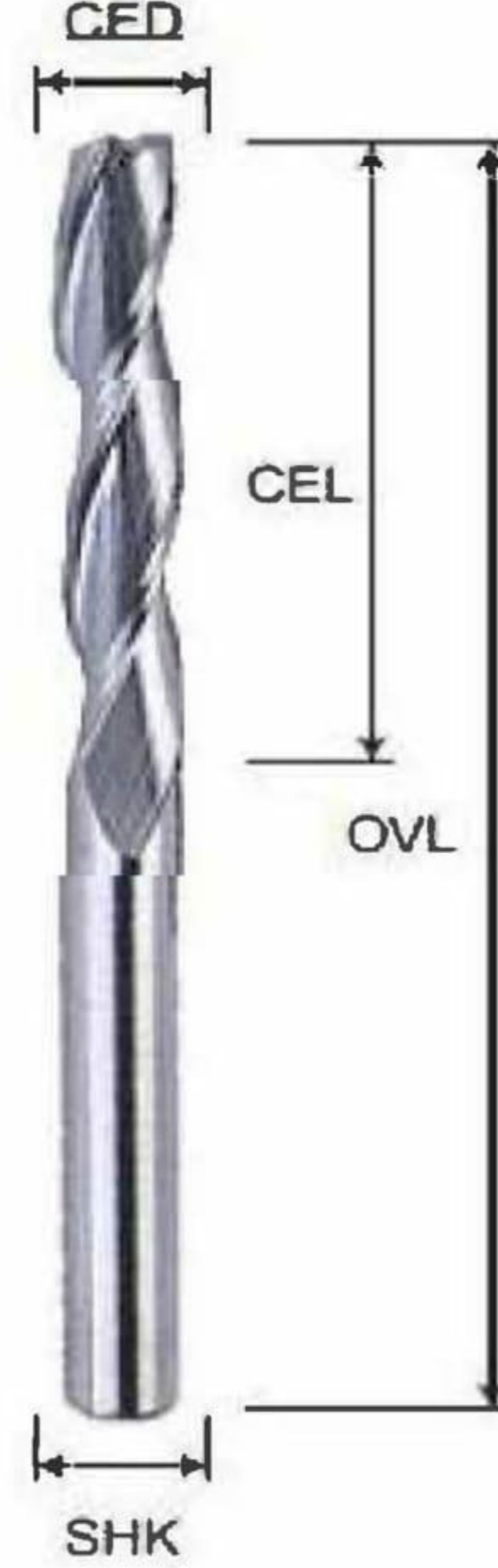

3Z Üç Ağızlı Ahşap İşleme Dalgalı Kesici (Tam Dalgalı Kesici)
WOODWORKING ROUGHING MILLING CUTTERS Z3 POSITIVE

Suitable for drilling the lockhole of wooden door, cutting the slot of hardwoods, particle board, laminate etc.

NO	Sap Çapı SHK	Bıçak Çapı CED	Bıçak Uzunluk CEL	Toplam Uzunluk OVL
10300625	6	6	25	60
10300632	6	6	32	70
10300635	6	6	35	75
10300642	6	6	42	80
10300650	6	6	50	100
10300825	8	8	25	60
10300832	8	8	32	70
10300835	8	8	35	75
10300845	8	8	42	80
10300850	8	8	55	100
10301035	10	10	35	75
10301045	10	10	45	90
10301050	10	10	52	100
10301235	12	12	35	75
10301250	12	12	52	100
10301255	12	12	60	110
10301270	12	12	70	120
10301280	12	12	80	130
103012100	12	12	100	150
10301273	12.7	12.7	35	75
10301275	12.7	12.7	52	100
10301276	12.7	12.7	60	110
10301277	12.7	12.7	70	120
10301278	12.7	12.7	80	130
10301271	12.7	12.7	100	150
10301452	14	14	52	100
10301455	14	14	60	110
10301475	14	14	70	120
10301655	16	16	52	100
10301662	16	16	62	110
10301675	16	16	72	120
10301682	16	16	82	130
103016100	16	16	100	150
10301845	18	18	52	100
10301862	18	18	62	110
10301872	18	18	72	120
10301810	18	18	100	150
10302052	20	20	52	100
10302062	20	20	62	110
10302072	20	20	72	120
10302085	20	20	85	140
10302010	20	20	100	150

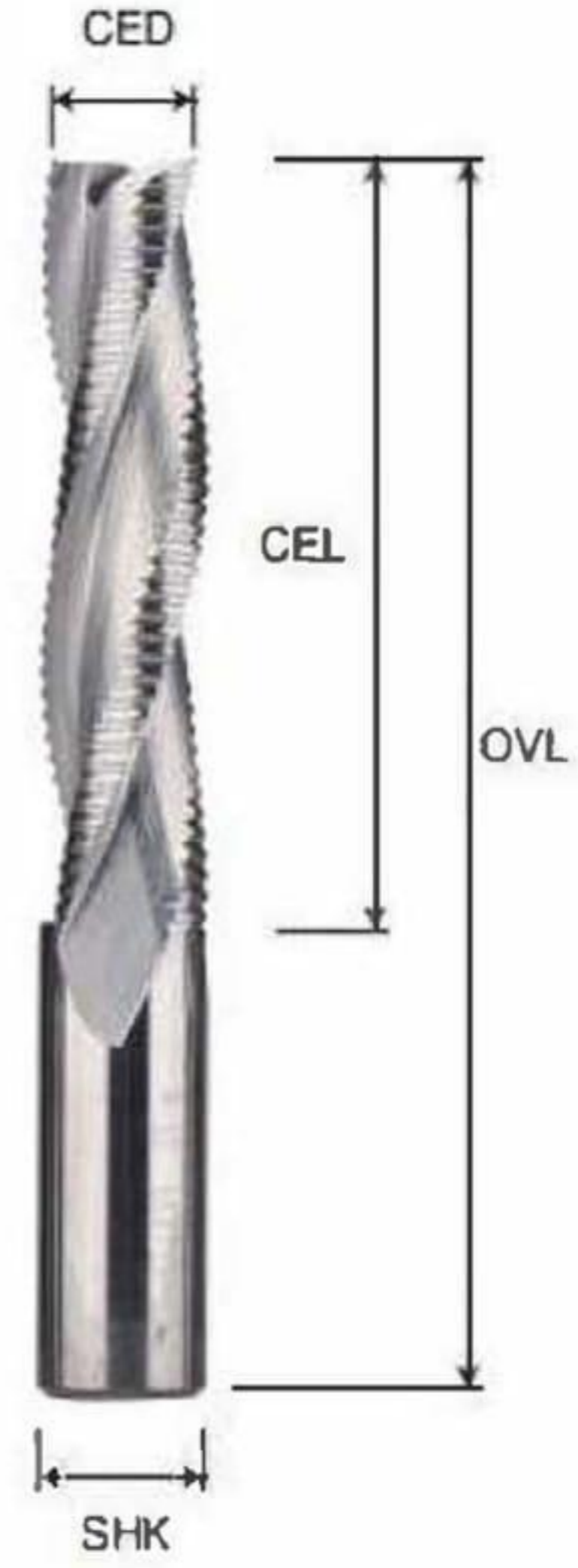

Üç Ağızlı Ahşap İşleme Dalgalı Kesici (Yarı Dalgalı Kesici)

NO NO	Bıçak Çapı CED	Bıçak Uzunluk CEL	Bıçak Uzunluk I	Sap Çapı SHK	Toplam Uzunluk OVL
107516105	16	105	55	16	165
107517105	17	105	55	16	165
107518105	18	105	55	16	165
107520105	20	105	55	16	165
107522105	22	105	55	16	165

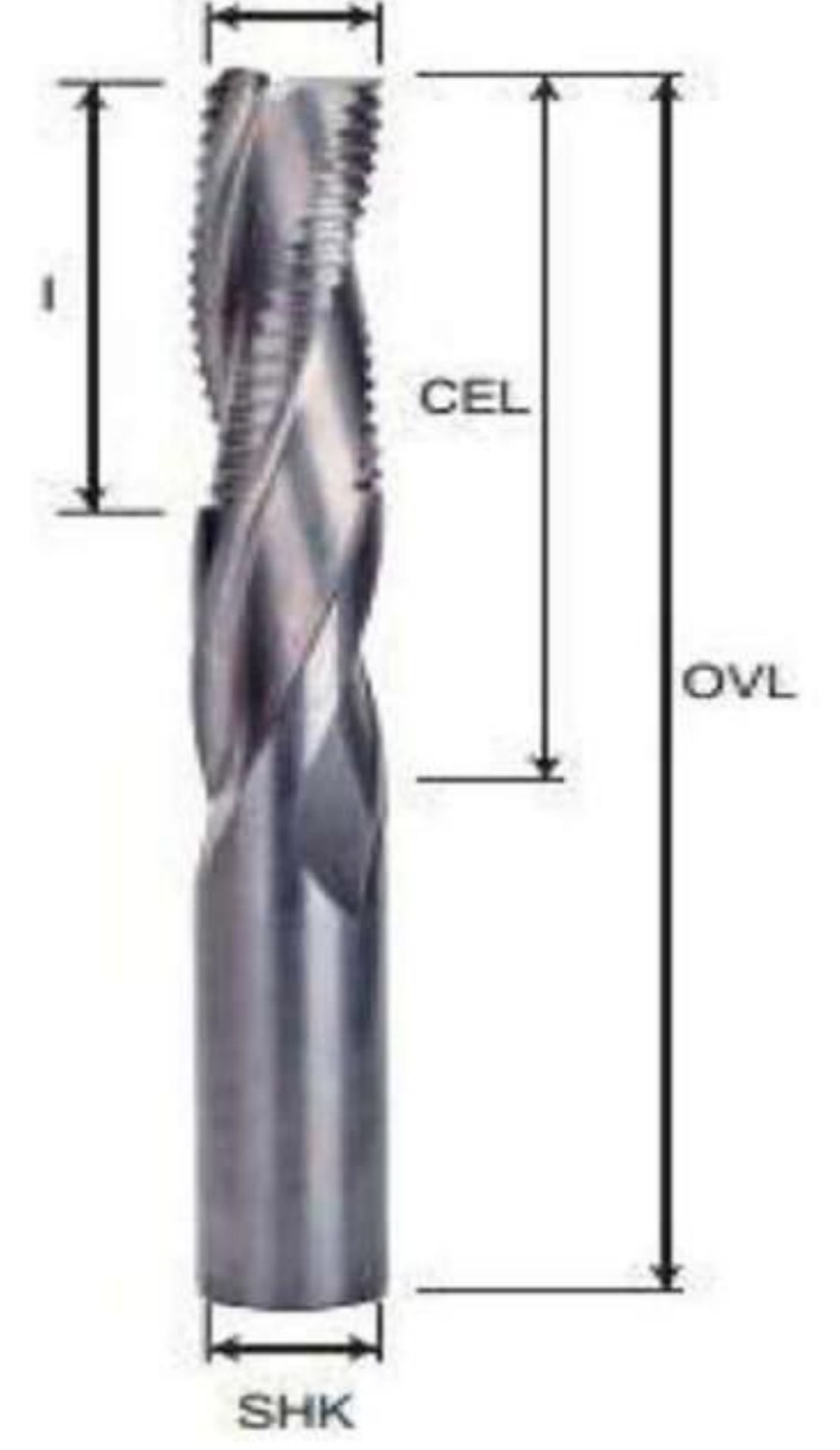

İki Ağızlı Ahşap İşleme Konik Küre Bıçağı (Kaplama)

NO NO	Sap Çapı SHK	Küre Ucu Yançapı 1/2	Bıçak Çapı CED	Bıçak Uzunluk CEL	Toplam Uzunluk OVL
102832538	3.175	0.25	0.5	15	38
102830538	3.175	0.5	1	15	38
102842550	4	0.25	0.5	15	50
102840550	4	0.5	1	15	50
102847550	4	0.75	1.5	15	50
102841050	4	1	2	15	50
102842520	4	0.25	0.5	20.5	50
102840520	4	0.5	1	20.5	50
102847520	4	0.75	1.5	20.5	50
102841020	4	1	2	20.5	50
102842575	4	0.25	0.5	20.5	75
102840575	4	0.5	1	20.5	75
102847575	4	0.75	1.5	20.5	75
102740175	4	1	2	20.5	75
102862550	6	0.25	0.5	20.5	50
102860550	6	0.5	1	20.5	50
102867550	6	0.75	1.5	20.5	50
102860150	6	1	2	20.5	50
102862575	6	0.25	0.5	30.5	75
102860575	6	0.5	1	30.5	75
102867575	6	0.75	1.5	30.5	75
102861075	6	1	2	30.5	75
102861575	6	1.5	3	30.5	75
102862075	6	2	4	30.5	75
102862010	6	2	4	60	100
102880585	8	0.5	1	47	85
102881085	8	1	2	47	85
102881585	8	1.5	3	47	85
102882085	8	2	4	47	85
102880510	8	0.5	1	60	100
102881010	8	1	2	60	100
102881510	8	1.5	3	60	100
102882010	8	2	4	60	100
102812011	10	2	4	70	110
102812212	12	2	4	70	120
102812115	12	1	2	100	150

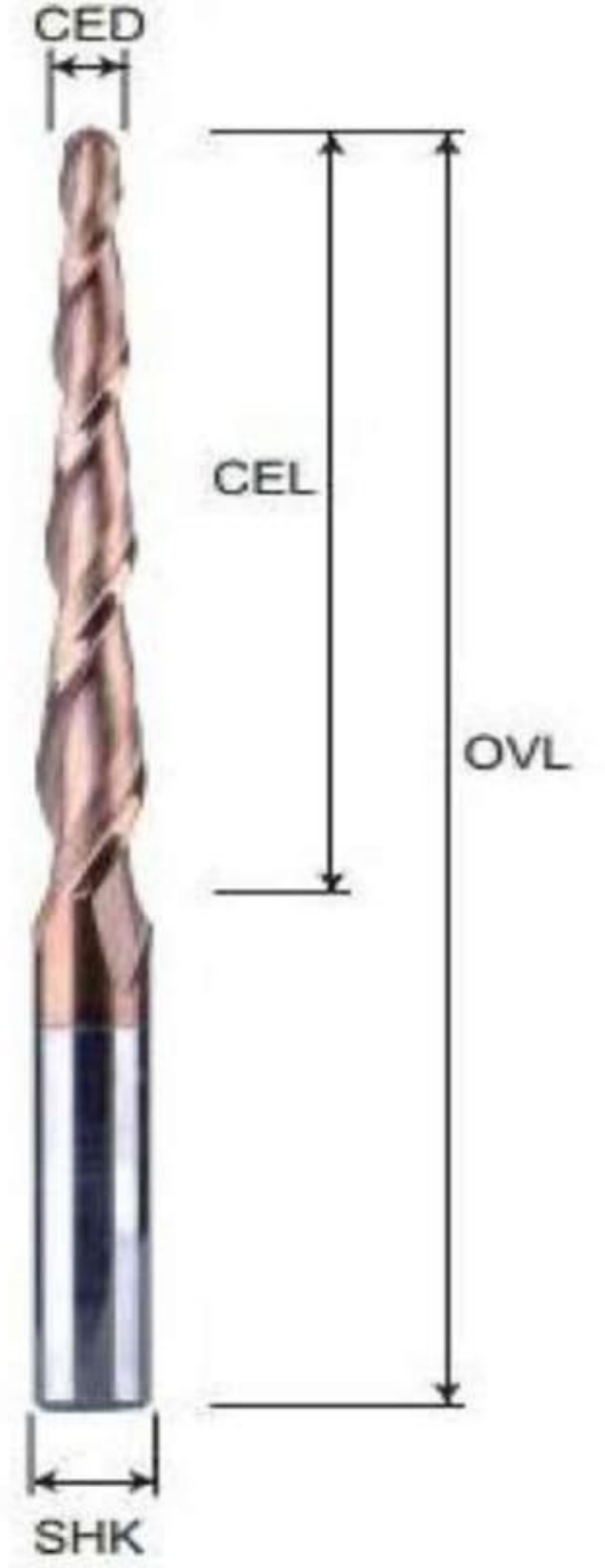

2Z İki Ağızlı Ahşap İşleme Kompozit Bıçağı

NO NO	Sap Çapı SHK	Bıçak Çapı CED	İlk Kesici Kenar 长	Bıçak Uzunluk CEL	Toplam Uzunluk OVL
10363112	3.175	3.175	2.5	12	50
10363115	3.175	3.175	2.5	15	50
10363117	3.175	3.175	2.5	17	50
10363122	3.175	3.175	2.5	22	55
10360417	4	4	3.5	17	45
10360422	4	4	3.5	22	50
10360425	4	4	3.5	25	55
10360432	4	4	3.5	32	70
10360517	5	5	4	17	50
10360522	5	5	4	22	50
10360617	6	6		17	50
10360622	6	6		22	50
10360625	6	6		25	55
10360632	6	6		32	70
10360825	8	8	7	25	60
10360832	8	8	7	32	70
10360845	8	8	7	45	80
10361035	10	10	7	35	75
10361045	10	10	7	45	90
10361052	10	10	7	52	100
10361232	12	12	7	35	80
10361252	12	12	7	52	100
10361273	12.7	12.7	9	35	80
10361275	12.7	12.7	9	52	100
10361452	14	14		52	100
10361652	16	16		52	110
10361662	16	16		62	120
10361672	16	16		72	130
10362052	20	20		52	120
10362072	20	20		72	130

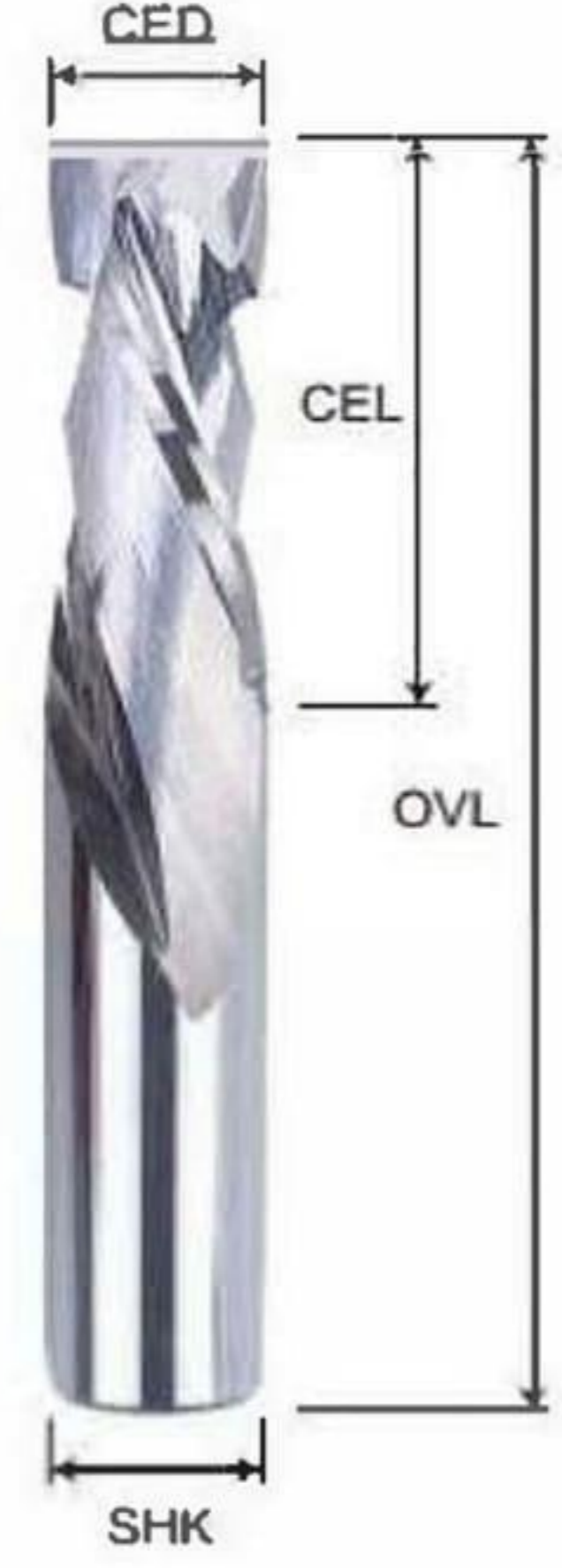

3Z Üç Ağızlı Ahşap İşleme Kompozit Bıçağı

NO NO	Sap Çapı SHK	Bıçak Çapı CED	Bıçak Uzunluk CEL	Toplam Uzunluk OVL
10380622	6	6	22	50
10380625	6	6	25	55
10380632	6	6	32	70
10380825	8	8	25	60
10380832	8	8	32	70
10380845	8	8	45	80
10381035	10	10	35	75
10381045	10	10	45	90
10381052	10	10	52	100
10381235	12	12	35	80
10381252	12	12	52	100
10381273	12.7	12.7	35	80
10381275	12.7	12.7	52	100
10381452	14	14	52	100
10381652	16	16	52	110
10381662	16	16	62	120
10381672	16	16	72	130
10382052	20	20	52	120
10382072	20	20	72	130

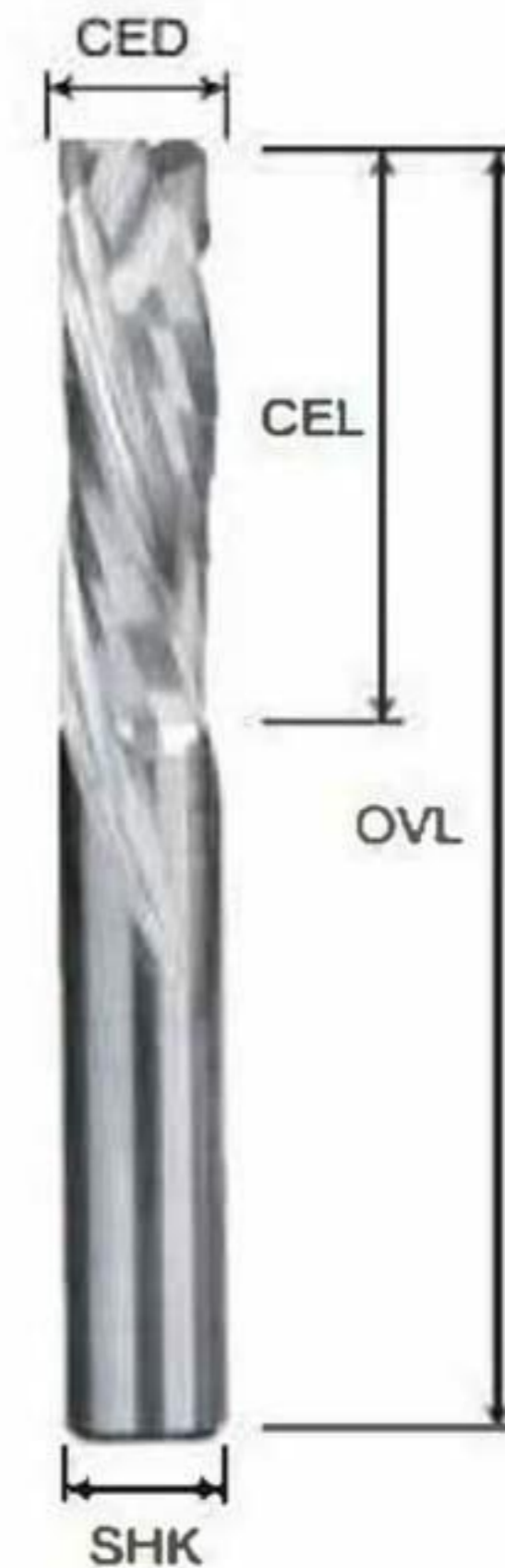

Çoklu Delik Delme Matkapları ve Minifix Bıçakları



PCD Woodworking Edge Banding Jointing
Rabbeting Cutter Diamond chip-free Joining Cutter
Diamond chip-free Joining Cutter

*Woodworking drill bit /
Special drill bit for aluminum
honeycomb panel*



DOWEL DRILLS

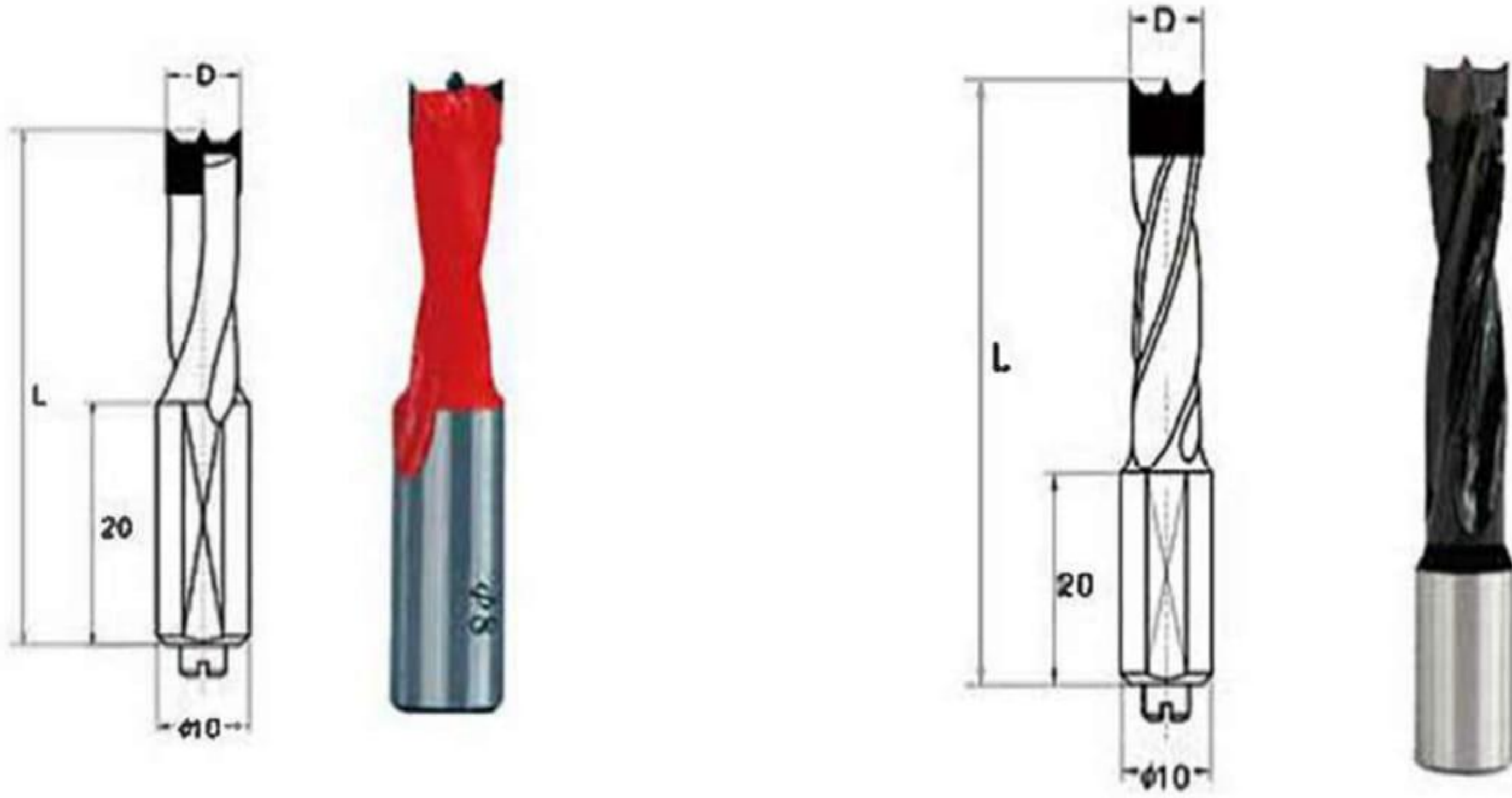

Part NO.	ØD	L	DIRECTION
ST004201	4	57/70	L+R
ST004202	5	57/70	L+R
ST004203	6	57/70	L+R
ST004204	7	57/70	L+R
ST004205	8	57/70	L+R
ST004206	9	57/70	L+R
ST004207	10	57/70	L+R
ST004208	11	57/70	L+R
ST004209	12	57/70	L+R
ST004210	13	57/70	L+R
ST004211	14	57/70	L+R
ST004212	15	57/70	L+R
ST004213	16	57/70	L+R
ST004214	17	57/70	L+R

THROUGH HOLE DRILLS

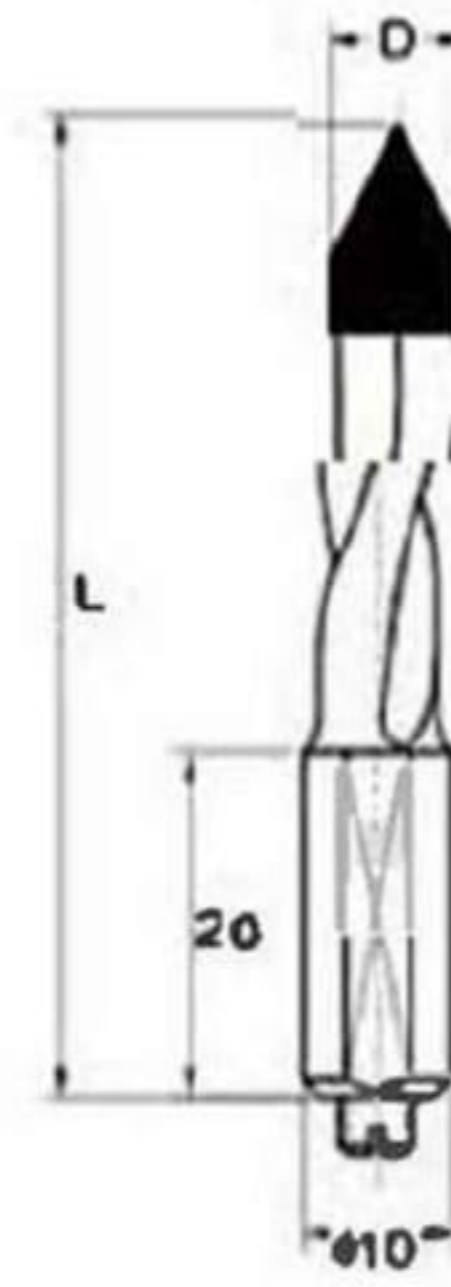

Part NO.	ØD	L	DIRECTION
ST004101	3	57/70	L+R
ST004102	4	57/70	L+R
ST004103	5	57/70	L+R
ST004104	6	57/70	L+R
ST004105	7	57/70	L+R
ST004106	8	57/70	L+R
ST004107	9	57/70	L+R
ST004108	10	57/70	L+R
ST004109	11	57/70	L+R
ST004110	12	57/70	L+R
ST004111	13	57/70	L+R
ST004112	14	57/70	L+R
ST004113	15	57/70	L+R
ST004114	16	57/70	L+R

BORING DRILLS

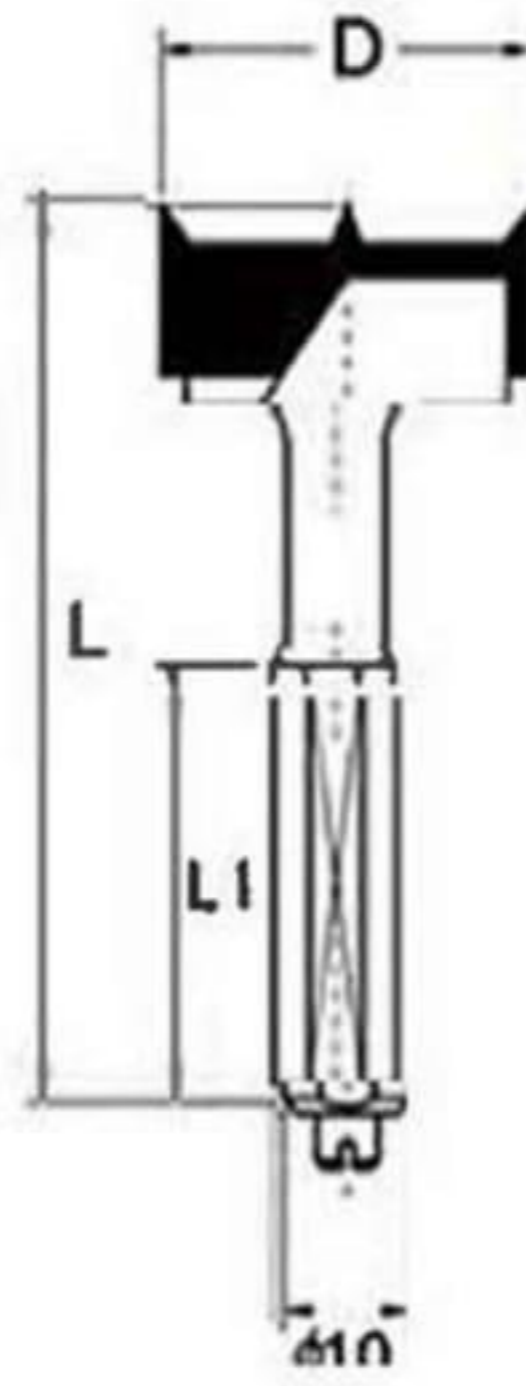

Part NO.	ØD	L1	L	DIRECTION
ST004501	15	30	70	L+R
ST004502	18	30	70	L+R
ST004503	20	30	70	L+R
ST004504	22	30	70	L+R
ST004505	25	30	70	L+R
ST004506	28	30	70	L+R
ST004507	30	30	70	L+R
ST004508	32	30	70	L+R
ST004509	35	30	70	L+R
ST004510	45	30	70	L+R
ST004511	50	30	70	L+R
ST004512	55	30	70	L+R
ST004513	60	30	70	L+R



Takam Uçlu Kesici Takımlar

PCD Woodworking Edge Banding Jointing
Rabbeting Cutter Diamond chip-free Jointing Cutter
Diamond chip-free Jointing Cutter

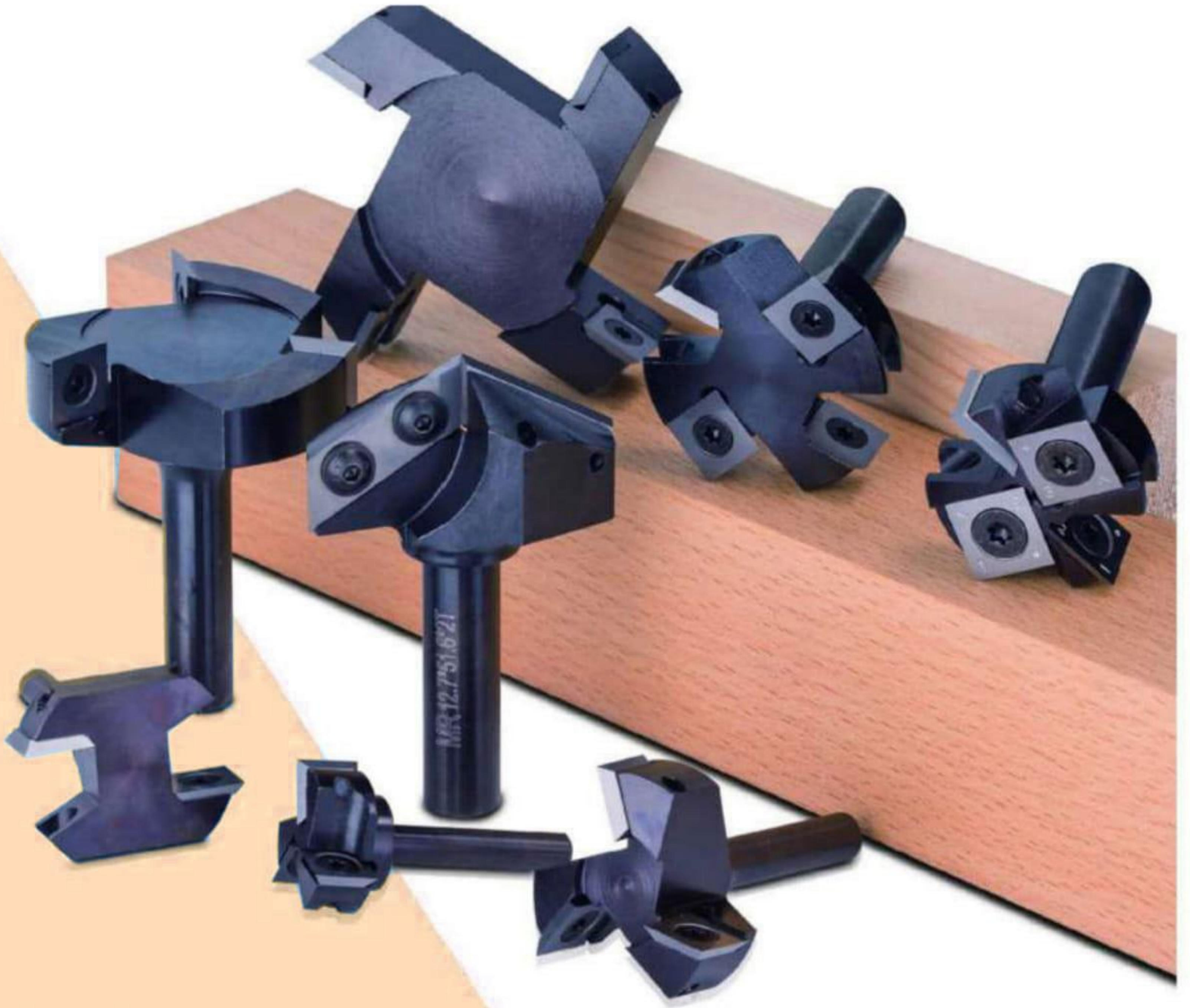

**Diamond
Tools**

Üç Ağızlı Alt Freze Bıçağı



Sap çapı: 6/6.35/8/10/12/12.7/20 mm seçenekli, diş sayısı: 3Z, 4Z

NO	Parça No	Boyut mm	Sap Çapı	Bıçak Çapı	Bıçak Uzunluğu	Bıçak Boyutu	Diş Sayısı
NO.	Part No.	SIZE mm	Ød SHK	ØD CED	H	Blade size	Z
1	ST003201	d8*D35*H12*3Z	8	35	12	12*12*1.5*35°	3
2	ST003202	d8*D37*H12*3Z	8	37	12	12*12*1.5*35°	3
3	ST003203	d6.35*D38.1*H12*3Z	6.35	38.1	12	12*12*1.5*35°	3
4	ST003204	d8*D39*H12*3Z	8	39	12	12*12*1.5*35°	3
5	ST003205	d12*D50.8*H12*3Z	12	50.8	12	12*12*1.5*35°	3
6	ST003206	d12*D53*H12*3Z	12	53	12	12*12*1.5*35°	3
7	ST003207	d12*D59*H12*3Z	12	59	12	12*12*1.5*35°	3
8	ST003208	d12*D61*H12*3Z	12	61	12	12*12*1.5*35°	3
9	ST003209	d12*D63.5*H12*3Z	12	63.5	12	12*12*1.5*35°	3
10	ST003210	d8*D40*H12*4Z	8	40	12	12*12*1.5*35°	4
11	ST003211	d12*D50.8*H12*4Z	12	50.8	12	12*12*1.5*35°	4
12	ST003212	d12*D63.5*H12*4Z	12	63.5	12	12*12*1.5*35°	4
13	ST003213	d12*D76.2*H12*4Z	12	76.2	12	12*12*1.5*35°	4

Eğimli Dişli Levha Kesme Bıçağı



NO	Parça No	Boyut mm	Sap Çapı	Bıçak Çapı	Bıçak Uzunluğu	Bıçak Boyutu	Diş Sayısı
NO.	Part No.	SIZE mm	Ød SHK	ØD CED	H	Blade size	Z
1	ST003214	d12*D63.5*H12*3Z	12	63.5	12	12*12*1.5*35°C2	3
1	ST003215	d12.7*D63.5*H12*3Z	12.7	63.5	12	12*12*1.5*35°C2	3

Dört Ağızlı T Tipi Freze Bıçağı



Sap çapı: 6/6.35/8/10/12/12.7/20 mm seçenekli, diş sayısı: 2+2

NO	Parça No	Boyut mm	Sap Çapı	Bıçak Çapı	Bıçak Uzunluğu	Bıçak Boyutu	Diş Sayısı
NO.	Part No.	SIZE mm	Ød SHK	ØD CED	H	Blade size	Z
1	ST003301	d6.35*D31.75*H12*2+2Z	6.35	31.75	12	12*12*1.5*35°14* 14*2.0*30	2+2
2	ST003302	d6*D38.1*H12*2+2Z	6	38.1	12	12*12*1.5*35°14* 14*2.0*30	2+2
3	ST003303	d8*D38.1*H12*2+2Z	8	38.1	12	12*12*1.5*35°14* 14*2.0*30	2+2
4	ST003304	d12*D38.1*H12*2+2Z	12	38.1	12	12*12*1.5*35°14* 14*2.0*30	2+2
5	ST003305	d12*D45*H12*2+2Z	12	45	12	12*12*1.5*35°14* 14*2.0*30	2+2
6	ST003306	d12*D50.8*H12*2+2Z	12	50.8	12	12*12*1.5*35°14* 14*2.0*30	2+2
7	ST003307	d12*D63.5*H12*2+2Z	12	63.5	12	14*14*2.0*30	2+2

İki Ağızlı Alt Freze Bıçağı



Sap çapı: 6/6.35/8/10/12/12.7/20 mm seçenekli, diş sayısı: 2

NO	Parça No	Boyut mm	Sap Çapı	Bıçak Çapı	Bıçak Uzunluğu	Bıçak Boyutu	Diş Sayısı
NO.	Part No.	SIZE mm	Ød SHK	ØD CED	H	Blade size	Z
1	ST003401	d12*D25.4*H12*2Z	12	25.4	12	12*12*1.5*35°	2
2	ST003402	d12*D28*H14*2Z	12	28	14	14*14*2.0*30°	2
3	ST003403	d12*D30*H12*2Z	12	30	12	15*15*2.5*30°	2
4	ST003404	d12*D38.1*H12*2Z	12	38.1	12	12*12*1.5*35°	2
5	ST003405	d12*D40*H12*2Z	12	40	12	20*12*1.5*35°	2

CNC Freze Ucu (Temiz Alt Kesimli)



Sap caı: 16/20 seçenekli

NO	Parça No	Boyut mm	Sap Çapı	Bıçak Çapı	Bıçak Uzunluğu	Bıçak Boyutu	Diş Sayısı
NO.	Part No.	SIZE mm	Ød SHK	ØD CED	H	Blade size	Z
1	ST003601	d16*D32*H50	16	32	50	12*12*2.2	2+2
2	ST003602	d16*D19*H65	16	19	65	12*12*2.2	2+2
3	ST003603	d16*D30*H80	16	30	80	12*12*2.2	2+2
4	ST003604	d16*D30*H100	16	30	100	12*12*2.2	2+2
5	ST003605	d16*D30*H120	16	30	120	12*12*2.2	2+2

V Tipi Bıçak

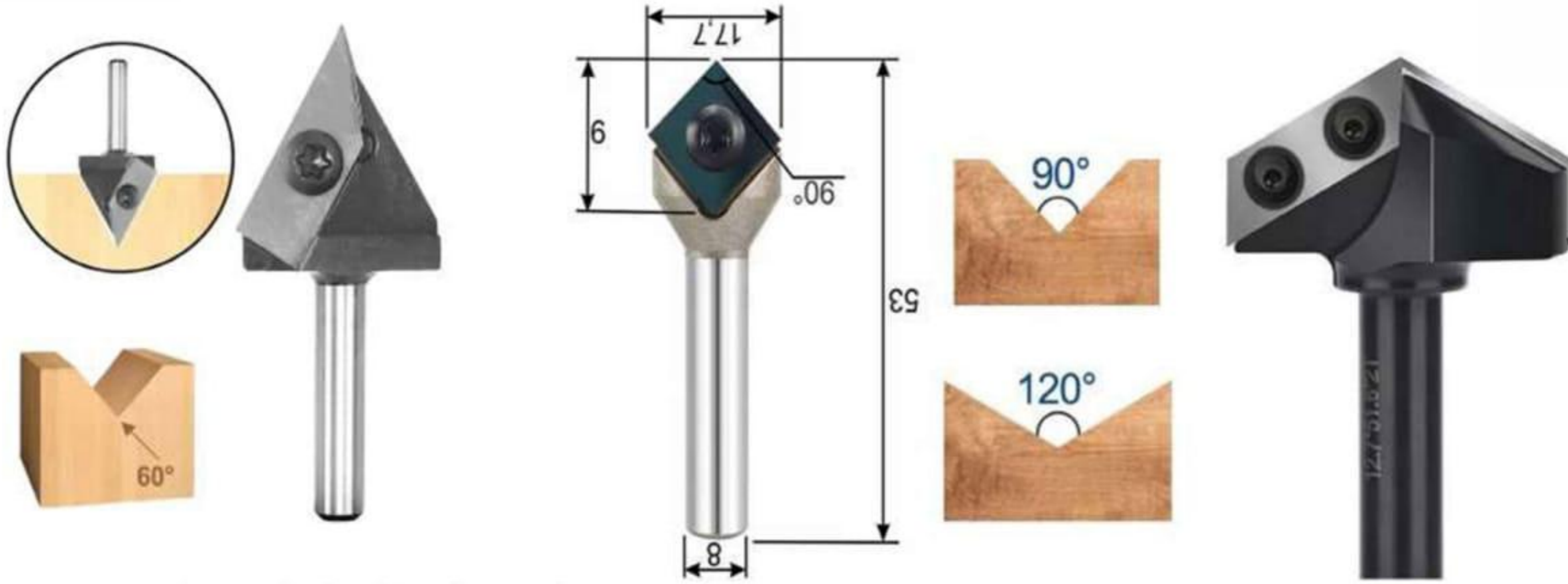

Sap çapı: 6/6.35/8/10/12/12.7/20 mm seçenekli

NO	Parça No	Boyut mm	Sap Çapı	Bıçak Çapı	Eğim Açısı	Bıçak Boyutu	Diş Sayısı
NO.	Part No.	SIZE mm	Ød SHK	ØD CED	a°	Blade size	Z
1	ST003501	d6*D18.6*V45°*1Z	6	18.6	45°	27*9*1.5mm	1
2	ST003502	d6.35*D18.6*V45°*1Z	6.35	18.6	45°	27*9*1.5mm	1
3	ST003503	d12*D18.6*V45°*1Z	12	18.6	45°	27*9*1.5mm	1
4	ST003504	d6*D21*V60°*1Z	6	21	60	27*9*1.5mm	1
5	ST003505	d6.35*D21*V60°*1Z	6.35	21	60	27*9*1.5mm	1
6	ST003506	d12*D21*V60°*1Z	12	21	60	27*9*1.5mm	1
7	ST003507	d6*D16.9*V90°*1Z	6	16.9	90	12*12*1.5*35°	1
8	ST003508	d6.35*D16.9*V90°*1Z	6.35	16.9	90	12*12*1.5*35°	1
9	ST003509	d8*D16.9*V90°*1Z	8	16.9	90	12*12*1.5*35°	1
10	ST003510	d12*D16.9*V90°*1Z	12	16.9	90	12*12*1.5*35°	1
11	ST003511	d12*D38*V90°*1+1Z	12	38	90	12*20*1.5 12*30*1.5	1+1
12	ST003512	d12*D56*V90°*1+1Z	12	56	90	12*30*1.5 12*40*1.5	1+1
12	ST003512	d12*D56*V120°*2Z	12	56	120	12*40*1.5异形-13	2
13	ST003513	d12*D66*V120°*2Z	12	66	120	12*50*1.5异形-13	2
14	ST003514	d12*D38*V90°*2Z	12	38	90	定制刀片-15	2
15	ST003515	d12*D51.6*V120°*2Z	12	51.6	120	定制刀片-16	2

Kenar Düzeltme Bıçağı (Üst ve Alt Rulmanlı)



Sap çapı: 8/12/12.7 mm seçeneği

NO	Parça No	Boyut mm	Sap Çapı	Bıçak Çapı	Bıçak Uzunluğu	Bıçak Boyutu	Diş Sayısı
NO.	Part No.	SIZE mm	Ød SHK	ØD CED	H	Blade size	Z
1	ST003701	d12.7*D19*H50	12.7	19	50	10.5*10.5*2.2	2+2
2	ST003702	d12.7*D19*H65	12.7	19	65	10.5*10.5*2.2	2+2
3	ST003703	d16*D30*H50	16	30	50	12*12*2.2	2+2
4	ST003704	d16*D30*H65	16	30	65	12*12*2.2	2+2
5	ST003705	d16*D30*H80	16	30	80	12*12*2.2	2+2
6	ST003706	d12*D30*H20	12	30	20	12*12*2.2	2+2
7	ST003707	d12*D19*H30	12	19	30	12*30	2
8	ST003708	d12*D19*H40	12	19	40	12*40	2
9	ST003709	d12*D19*H50	12	19	50	12*50	2
10	ST003710	d12*D19*H60	12	19	60	12*60	2
11	ST003711	d12*D19*H50	12	19	50	12*12*2.2	1+1
12	ST003712	d12*D19*H65	12	19	65	12*12*2.2	1+1
13	ST003713	d12*D19.05*H108	12	19.05	108	50*12*1.7*35°*3H	4

Kenar Düzeltme Bıçağı



Sap çapı: 6/6.35/8/12/12.7 mm seçeneği

NO	Parça No	Boyut mm	Sap Çapı	Bıçak Çapı	Bıçak Uzunluğu	Bıçak Boyutu	Diş Sayısı
NO.	Part No.	SIZE mm	Ød SHK	ØD CED	H	Blade size	Z
1	ST003801	d6*D19*H12	6	19	12	12*12*1.5*35°	2
2	ST003802	d6.35*D19*H12	6.35	19	12	12*12*1.5*35°	2
3	ST003803	d8*D19*H12	8	19	12	12*12*1.5*35°	2
4	ST003804	d12*D19*H20	12	19	20	12*20	2
5	ST003805	d12*D19*H30	12	19	30	12*30	2
6	ST003806	d12*D19*H40	12	19	40	12*40	2
7	ST003807	d12*D19*H50	12	19	50	12*50	2
8	ST003808	d12*D19*H60	12	19	60	12*60	2

Kenar Düzeltme Bıçağı (Alt Rulmanlı)



Sap çapı: 8/12/12.7 mm seçenekli

NO	Parça No	Boyut mm	Sap Çapı	Bıçak Çapı	Bıçak Uzunluğu	Bıçak Boyutu	Diş Sayısı
NO.	Part No.	SIZE mm	Ød SHK	ØD CED	H	Blade size	Z
1	ST003901	d12*D19.05*H50	12	19.05	50	12*50	2
2	ST003902	d12.7*D19.05*H50	12.7	19.05	50	12*50	2
3	ST003903	d12*D19*H20	12	19	20	12*20	2
4	ST003904	d12*D19*H30	12	19	30	12*30	2
5	ST003905	d12*D19*H40	12	19	40	12*40	2
6	ST003906	d12*D19*H50	12	19	50	12*50	2
7	ST003907	d12*D19*H60	12	19	60	12*60	2

Eğimli Kenar Bıçağı



NO	Parça No	Boyut mm	Sap Çapı	Bıçak Çapı	Açı	Bıçak Boyutu	Diş Sayısı
NO.	Part No.	SIZE mm	Ød	ØD CED	V	Blade size	Z
1	ST004601	d6.35*D21.6*H15	6.35	21.6	15	12*12*2.2	2
2	ST004602	d8*D27.43*H30	8	27.43	30	12*12*2.2	2
3	ST004603	d6.35*D27*H45	6.35	27	45	12*12*2.2	2
4	ST004604	d8*D27*H45	8	27	45	12*12*2.2	2
5	ST004605	d8*D32*H45	8	32	45	12*12*2.2	2

Yuvarlak Köşe Bıçağı / 45 Eğimli Kenar Bıçağı



NO	Parça No	Boyut mm	Sap Çapı	Bıçak Çapı	Yarıçap	Bıçak Boyutu	Diş Sayısı
NO.	Part No.	SIZE mm	Ød	ØD CED		Blade size	Z
1	ST004701	d6.35*D27.4*R1	6.35	27.4	1	12*12*1.5*R1	2
2	ST004702	d6.35*D27.4*R2	6.35	27.4	2	12*12*1.5*R2	2
3	ST004703	d6.35*D27.4*R3	6.35	27.4	3	12*12*1.5*R3	2
4	ST004704	d8*D27.4*R3	8	27.4	3	12*12*1.5*R3	2

Yuvarlak Köşe Bıçağı



NO	Parça No	Boyut mm	Sap Çapı	Bıçak Çapı	Yarıçap	Bıçak Boyutu	Diş Sayısı
NO.	Part No.	SIZE mm	Ød	ØD CED		Blade size	Z
1	ST004801	d8*D26.5*R2	8	26.5	2	15.9*9*1.5*R2	2
2	ST004802	d8*D26.5*R3	8	26.5	3	15.9*9*1.5*R3	2
3	ST004803	d8*D26.5*R4	8	26.5	4	15.9*9*1.5*R4	2
4	ST004804	d8*D26.5*R5	8	26.5	5	15.9*9*1.5*R5	2
5	ST004805	d8*D27*R6.35	8	27	6.35	15.9*9*1.5*R6.	2

Temiz Alt Bıçağı



NO	Parça No	Boyut mm	Sap Çapı	Bıçak Çapı	Bıçak Uzunluğu	Bıçak Boyutu	Diş Sayısı
NO.	Part No.	SIZE mm	Ød	ØD CED	H	Blade size	Z
1	ST004901	d8*D12.7*H30	8	12.7	30	10*30	2
2	ST004902	d12*D19*H20	12	19	20	12*20	2
3	ST004903	d12*D19*H30	12	19	30	12*30	2
4	ST004904	d12*D19*H40	12	19	40	12*40	2
5	ST004905	d12*D19*H50	12	19	50	12*50	2
6	ST004906	d12*D19*H60	12	19	60	12*60	2

Ahşap İşleme Bıçakları

NO	İsim	Resim	Boyut mm SIZE mm	Özellik	Uyumlu Bıçak
1	Ahşap Kare Bıçak		12*12*1.5 35°	Düz Delik	Uyumlu 2 Ağız, 3 Ağız, 4 Ağız Bıçak Rafı, 90 Derece V Tipi-12 Bıçak
2	Ahşap Kare Bıçak		12*12*2.2 35°	Düz Delik	Uyumlu Bıçak Rafı Aynı Zamanda 2 Ağız, 3 Ağız, 4 Ağız Bıçak Rafı (Düz Başlı Vida Değiştirilmesi Gerekli)
3	Ahşap Kare Bıçak		14*14*2.0 30°	Dik Açı	Uyumlu T Tipi 38.1 Geniş Ön Yüz Bıçak, T Tipi 63.5 Geniş Yan Yüz Bıçak
4	Ahşap Kare Bıçak		15*15*2.5 30°	Dik Açı	Uyumlu 90 Derece 21 Geniş V Tipi Bıçak Rafı-15 Bıçak
6	Ahşap Kare Bıçak		12x12x1.5*35° -C2	Düz Delik C2 Eğimli Açı	Uyumlu Eğimli Dişli Bıçak Rafı
7	Farklı Şekil Bıçak		12*12*1.5 35° -R3	R3	Uyumlu Eğimli Kenar Bıçak Rafı
8	R6.35 Bıçak		15.9*9*1.5 -R6.35	R6.35	Uyumlu Yuvarlak Köşe Bıçak Rafı
9	Açık Tip V Şekilli Bıçak		Açık Tip 45/60 Derece Genel Bıçak 2791.5	V Tip	Uyumlu 45, 60 Derece V Tipi
10	Karesi Bıçak		12*40*1.5*4Ağız	Dört Ağız	Uyumlu 120 Derece 56 Genişlikte V Tipi Bıçak Rafı
11	Dikdörtgen Bıçak		12*20x1.5*35Derece 4Ağız	Dört Ağız	Uyumlu Alt Rulmanlı 20L Uzunlukta Bıçak Rafı
12	Dikdörtgen Bıçak		12*20x1.5*35Derece Tek Delik* 2Ağız	İki Ağız	Uyumlu Üst Rulmanlı, Üst ve Alt Rulmanlı 20L Uzunlukta Bıçak Rafı
13	Dikdörtgen Bıçak		30*12*1.5-4Ağız	Dört Ağız	Uyumlu 90 Derece 38 Genişlikte V Tipi Bıçak Rafı - Ekstra 2 Ağızlı; 20*12 Bıçak
14	Dikdörtgen Bıçak		30*12*1.5*35Derece 2Ağız	İki Ağız	"Uyumlu Üst Rulmanlı, Üst ve Alt Rulmanlı 30L Uzunlukta Bıçak Rafı
15	Dikdörtgen Bıçak		29.5*12*1.5-4Ağız	Dört Ağız	Uyumlu Alt Rulmanlı 30L Uzunlukta Bıçak Rafı
16	Dikdörtgen Bıçak		29.8*10*1.5 35Derece *2Delik*4Ağız 2孔*四刃		Uyumlu Kenar Düzeltme Bıçağı 08*30L Uzunlukta Bıçak Rafı
17	Dikdörtgen Bıçak		50*12*1.5-2Delik*4Ağız	2Delik *Dört Ağız	Uyumlu Alt Rulmanlı 50L Uzunlukta Bıçak Rafı
18	Dikdörtgen Bıçak		50*12*1.7-3Delik*4Ağız	3Delik *Dört Ağız	Uyumlu Üst ve Alt Rulmanlı 50L Uzunlukta Bıçak Rafı

Sert metal kazıma bıçağı Carbide engraving knife



CNC işleme merkezi, yüksek hızlı *freze* makinesi, birleşik oyma makinesi, taşınabilir oyma makinesi için uygundur.

Top wire cutter

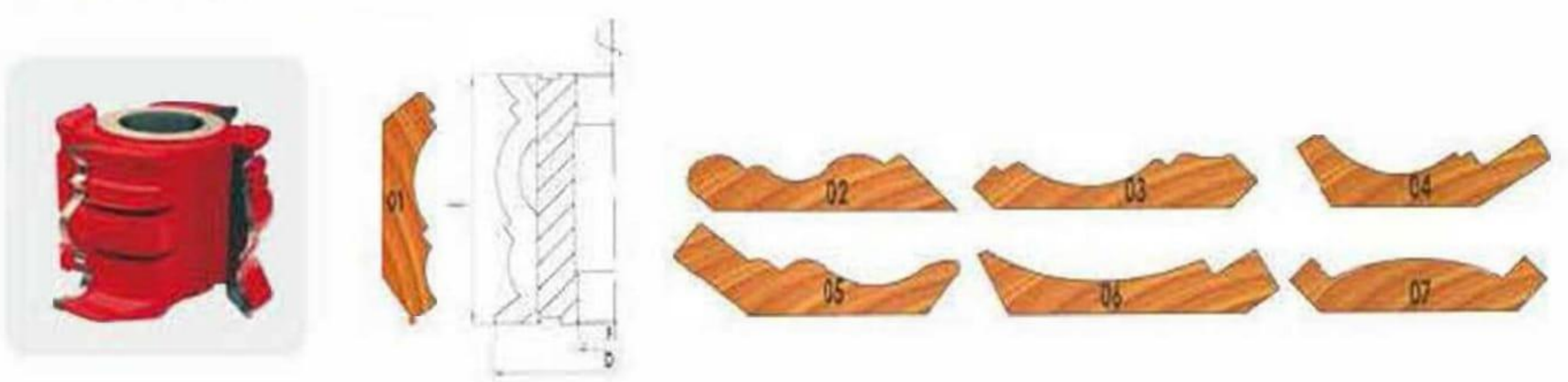

Parmak ekleme bıçağı Finger joint knife

Entegre malzeme ve mobilya işleme için uygundur, ayrıca ham madde verimliliğini arttırmada etkilidir.



Parmak ekleme bıçağı Discarded spiral knife



Düz bıçak, oluk bıçağı Flat cutter, groove cutter



TCT Series



Masif ahşap, MDF, yonga levha, kontrplak, ahşap alüminyum kompozit malzemeler ve akrilik işlemek için kullanılır.

Yüksek hızlı oyma makineleri ve CNC işleme merkezlerinde kesme ve oluk açma işlemleri için uygundur.

TCT Series



Ürün özellikleri: Spiral oluk tasarımı, talaş kaldırma çok akıcıdır.

Ürün avantajları:

- 1-) Kesme kenarı keskindir, iş parçasının yüzey pürüzsüzlüğü çok idealdir.
- 2-) Kesim yüzeyi pürüzsüzdür, birleşim yerleri sıkıdır.
- 3-) Yukarıya doğru dönen bıçak, alttaki kaplama levhasının kenarlarını kırmaz; aşağıya doğru dönen bıçak ise üst kaplama levhasının kenarlarını kırmaz. Kompozit spiral, çift yüzlü kenar kırılmasını önleyebilir.
- 4-) Sert malzemeler, kaplama levhalar, çift yüzlü kompozit levhalar gibi malzemeler için uygundur.

TCT Series



Ürün özellikleri: İki bıçaklı spiral oluk tasarımı, talaş kaldırma daha hızlıdır.

Ürün avantajları:

- 1-) Derin delikler, kör delikler açmada kullanılır.
- 2-) Oluk açma açısı, özel şekilli iş parçalarının kesimi için uygundur.
- 3-) Kesim noktası kısıtlanmaz, talaş kaldırma hızlıdır.
- 4-) Yukarıya doğru dönen bıçak, alttaki kaplama levhasının kenarlarını kırmaz; aşağıya doğru dönen bıçak ise üst kaplama levhasının kenarlarını kırmaz. Kompozit spiral, çift yüzlü kenar kırılmasını önleyebilir.
- 5-) Yüksek hızlı oyma makineleri, elektrikli gravür makineleri ve CNC işleme merkezleri için uygundur.
- 6-) Kaplama levhalar, çift yüzlü kompozit levhalar, MDF, masif ahşap gibi malzemeler için uygundur.
- 7-) Yüksek hızlı çelik kesici, Sert alaşımlı kesici

High speed steel cutter



Hard alloy cutter

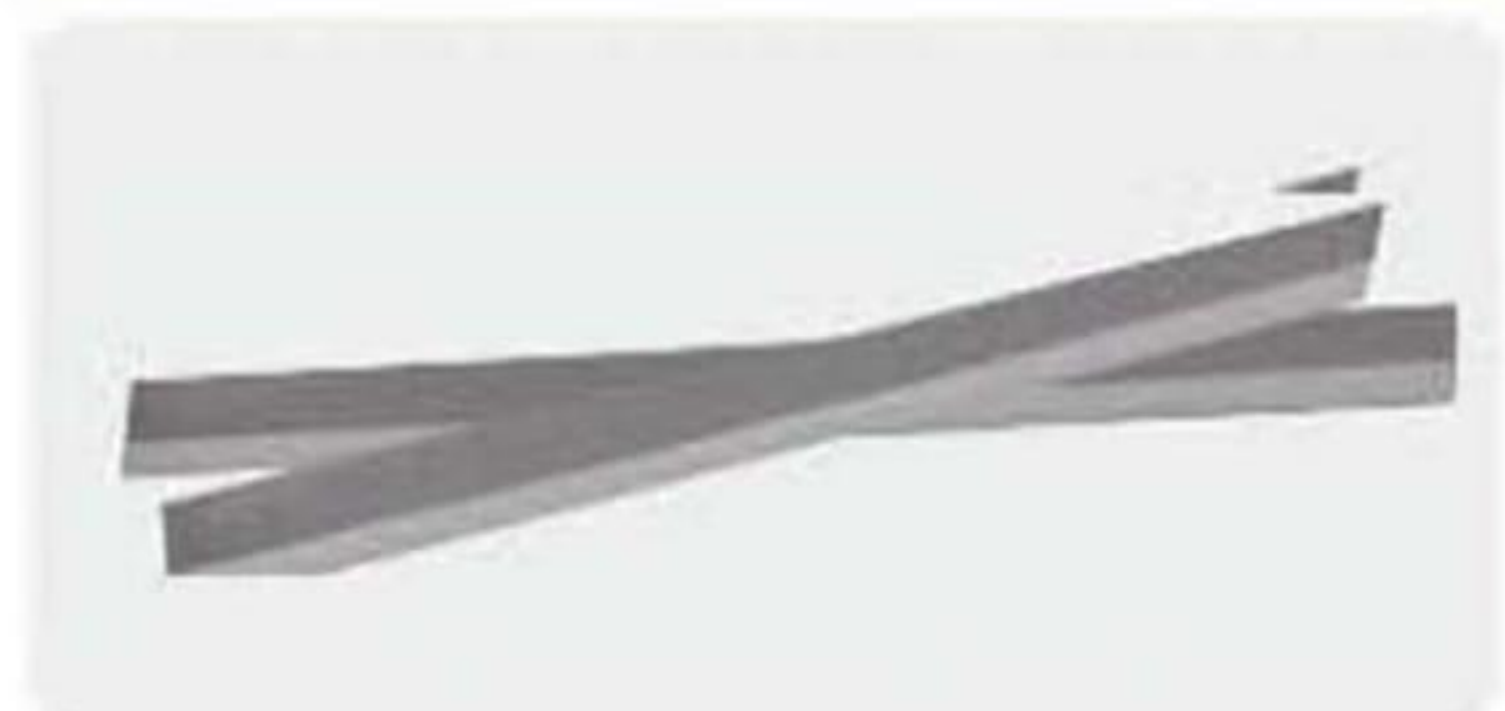

Kapı Bıçağı - A door knife

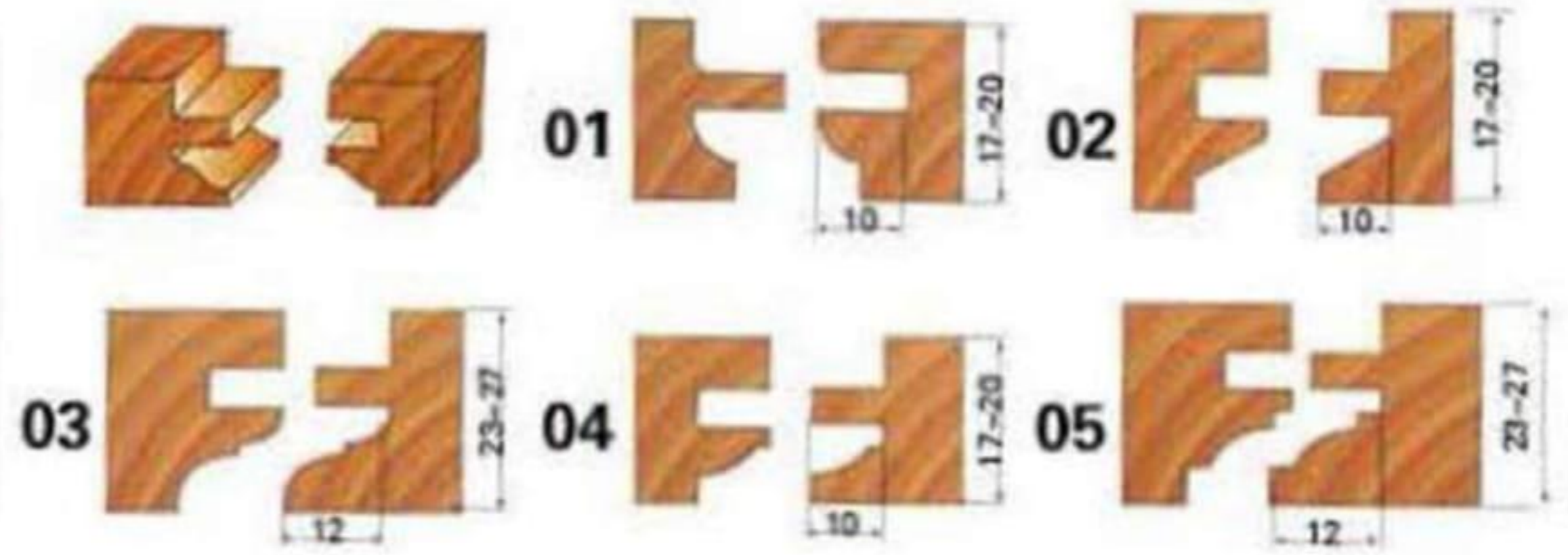

Masif kapı bıçağı Solid wood door

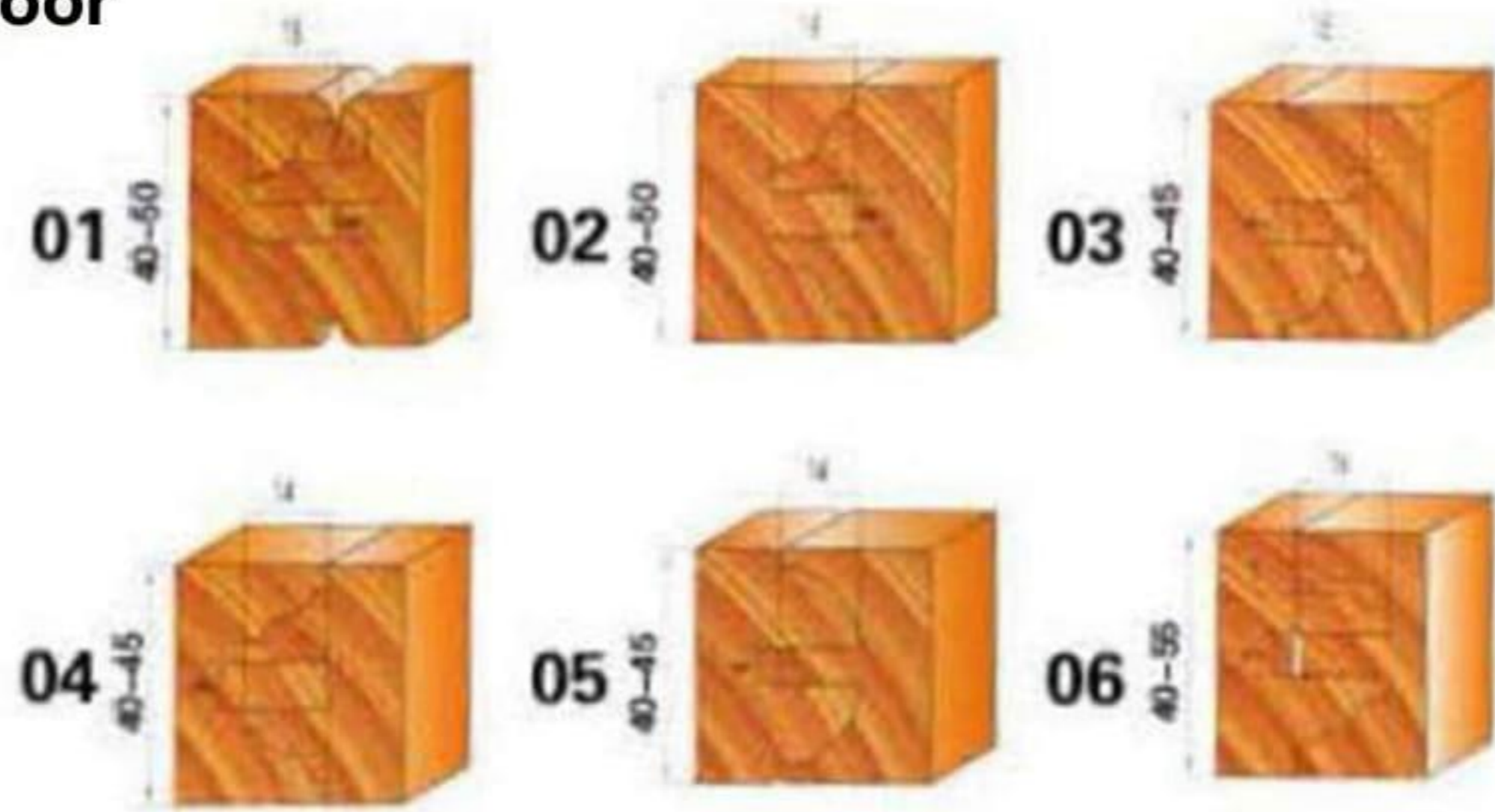

Kapı çekirdek tahtası Door core board knife

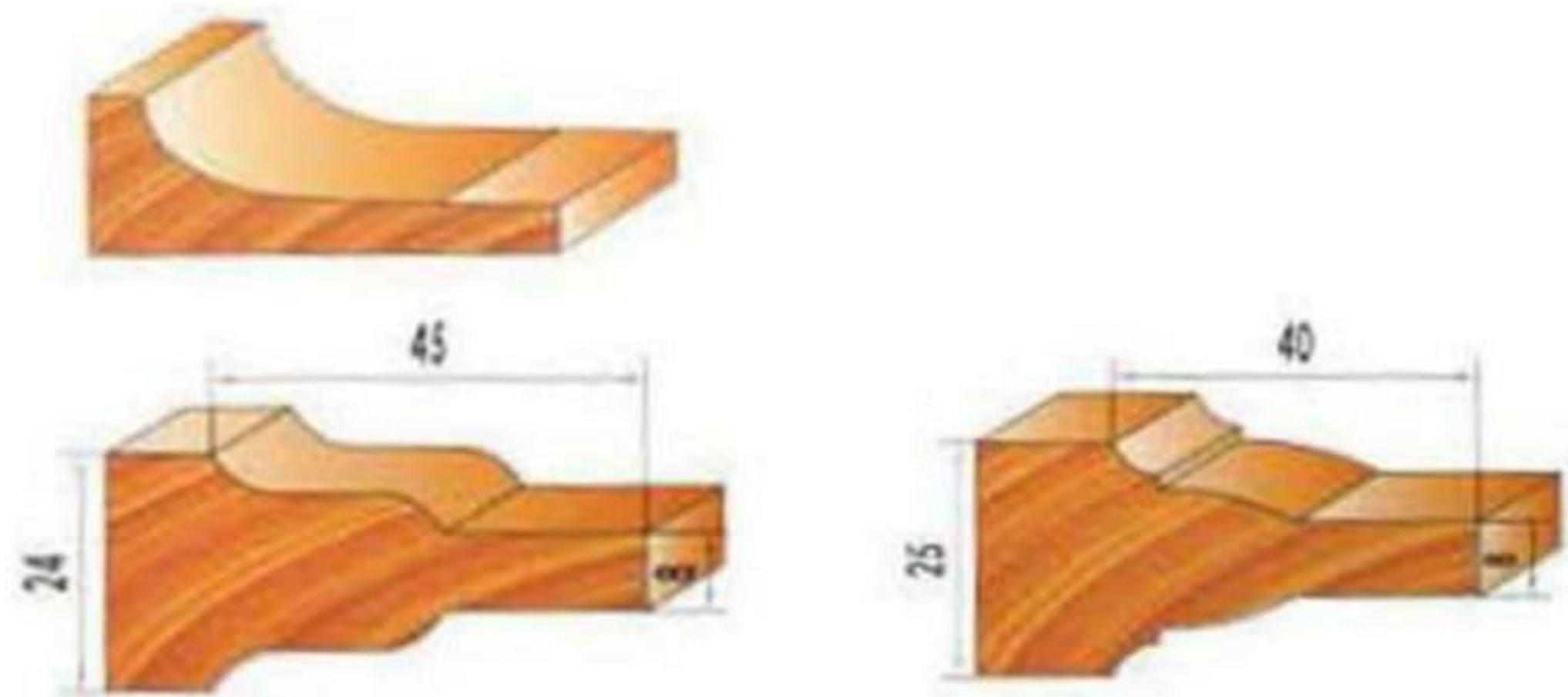

THE WHOLE STRUCTURE PCBN(PCD)

PCD (PCBN) Tam Yapılı Takımlar

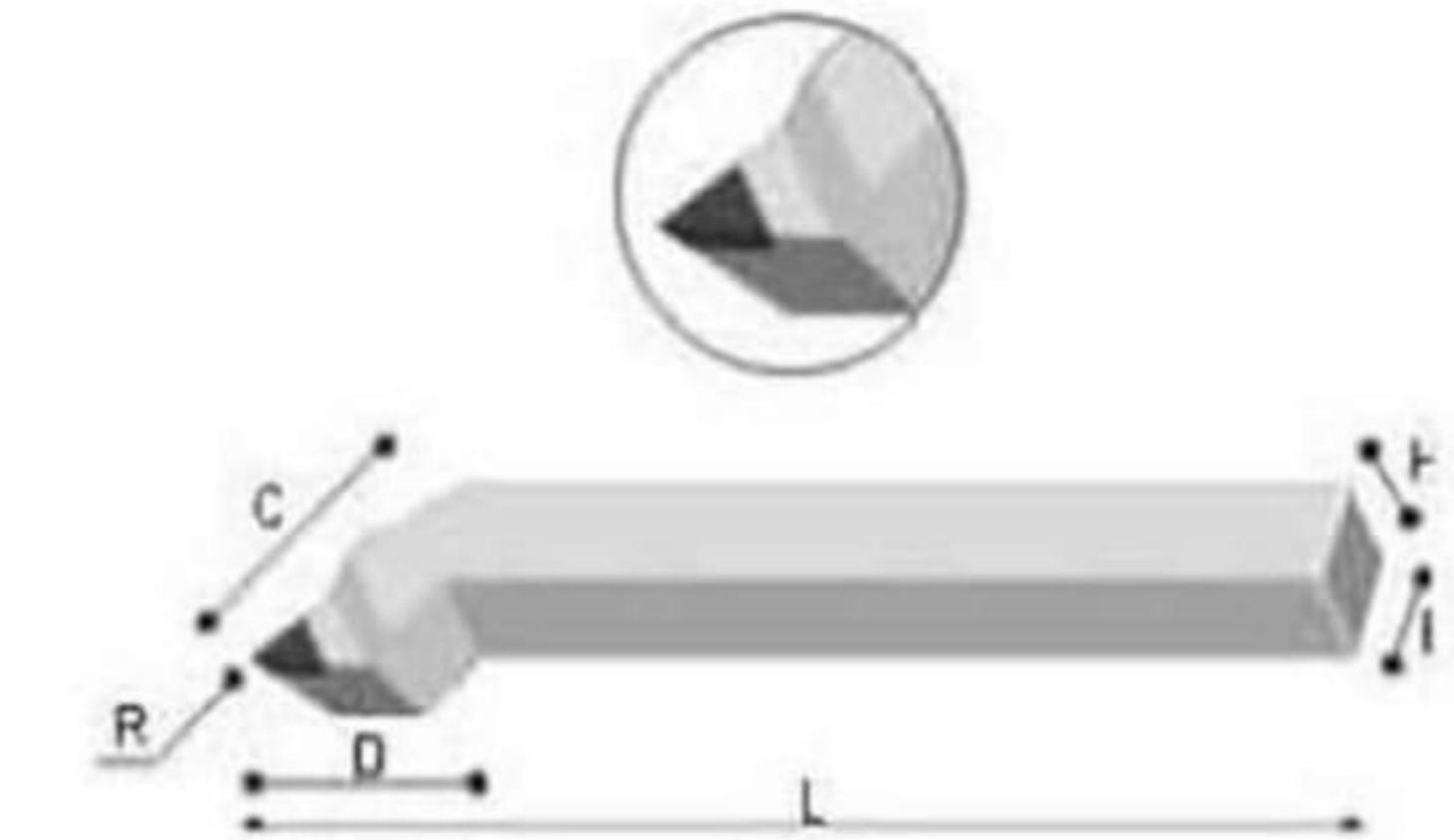
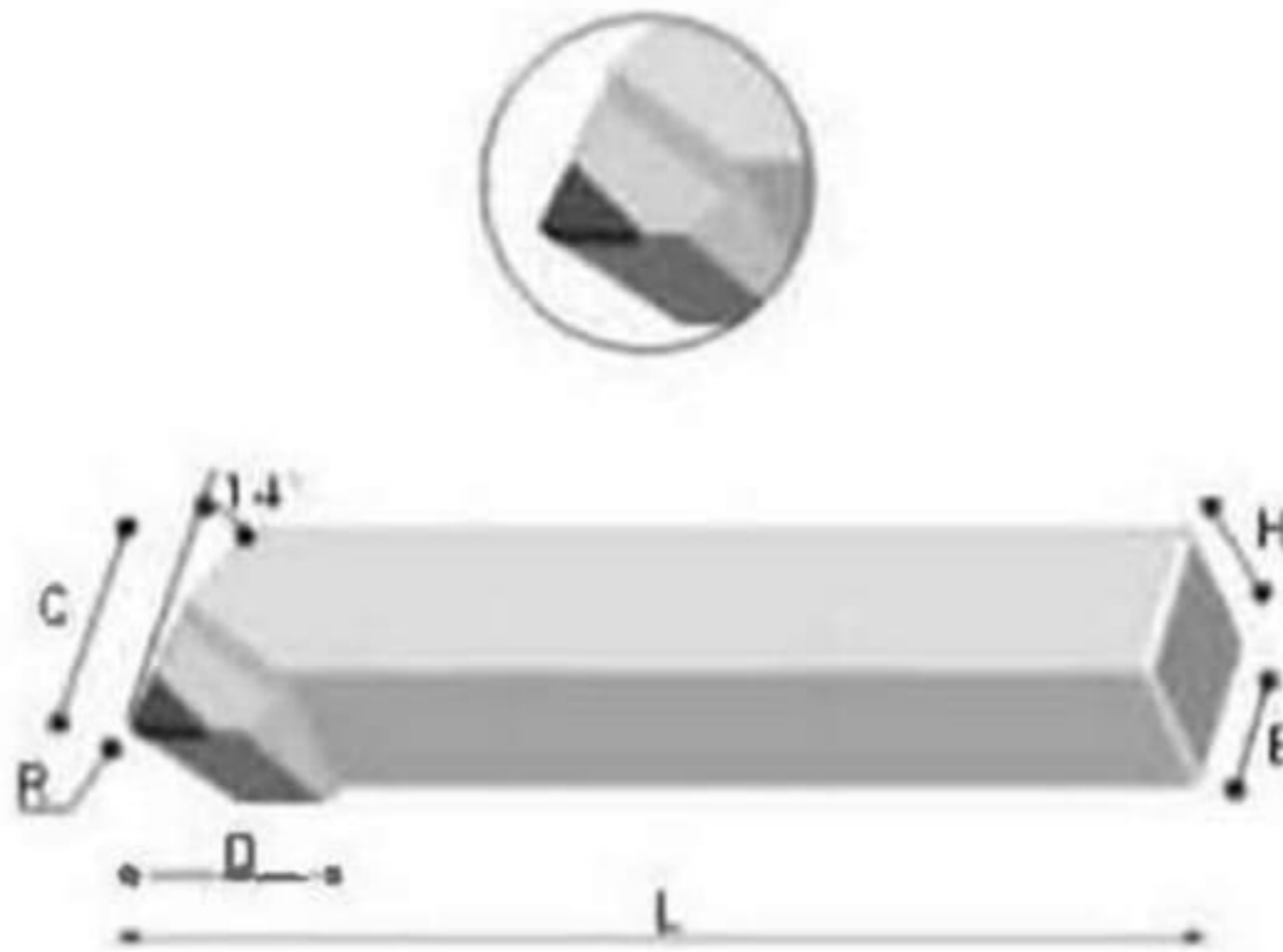
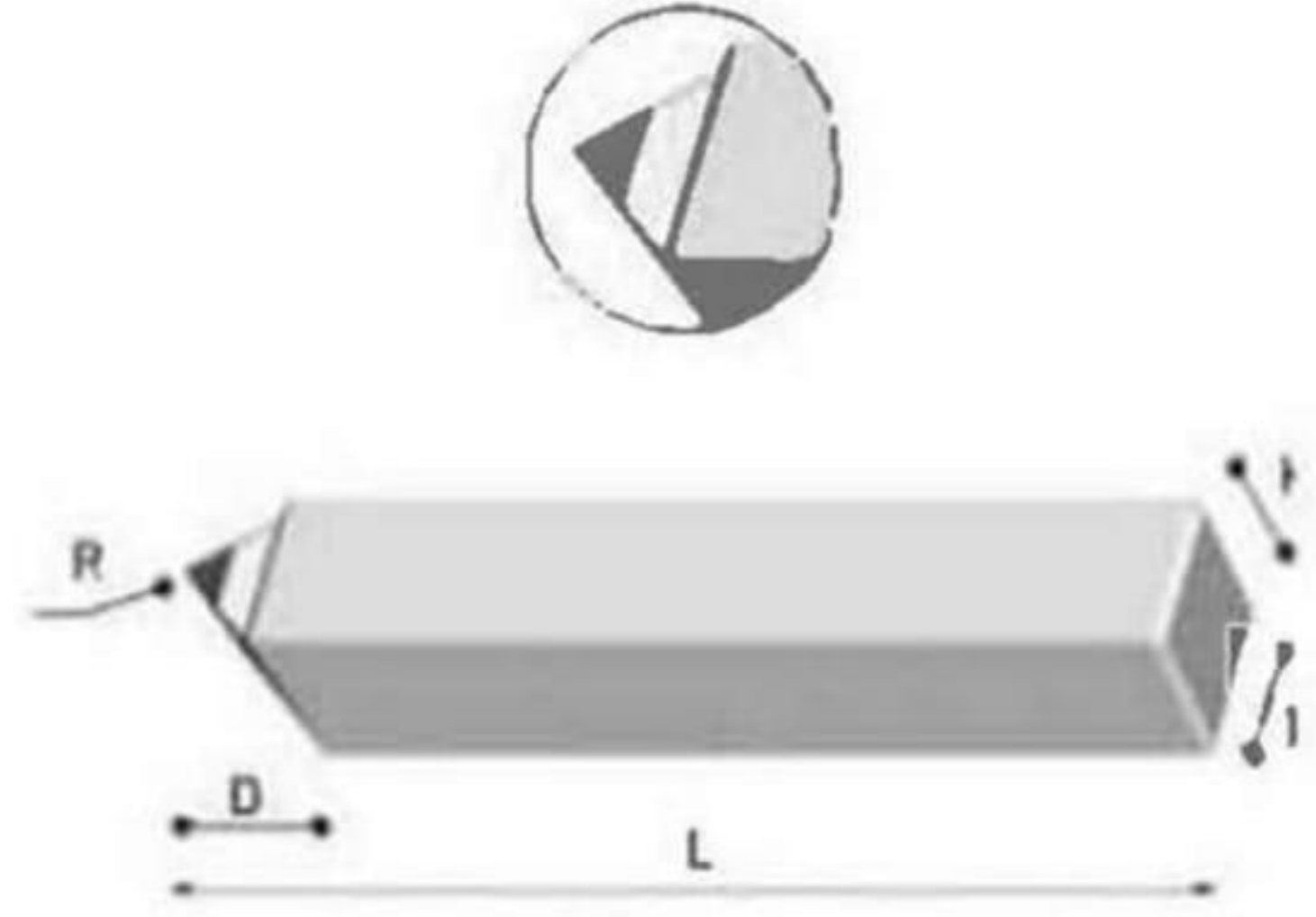
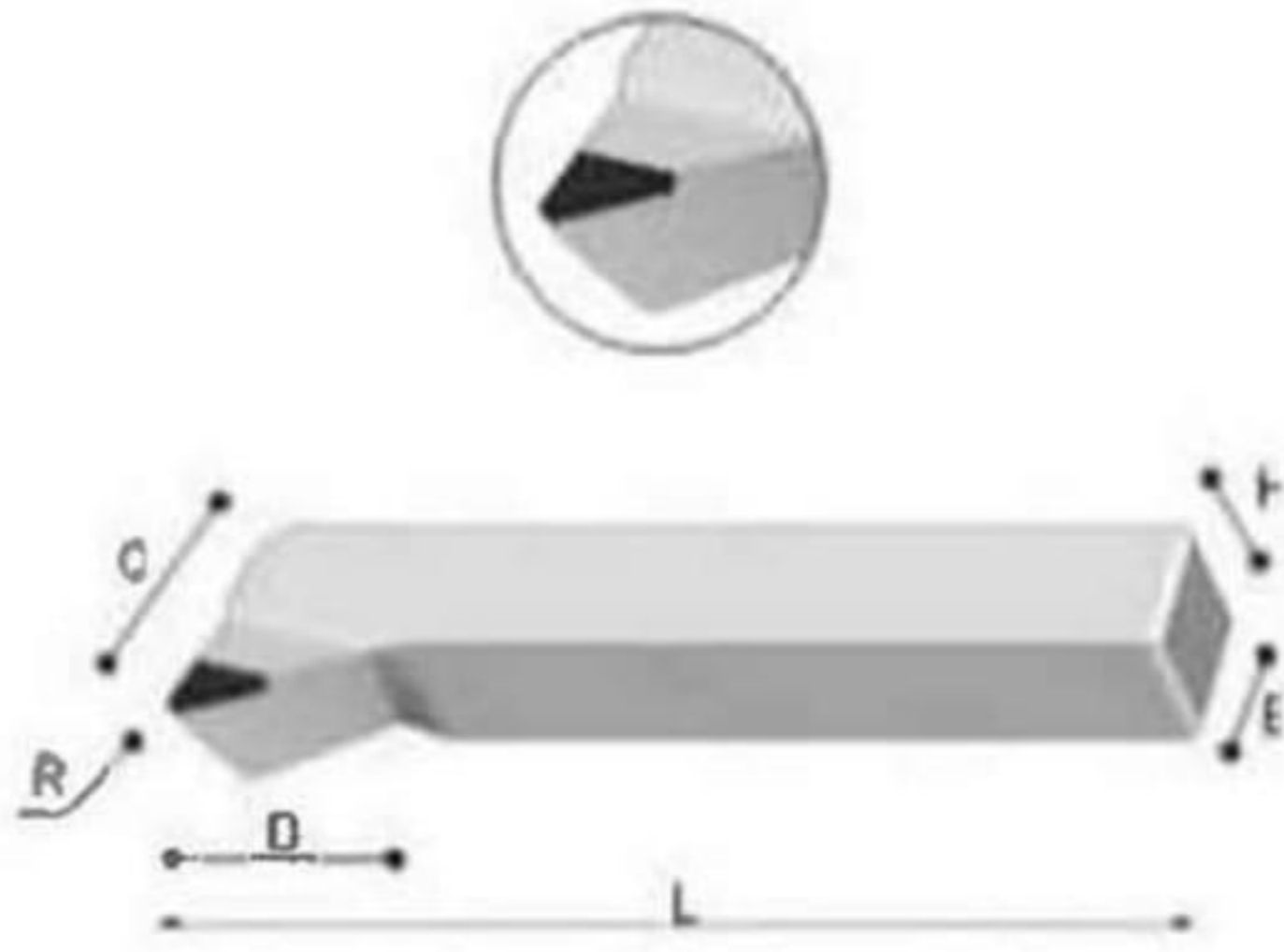
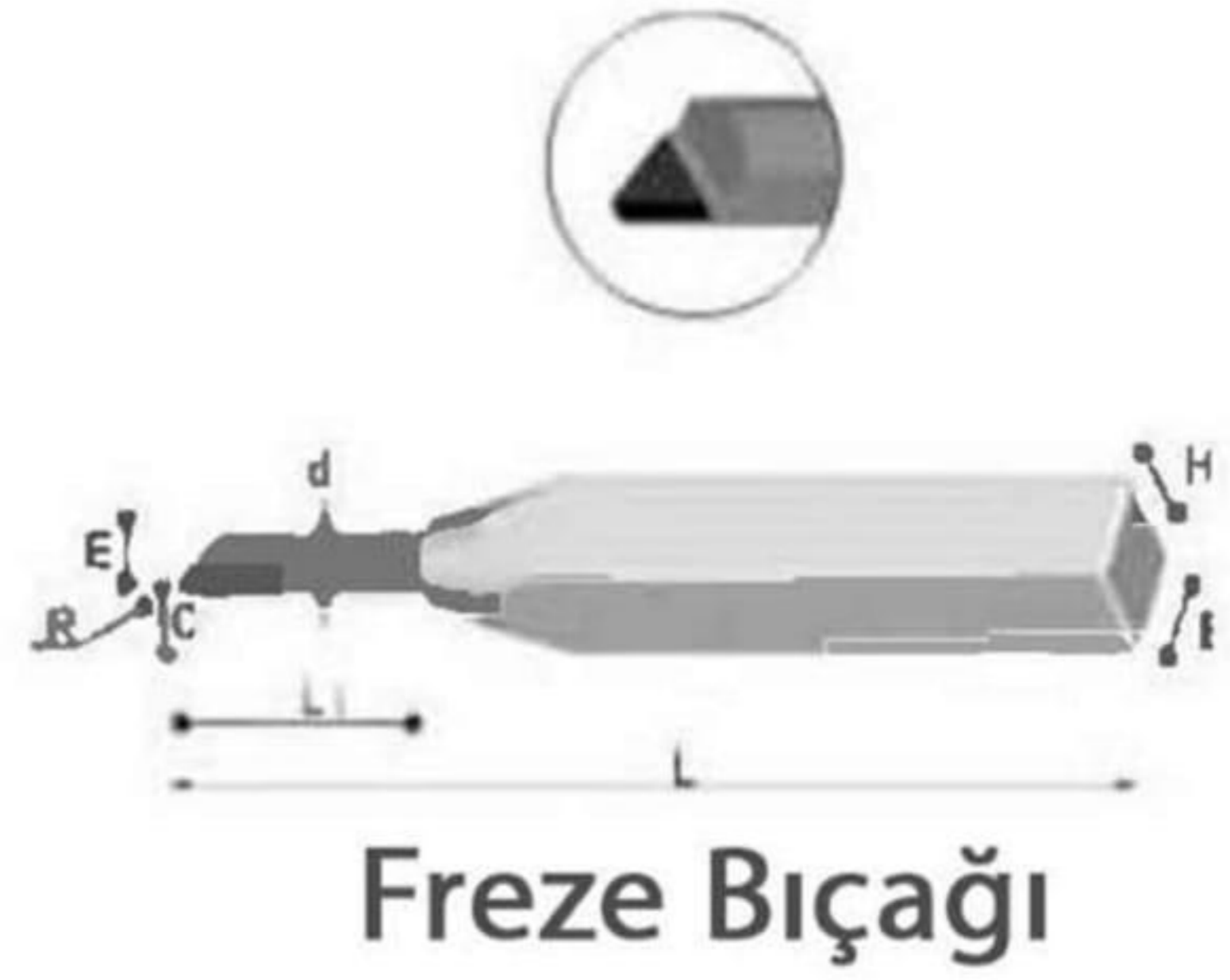

Söktak Elmas Uçlar



NO	Parça No	Özellikler	Açıklama
1	ST006501	20*12*2 (R1/R1.2/R1.5/R2)	
2	ST006502	16*17.5*2	
3	ST006503	16*17*2	
4	ST006504	12.7*12.7*3.2 (R2/R3/R4)	
5	ST006505	35° 28*2.48 VEMN160208	
6	ST006506	35° 28*2.48 VEMN160200	
7	ST006507	35° 38.1*2.5-30°	
8	ST006508	Φ 8.9*1.85-30°	
9	ST006509	Φ 11*4-15°	
10	ST006510	Φ 12*2.5-30°	
11	ST006511	Φ 15*2.5-30°	
12	ST006512	Φ 16*3-30°	
13	ST006613	M4*9	
14	ST006614	M5*12	
15	ST006615	M6*15	
16	ST006616	T15	
17	ST006617	T20	

JMS-6004

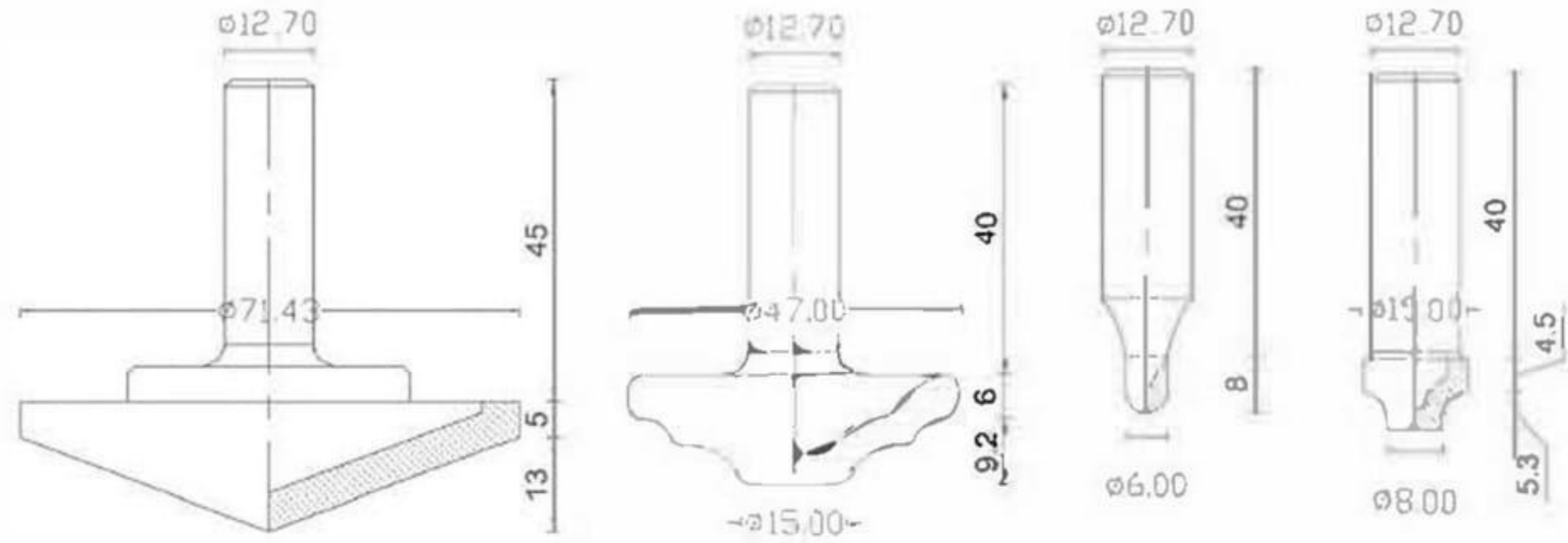
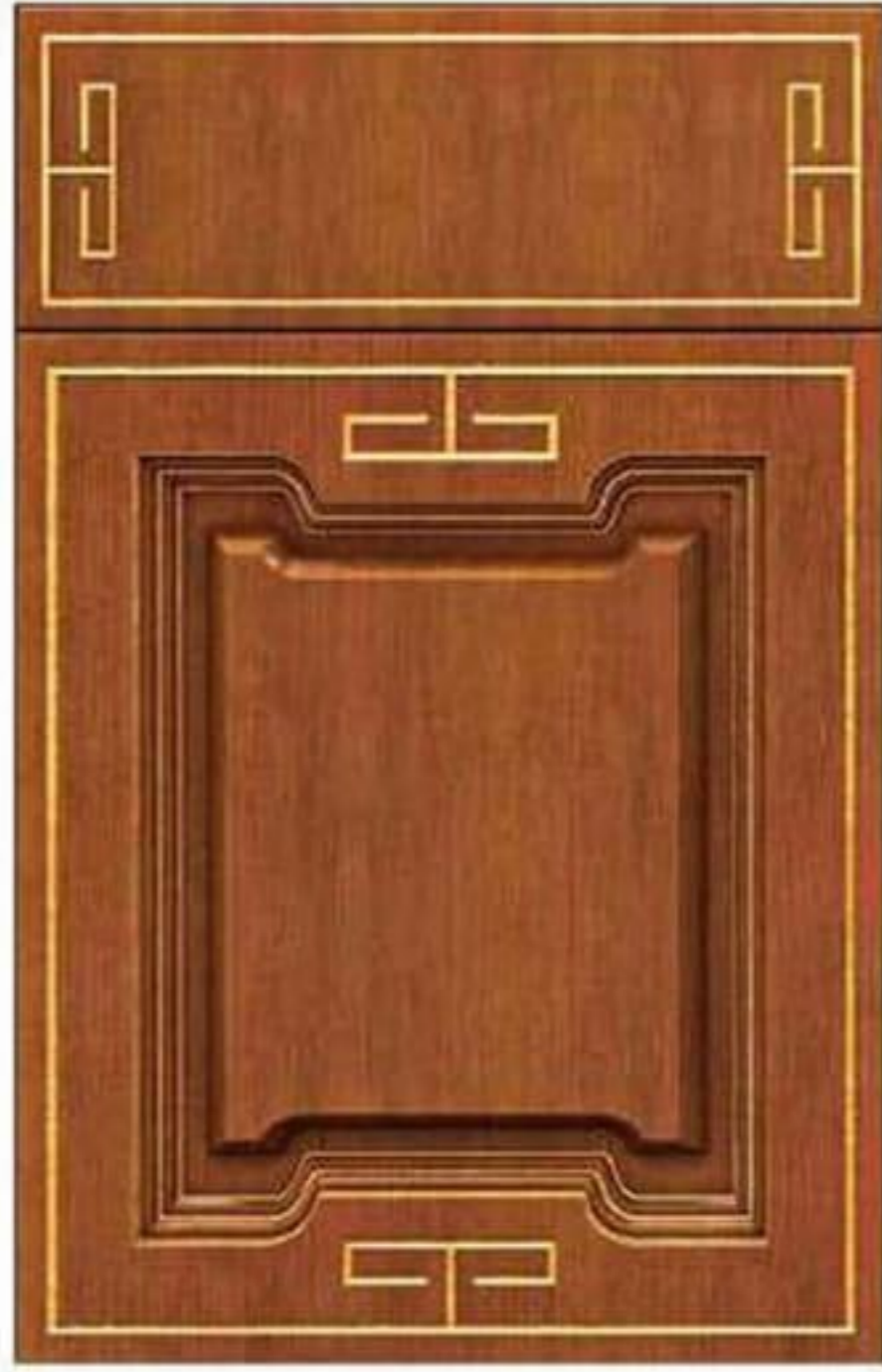

1/1000

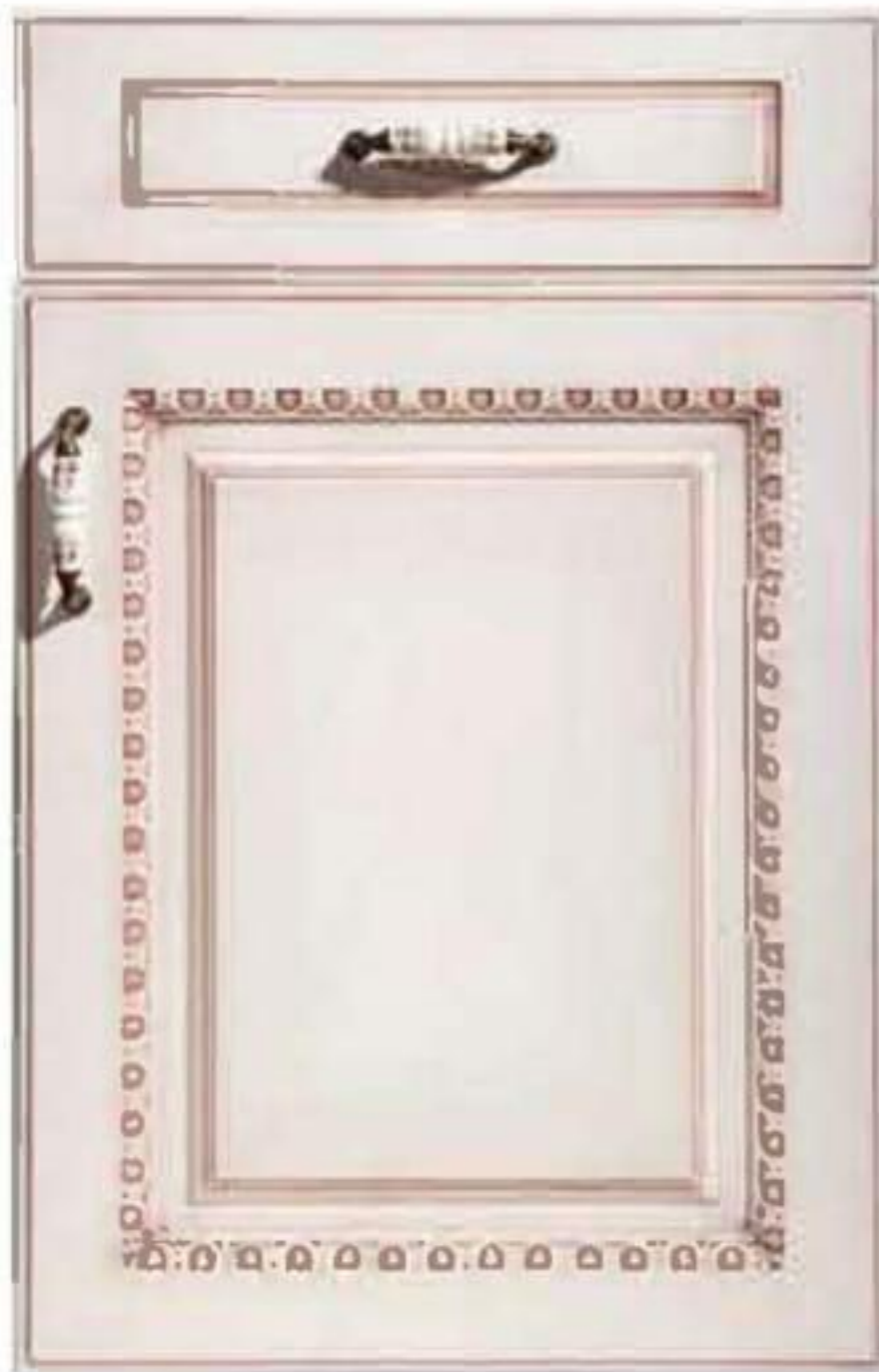

ST117470

ST1174246

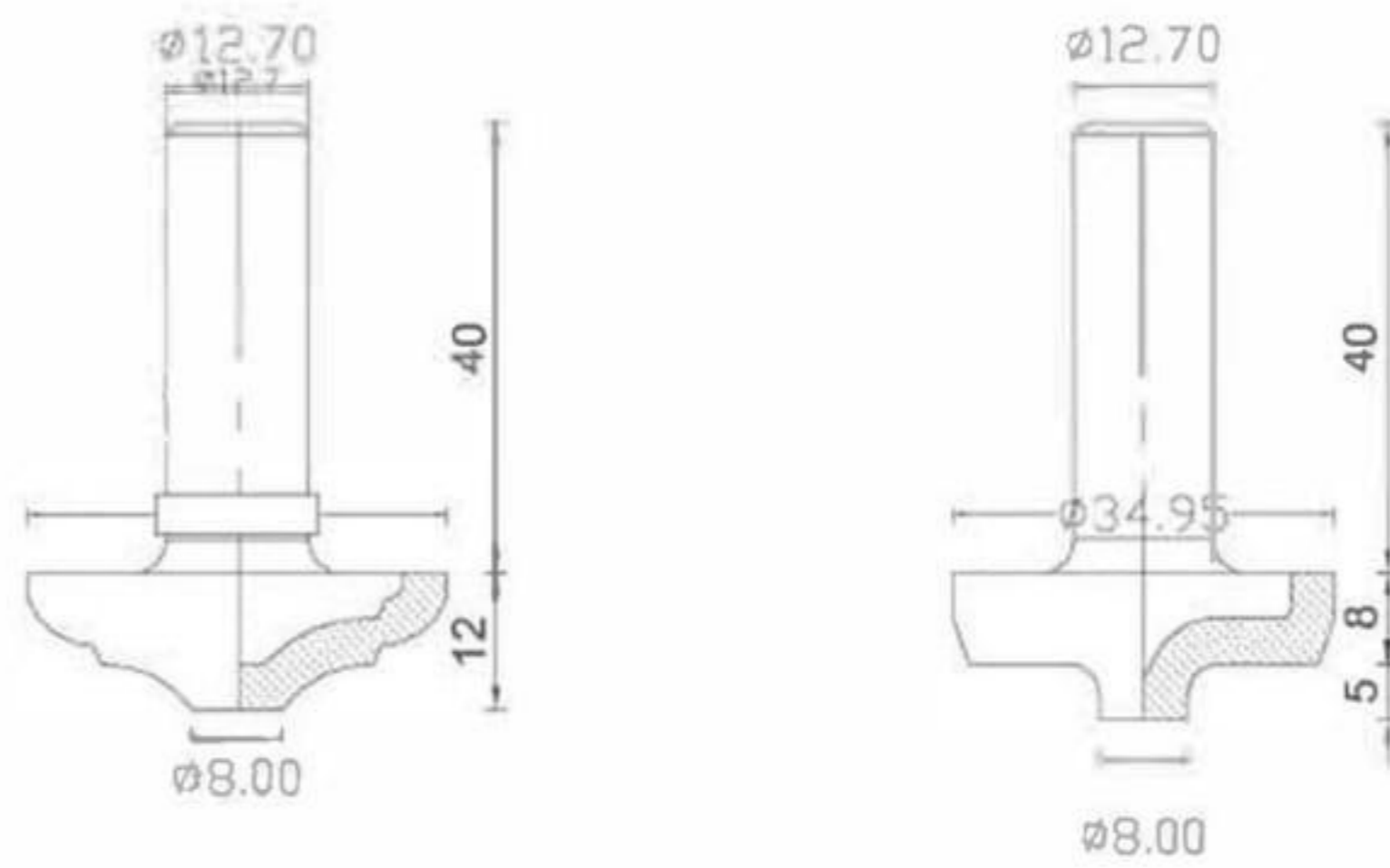

1/1000

JMS-6008



ST100133

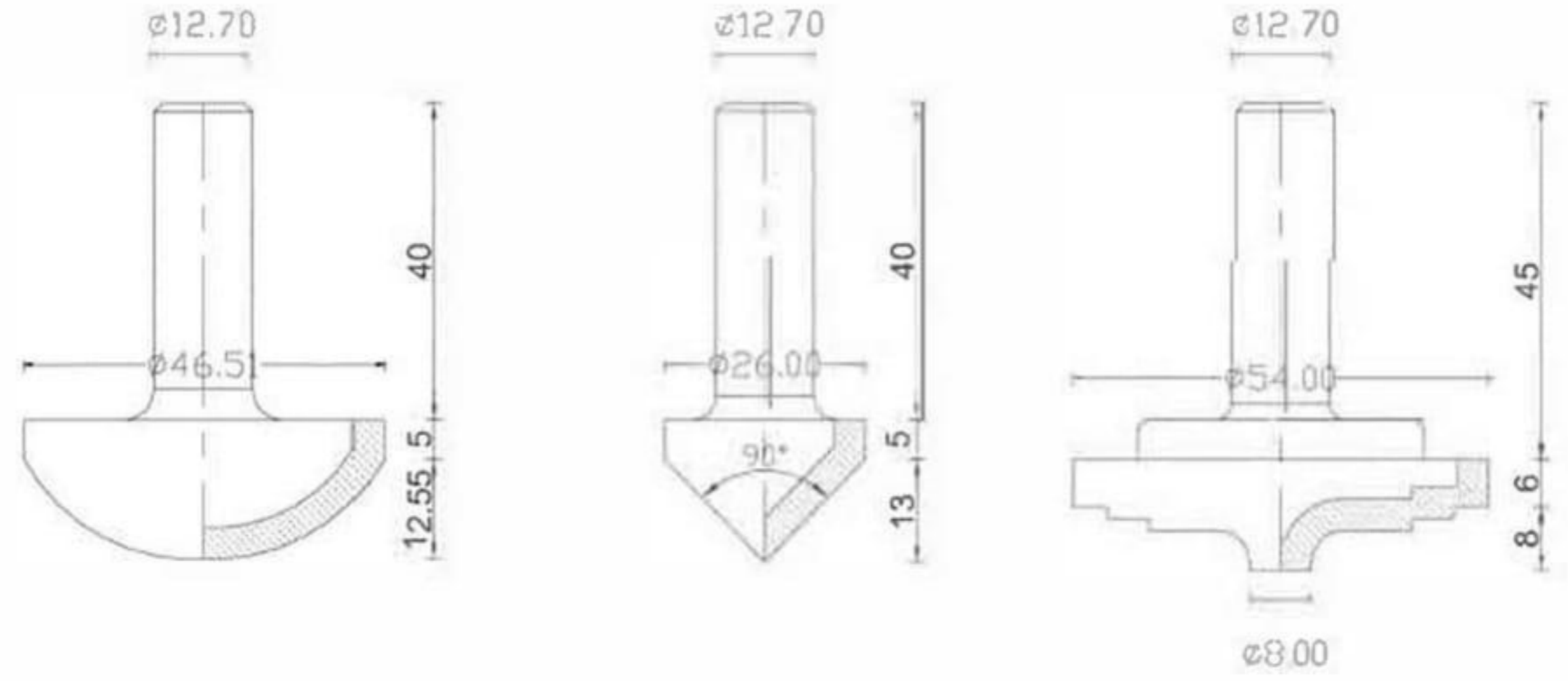

JMS-6040



ST1174362

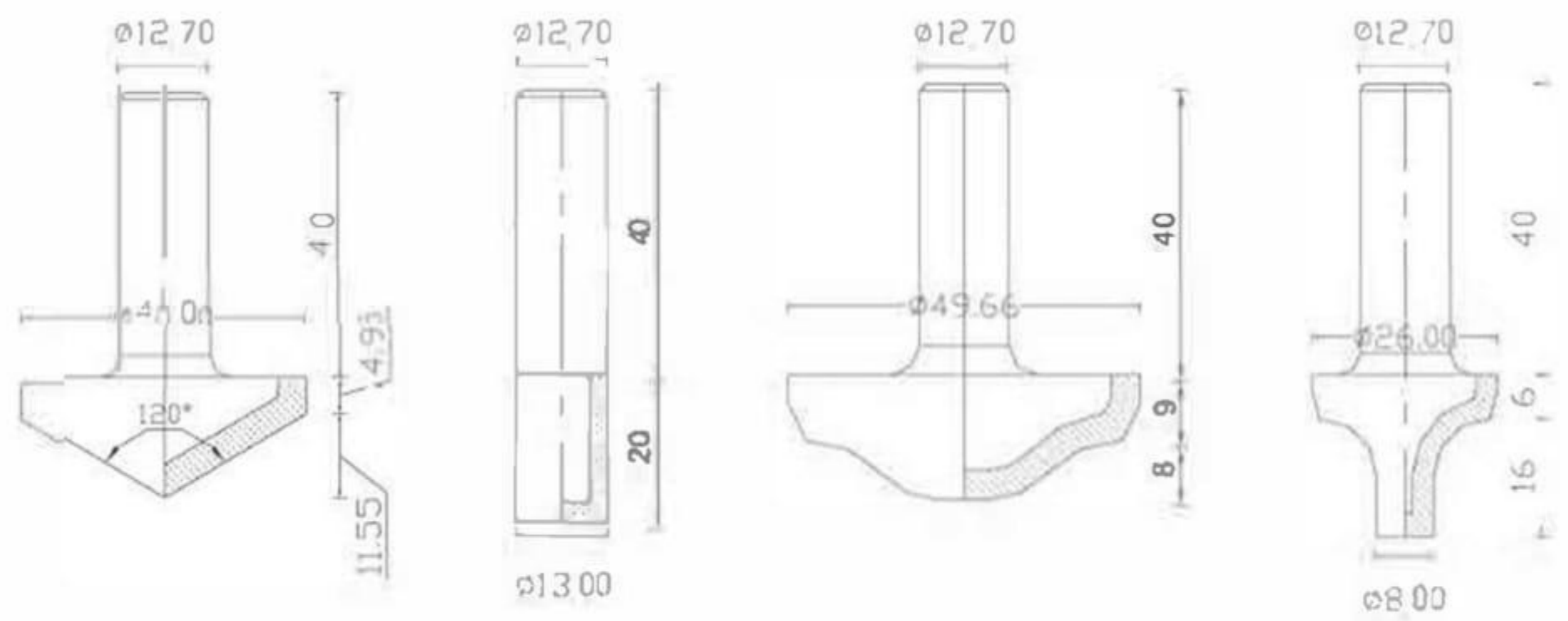



ST115903

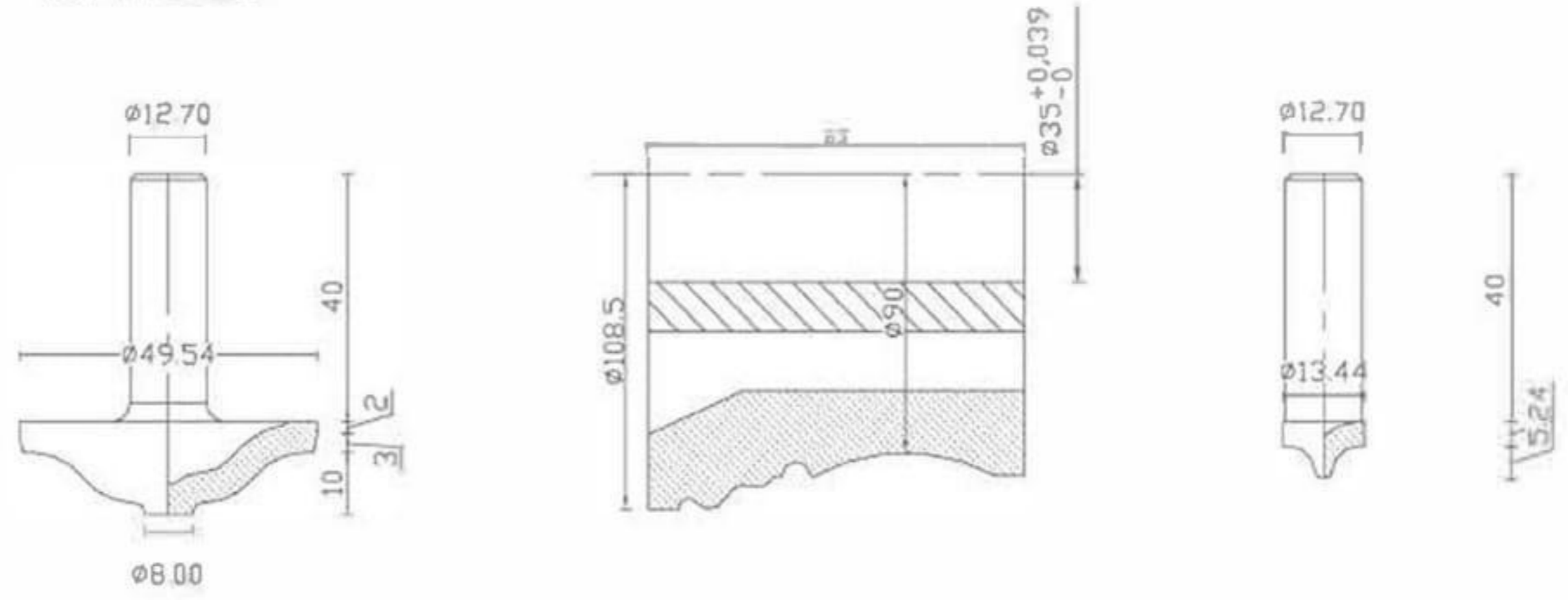

ST1174230

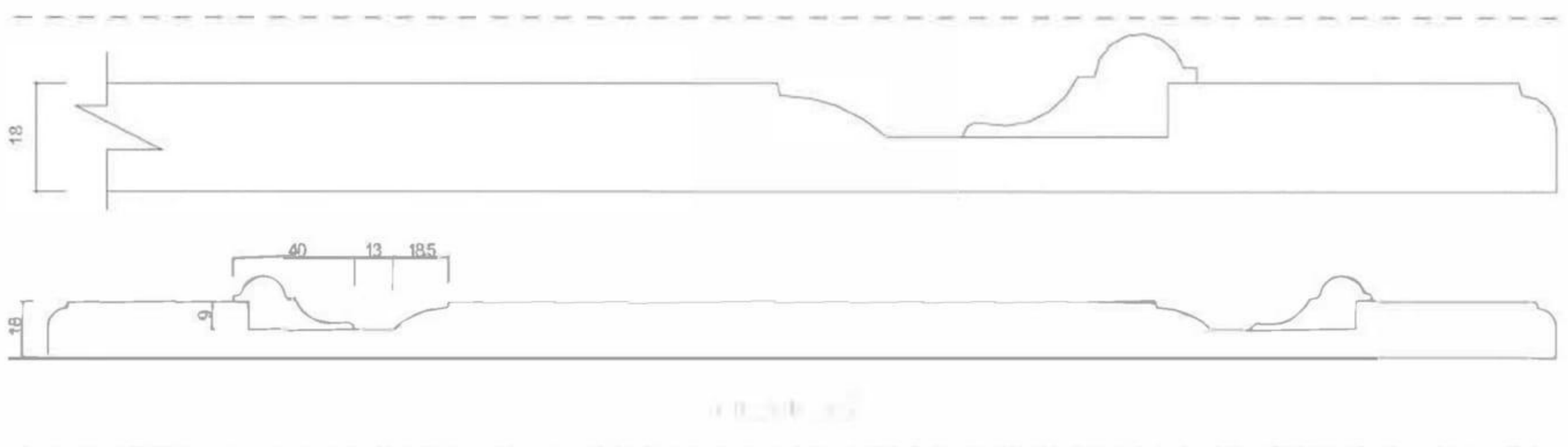
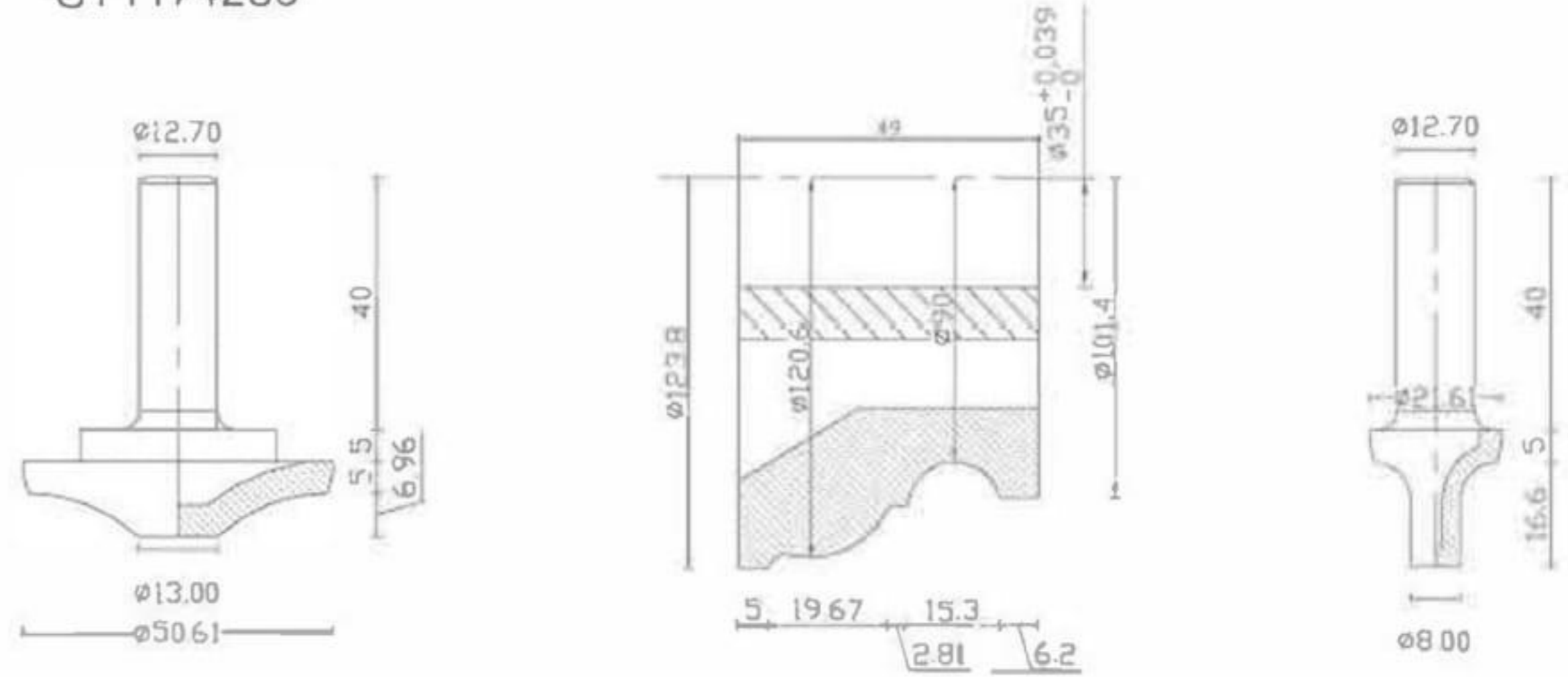

JMS-6053



ST1174530

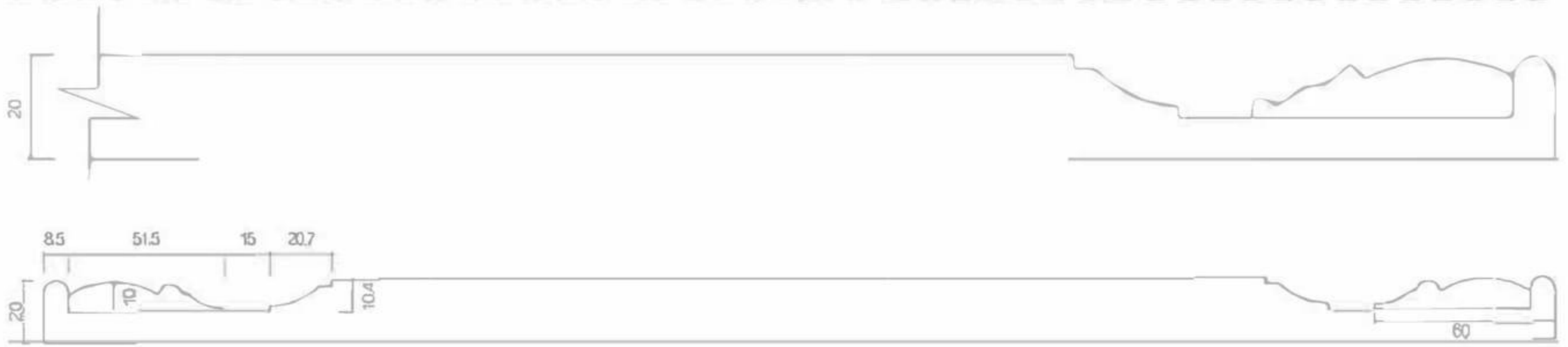
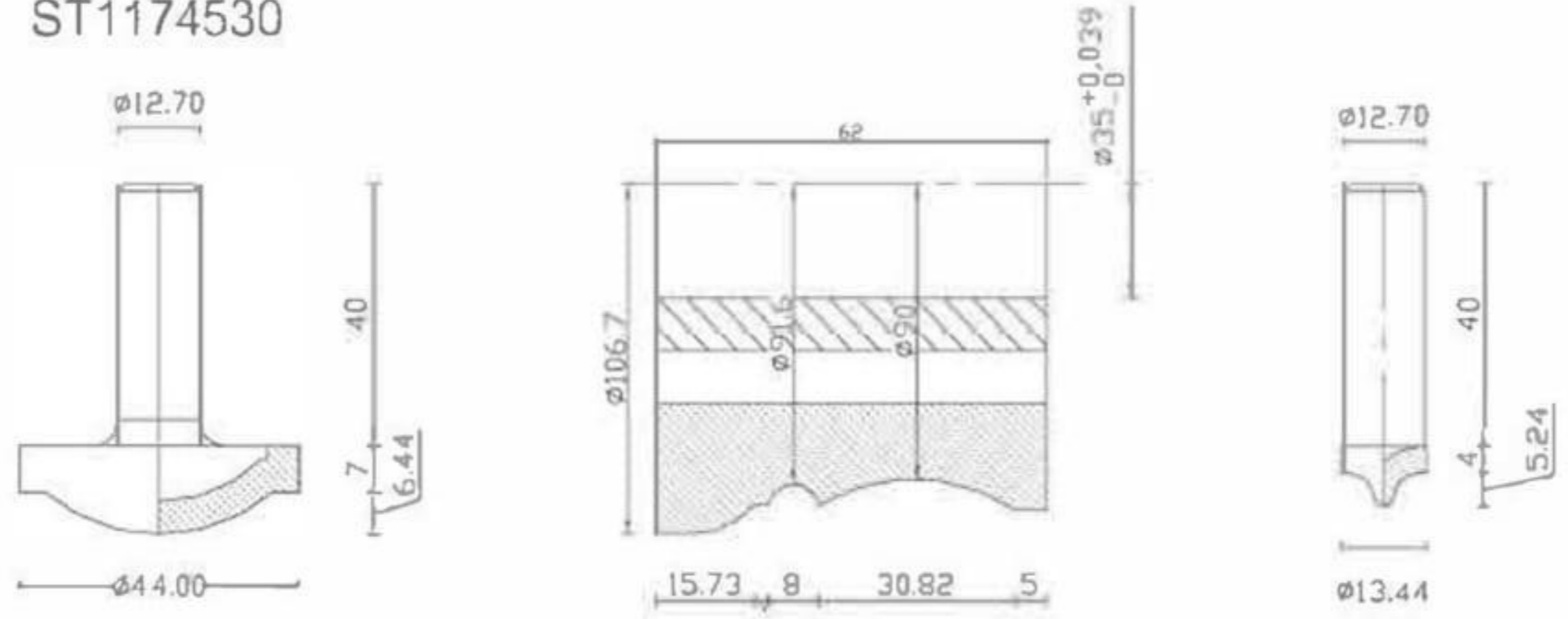

ST100133

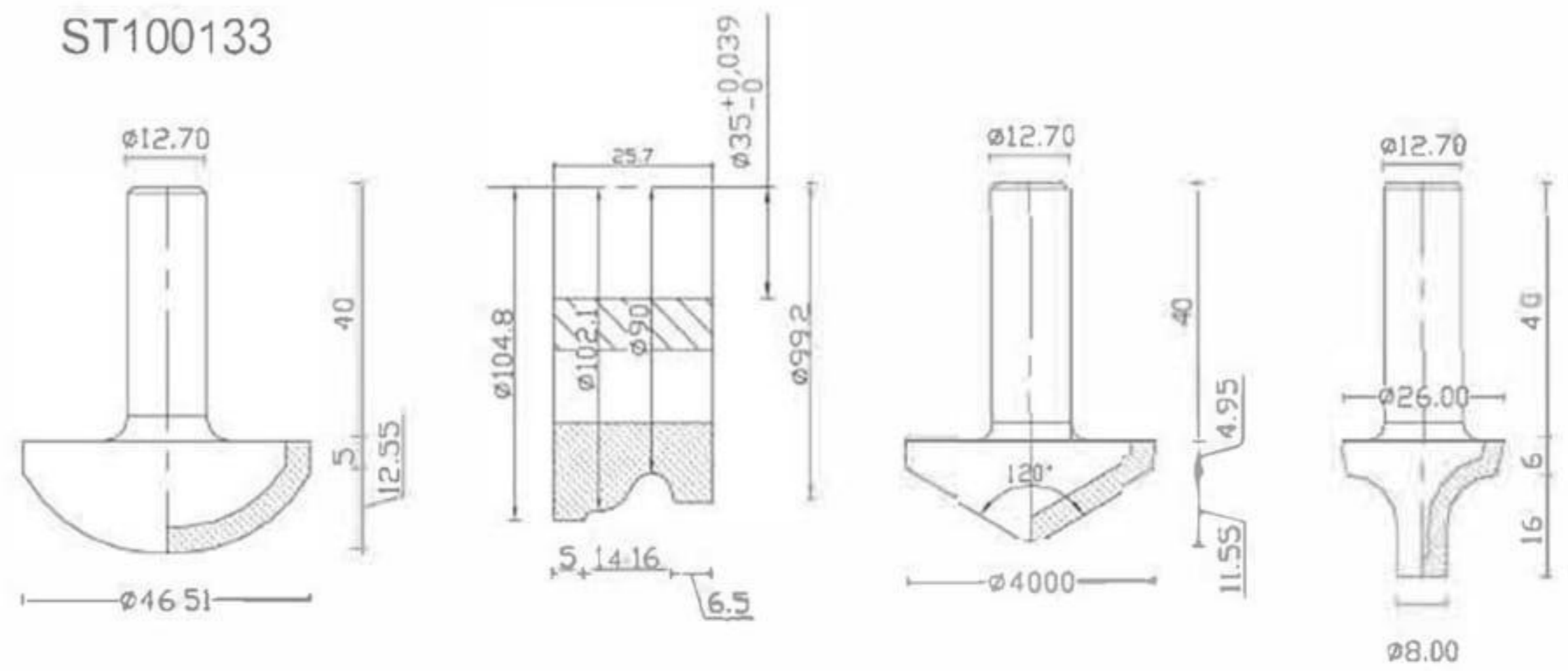

JMS-6116

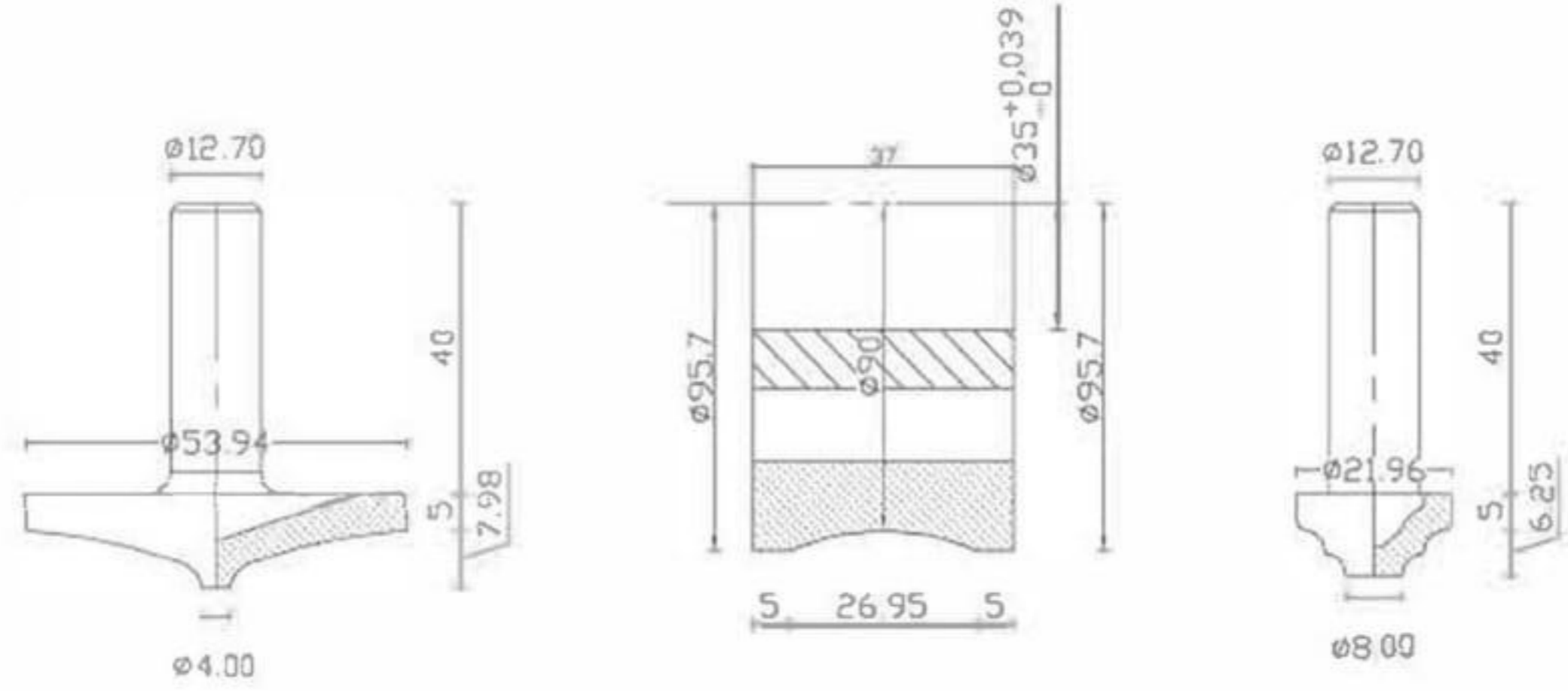

JMS-3058

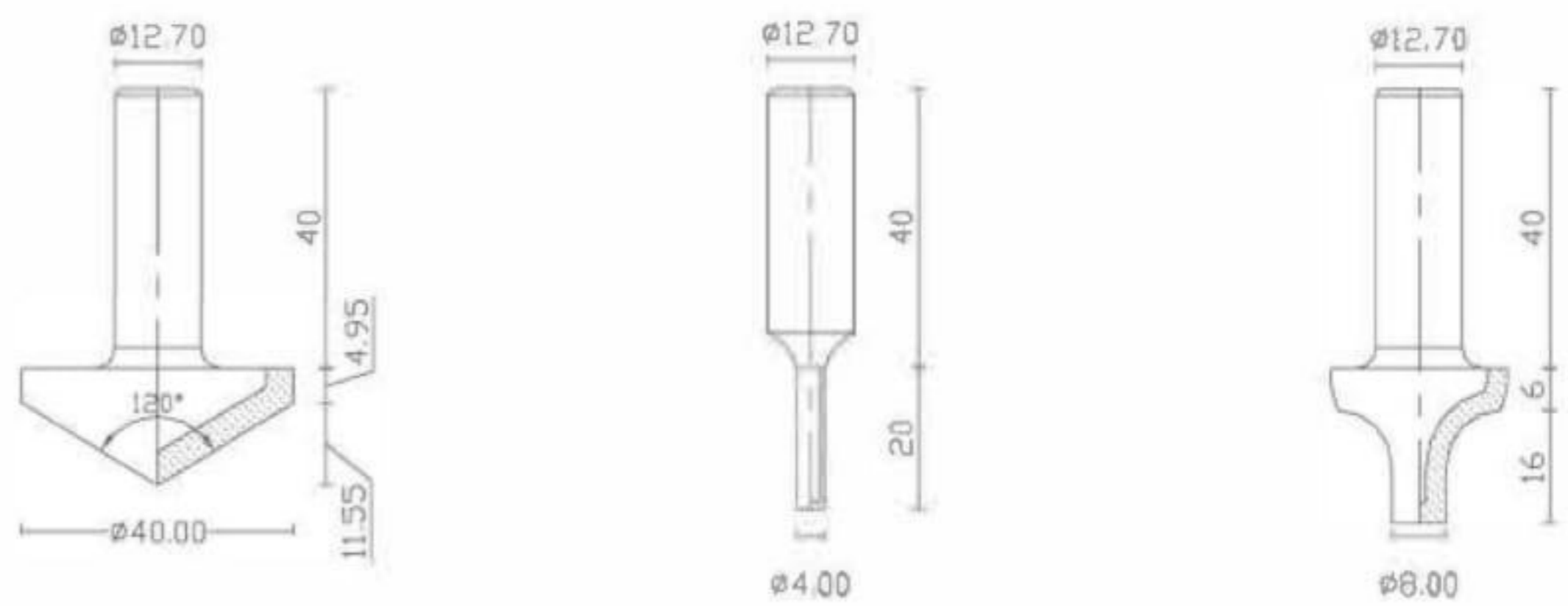

JMS-6116



ST1174505

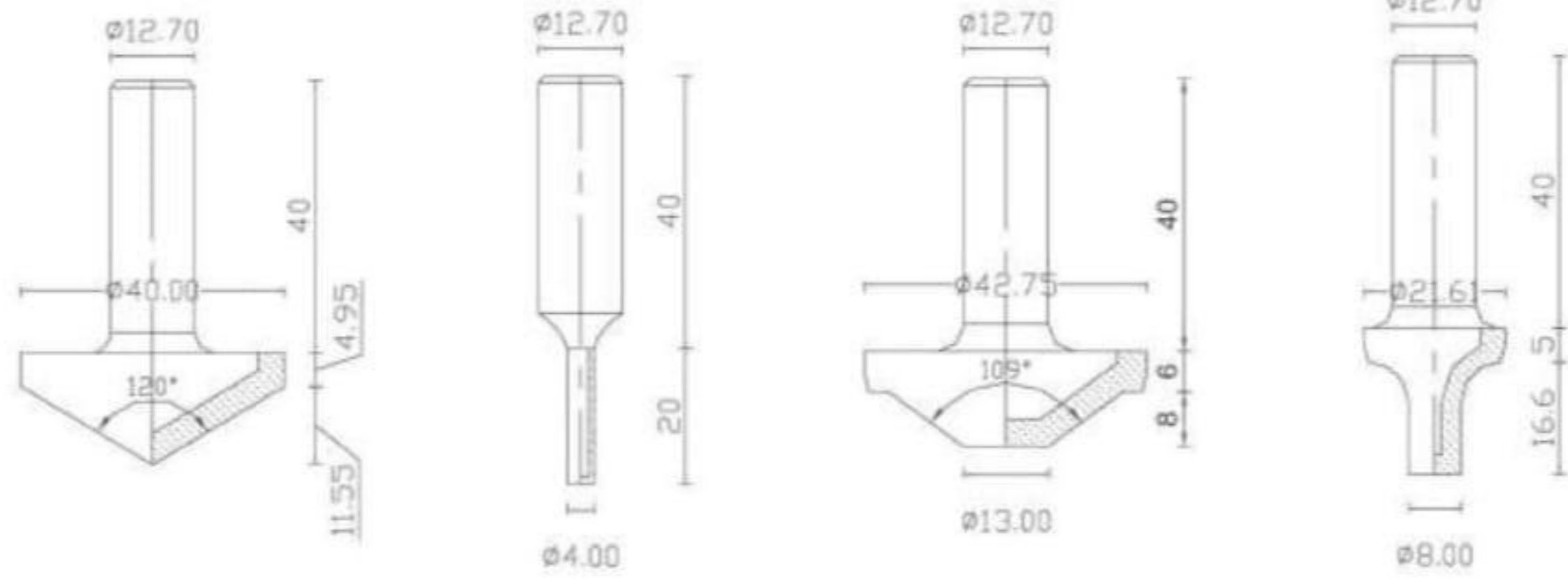

JMS-3058

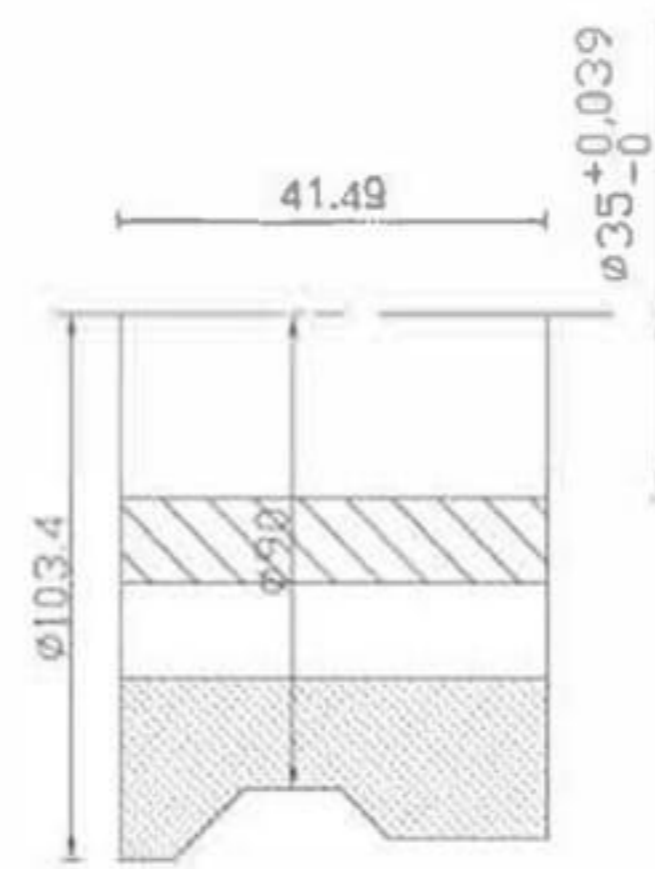

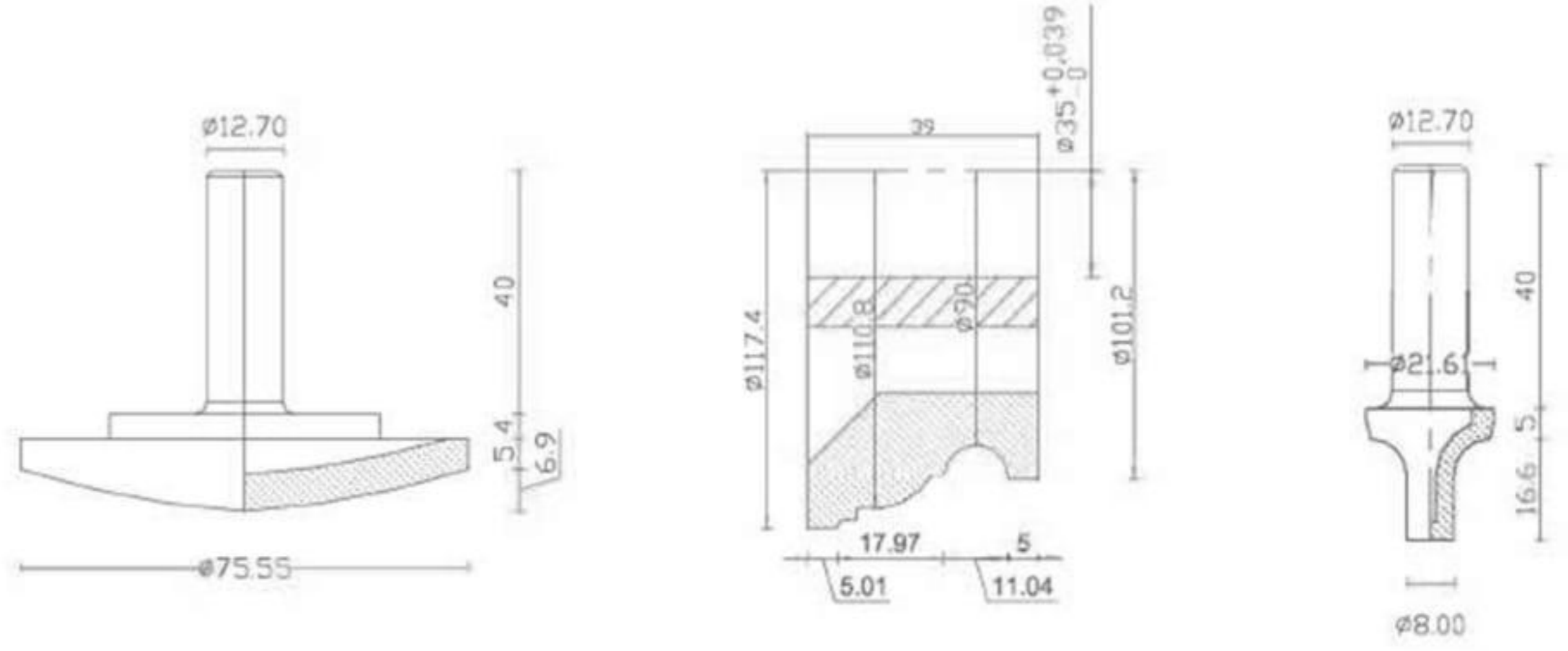

ST1174230

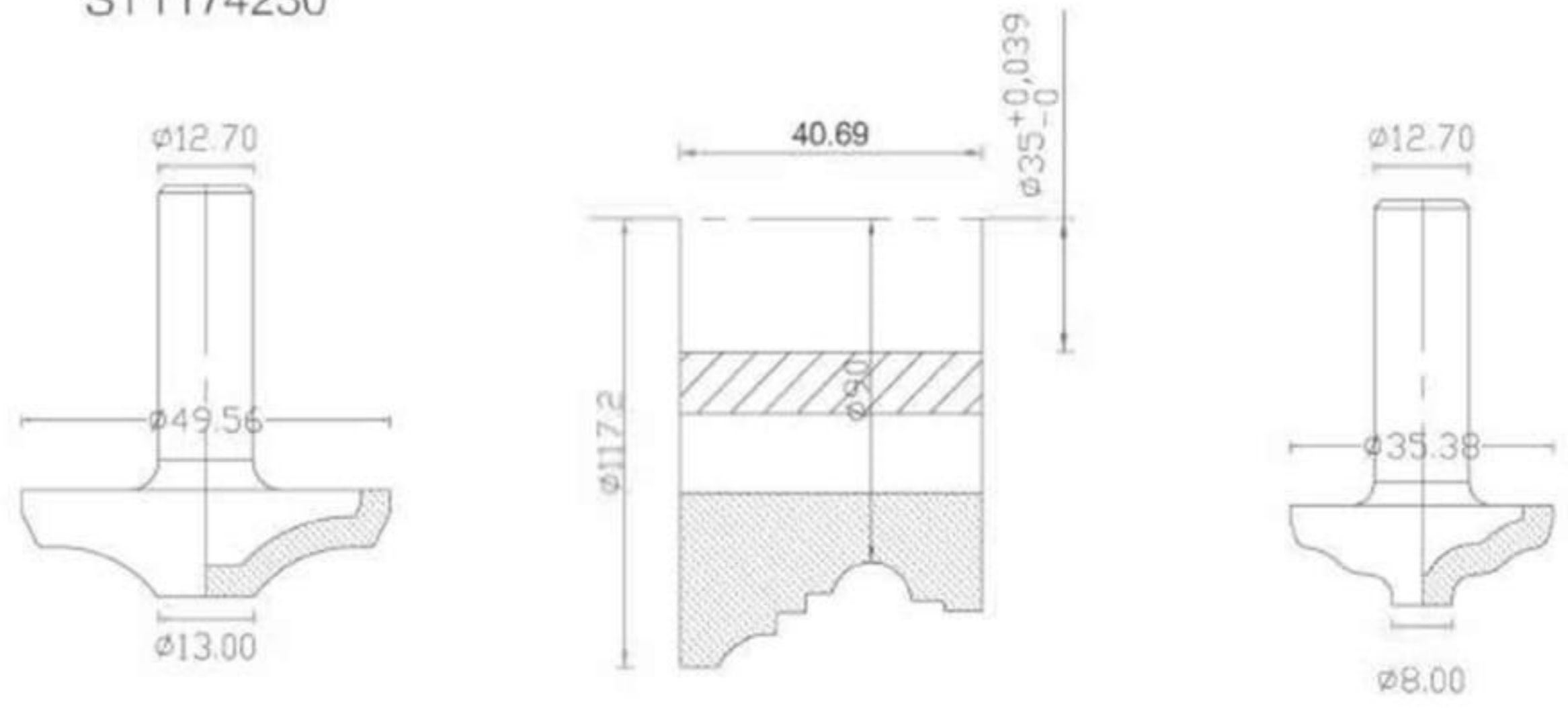



ST1174505

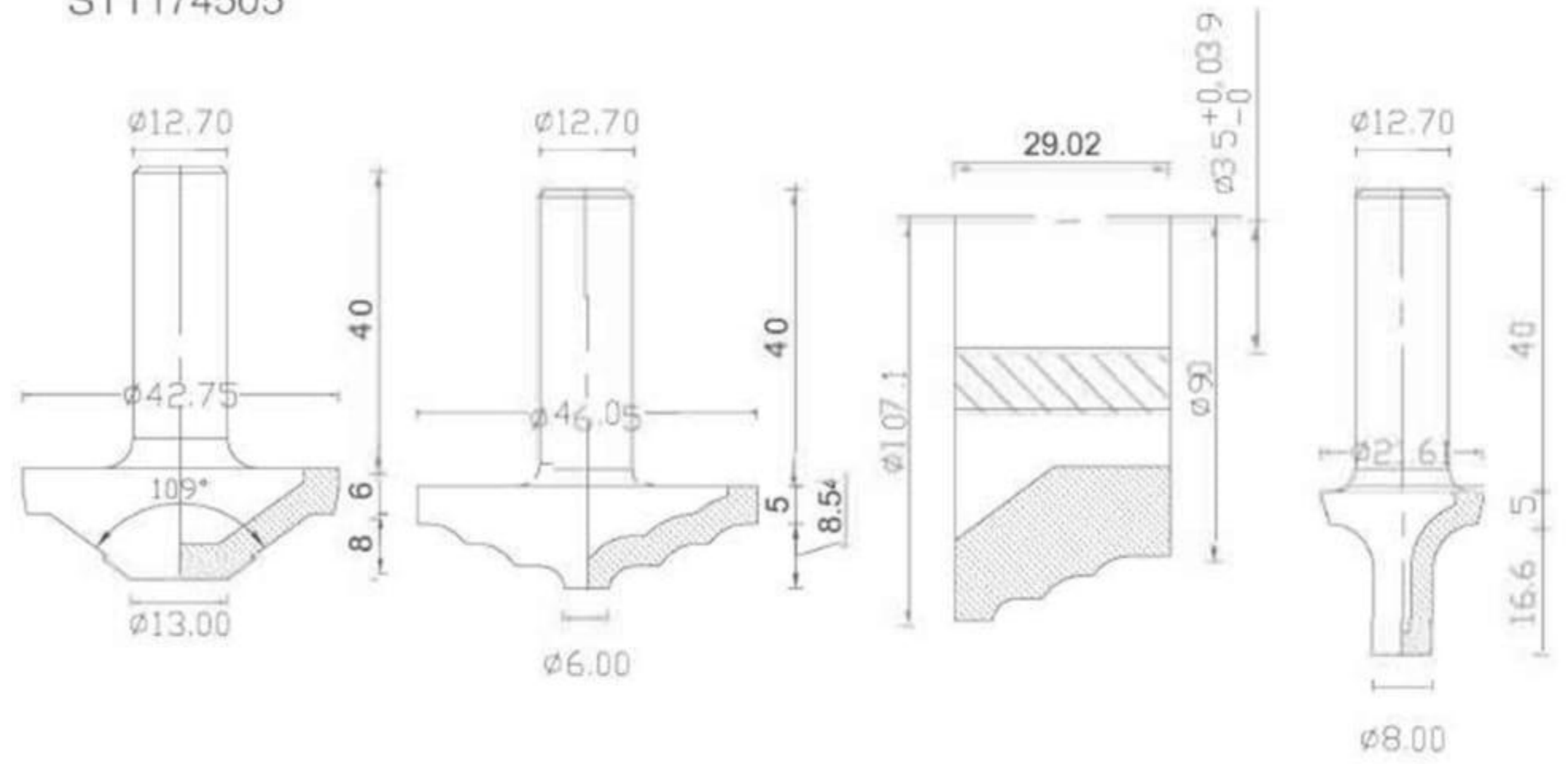

ST1174230

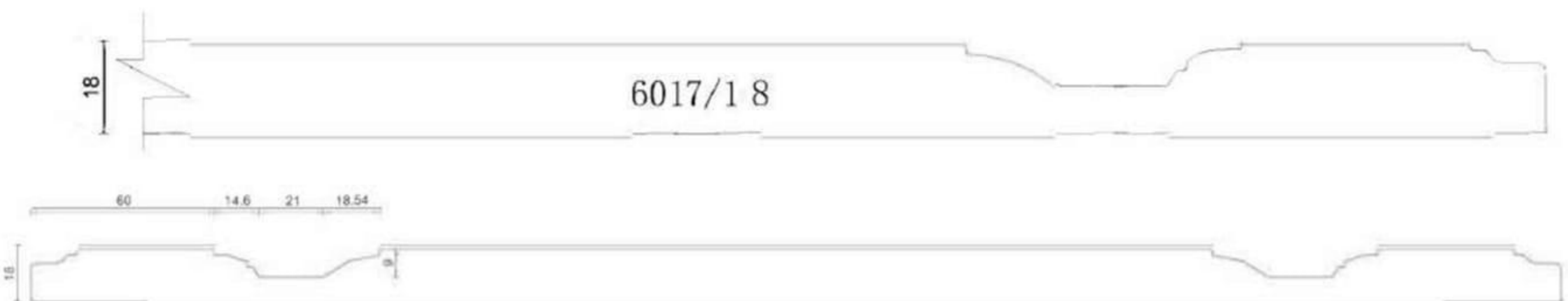
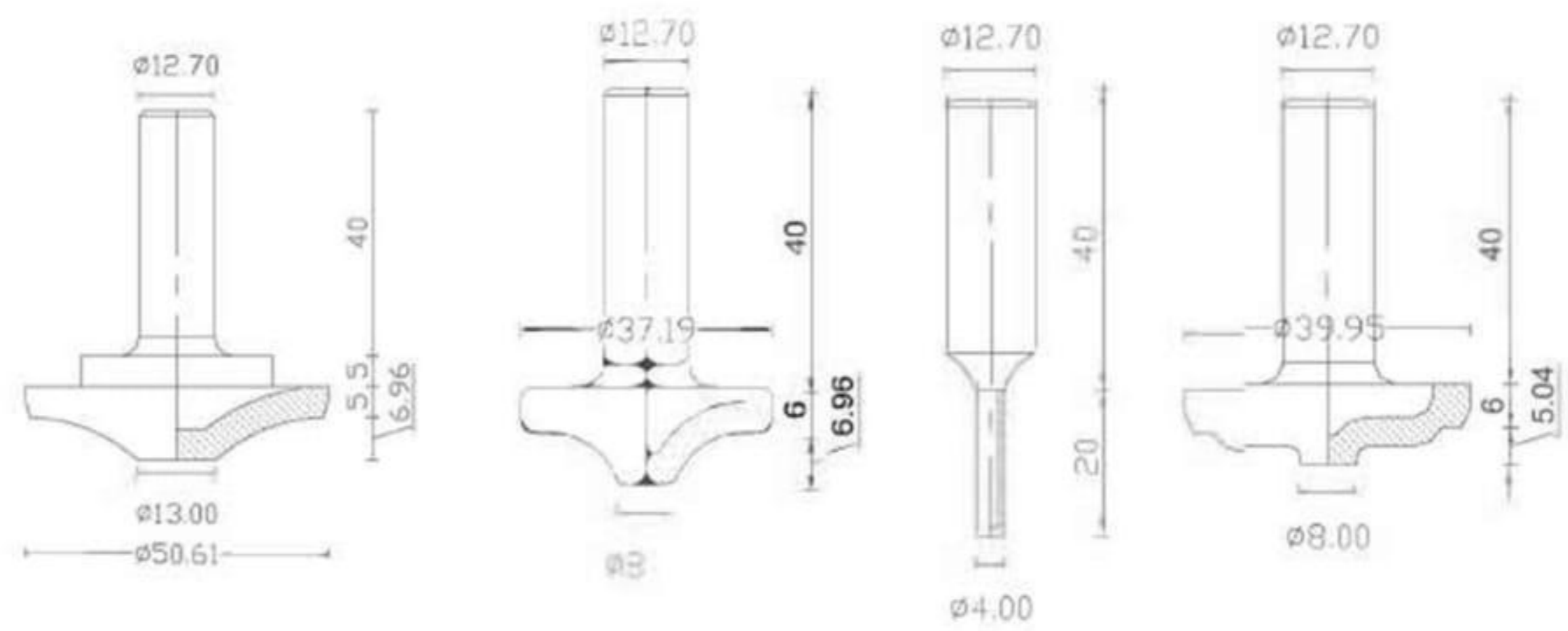

6017/1 8



ST100133

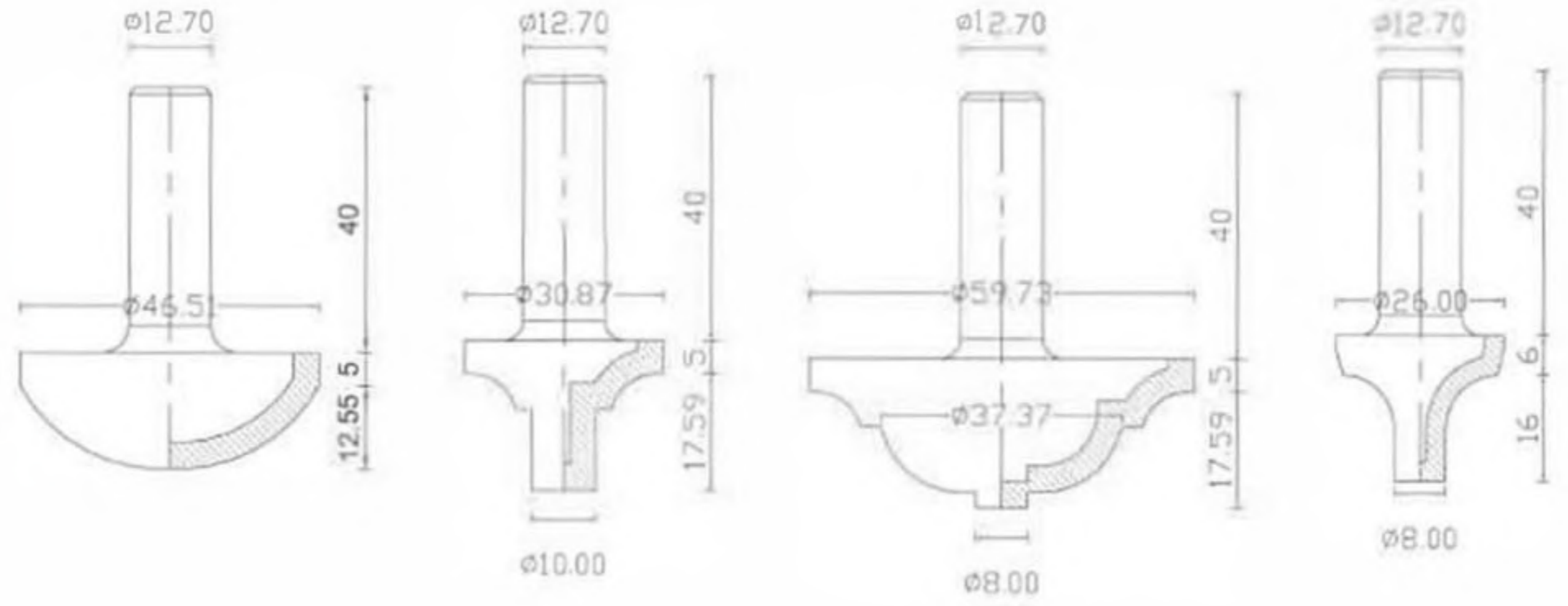

ST1174246

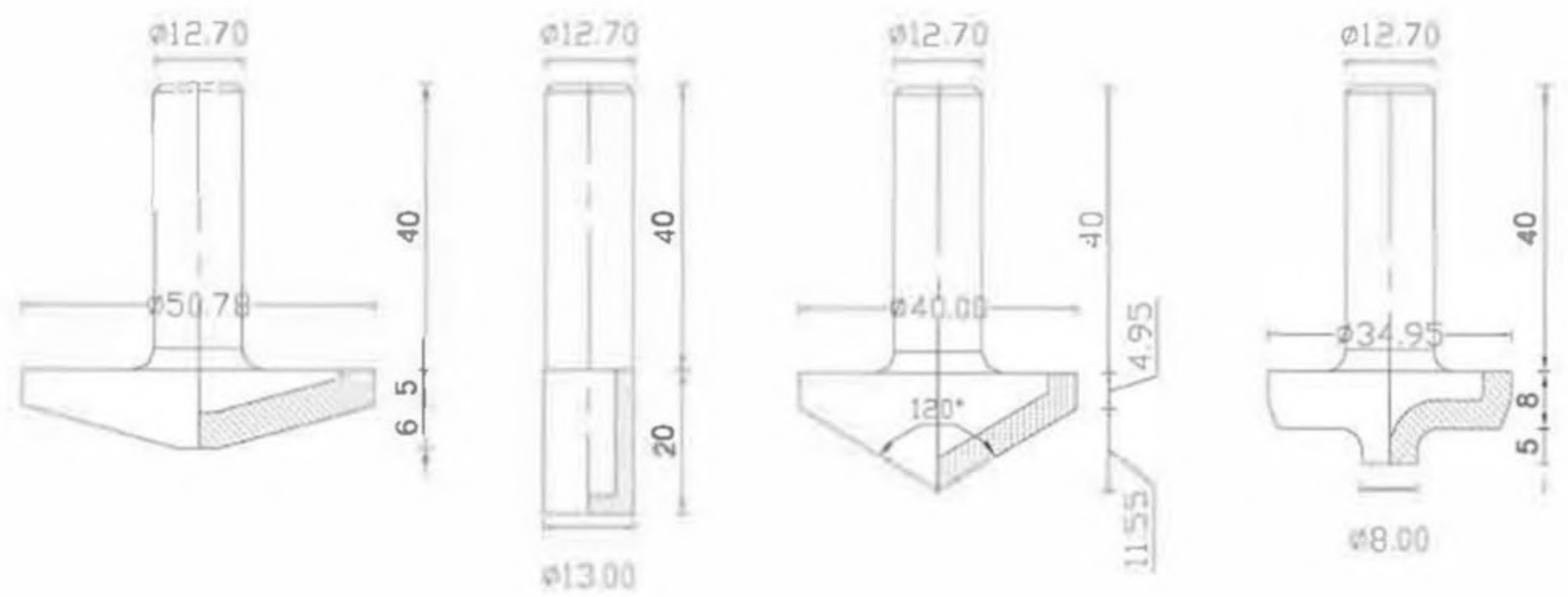



ST127534

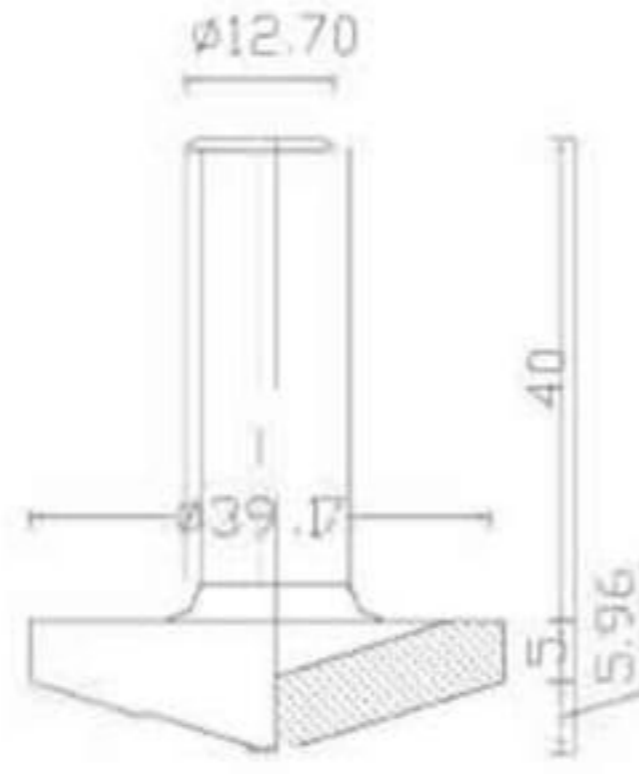

ST127535

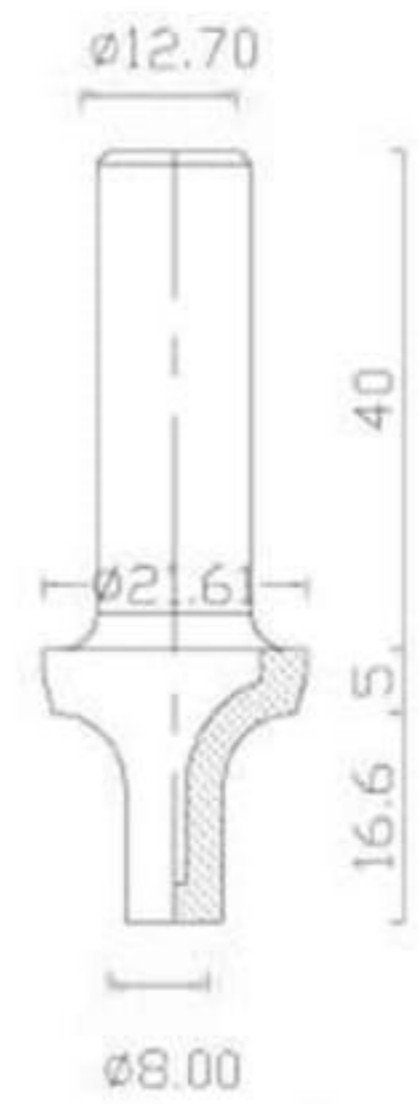
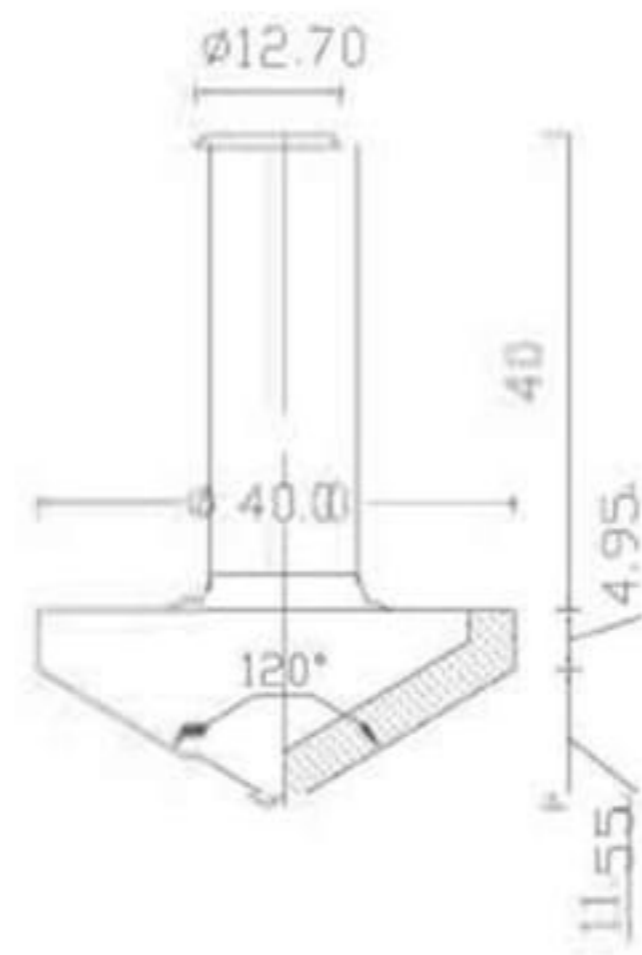
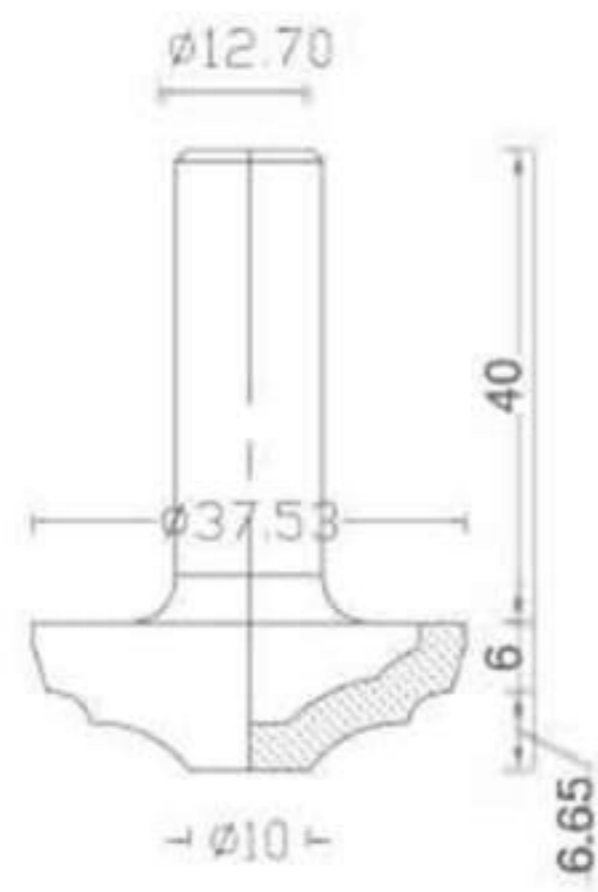
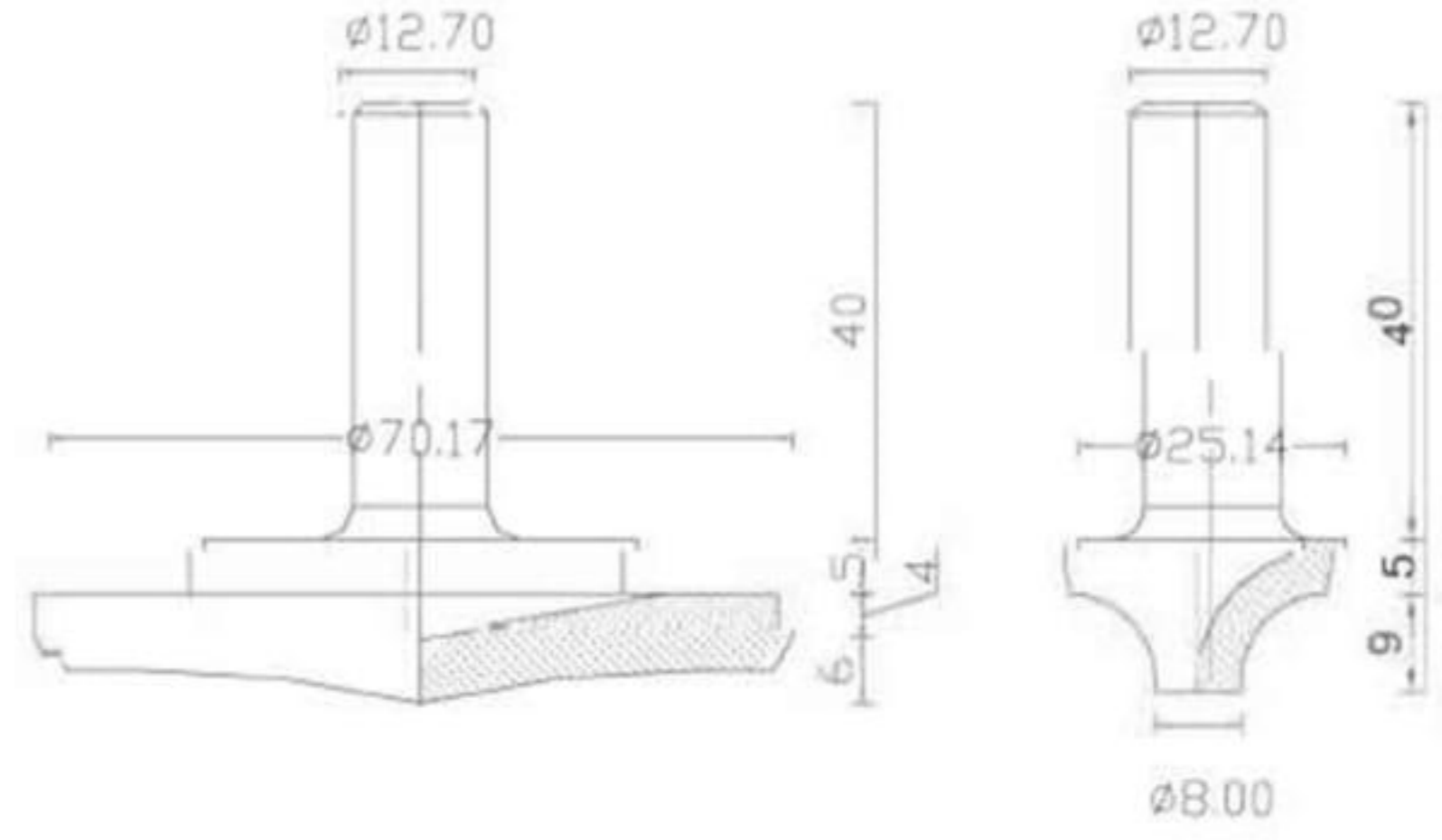



ST117470

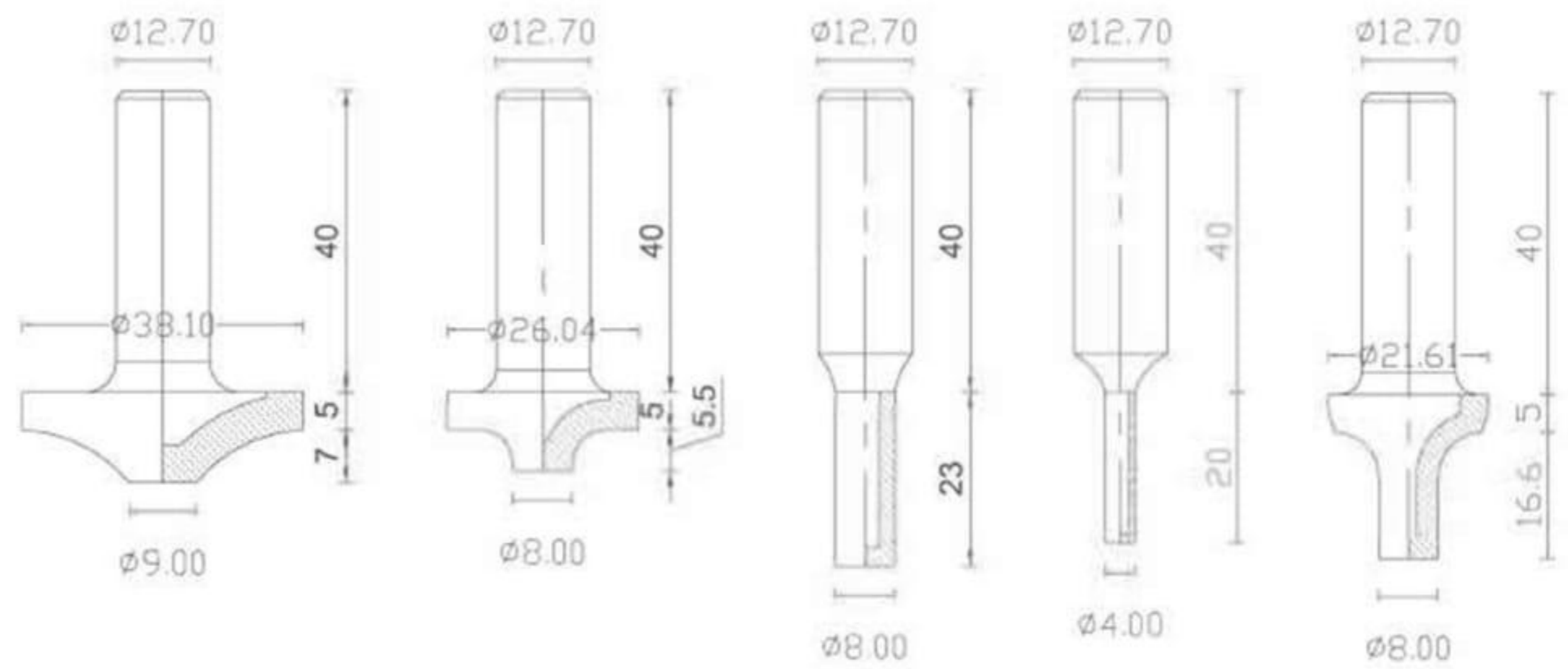
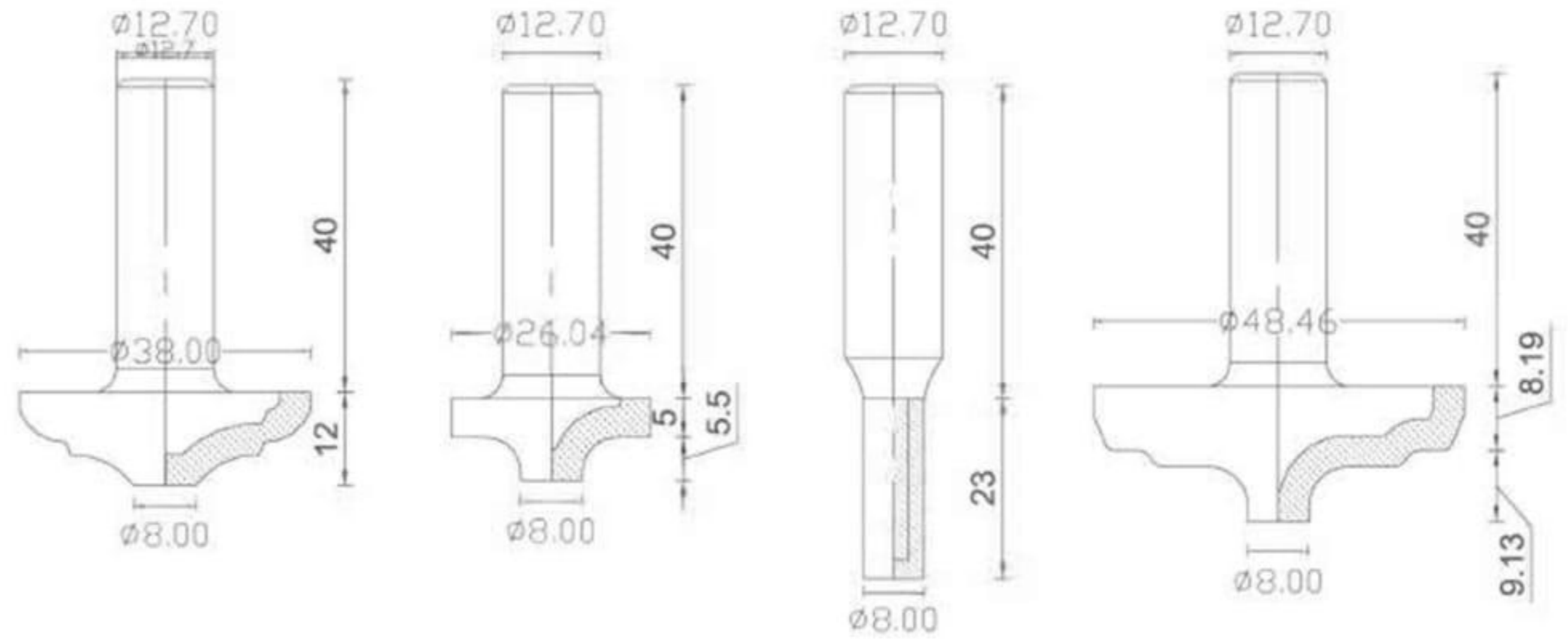

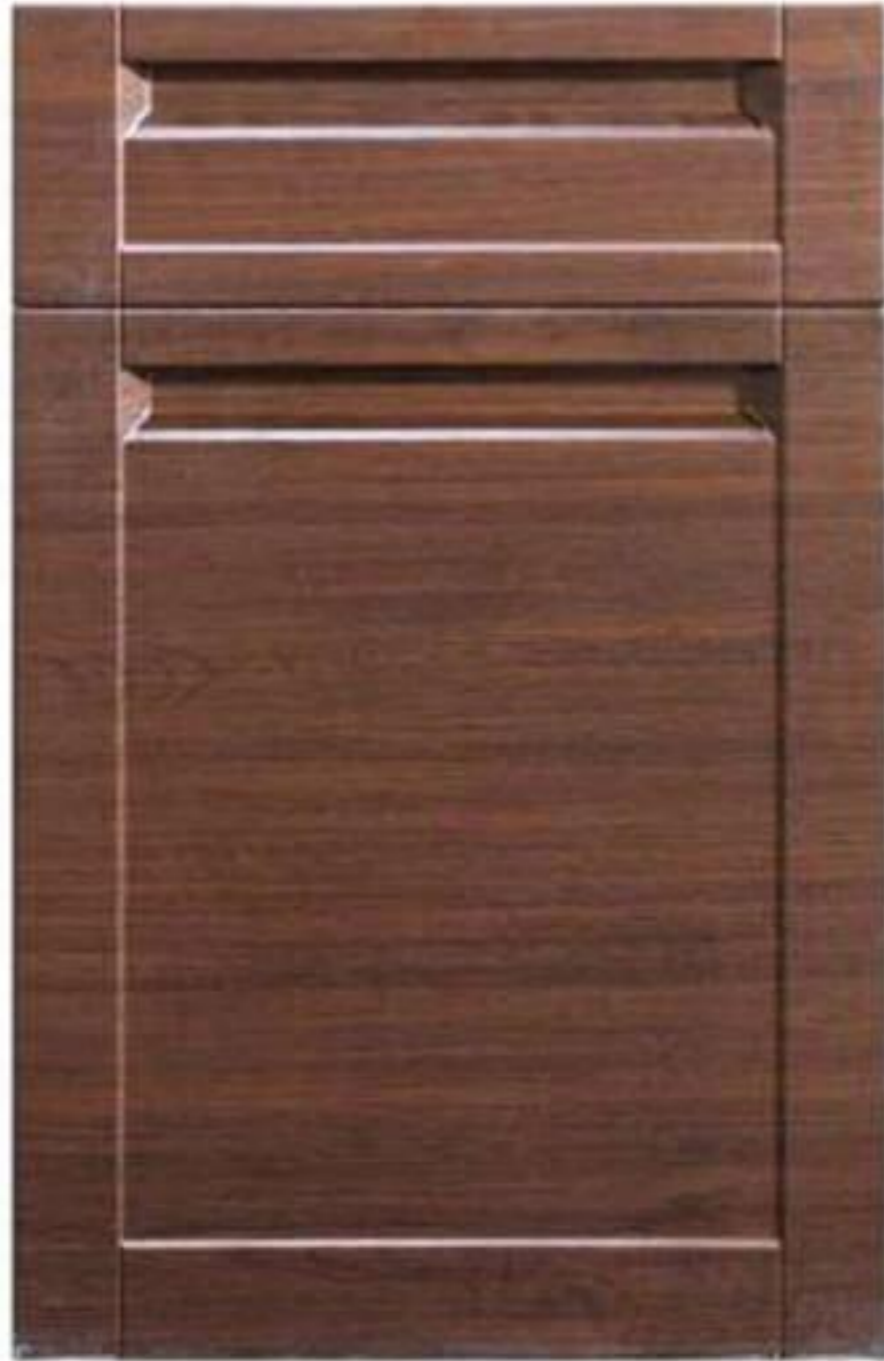

ST1174398

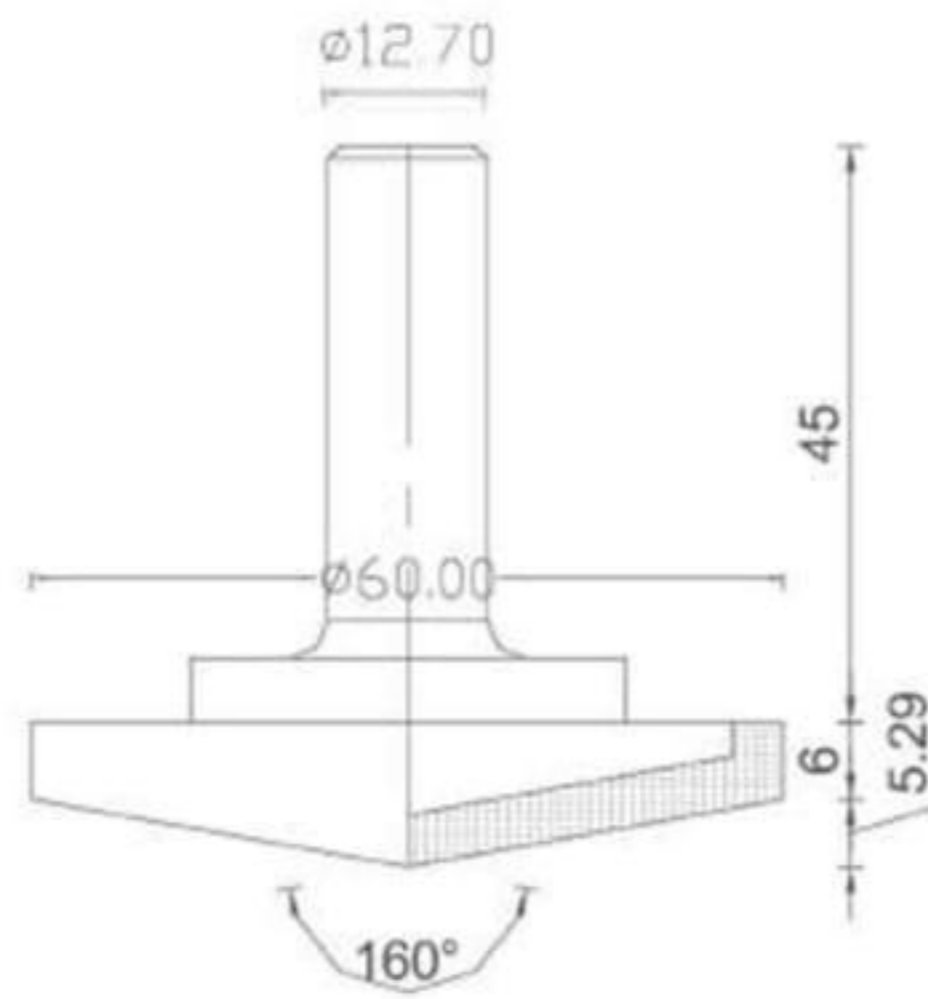
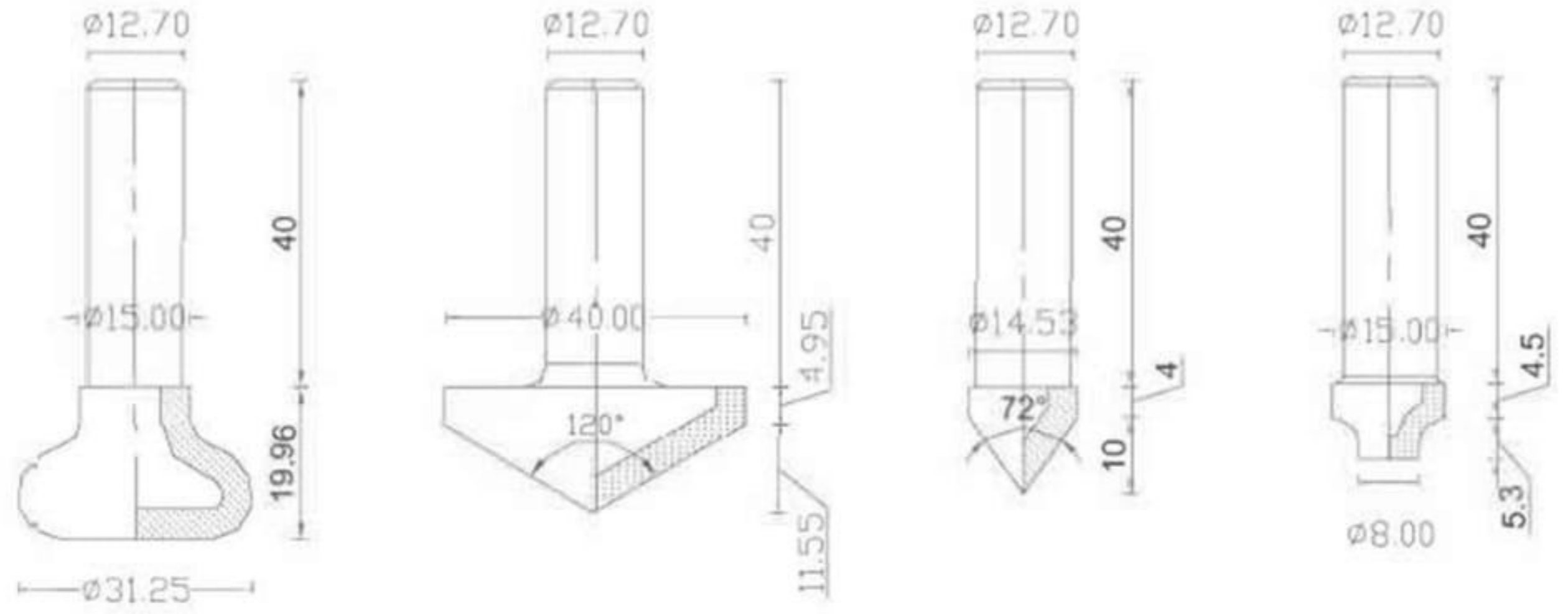



ST1174530

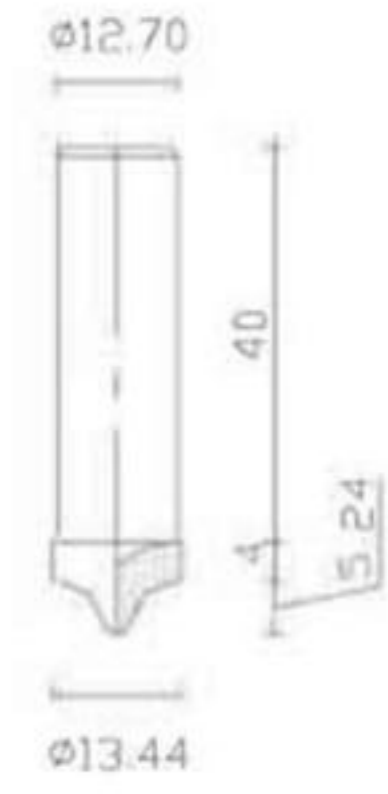
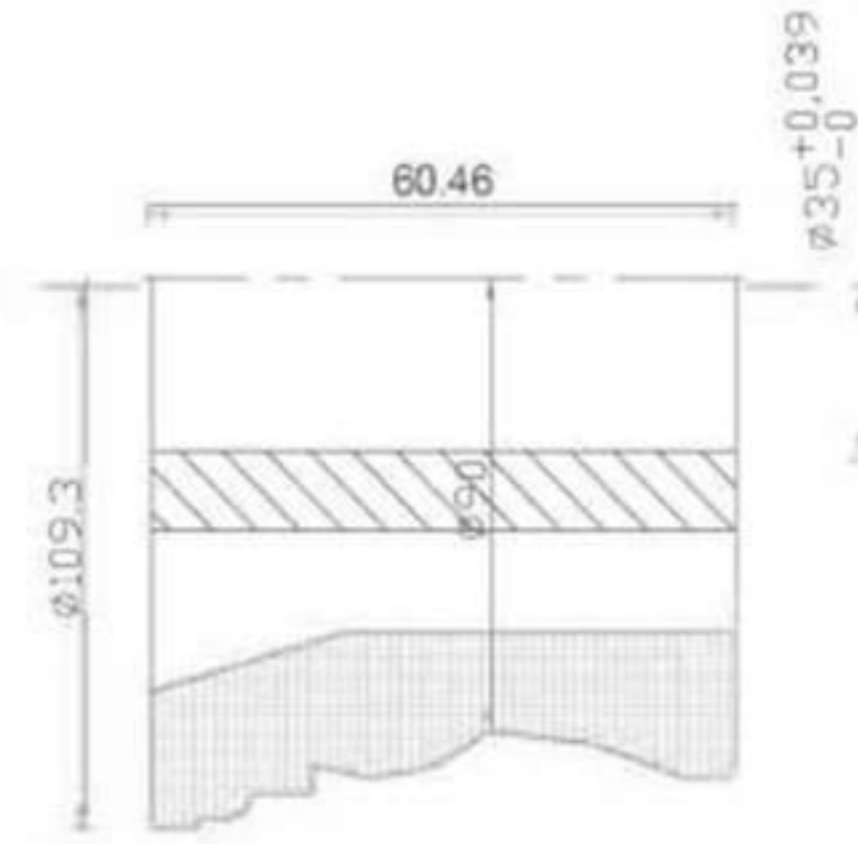
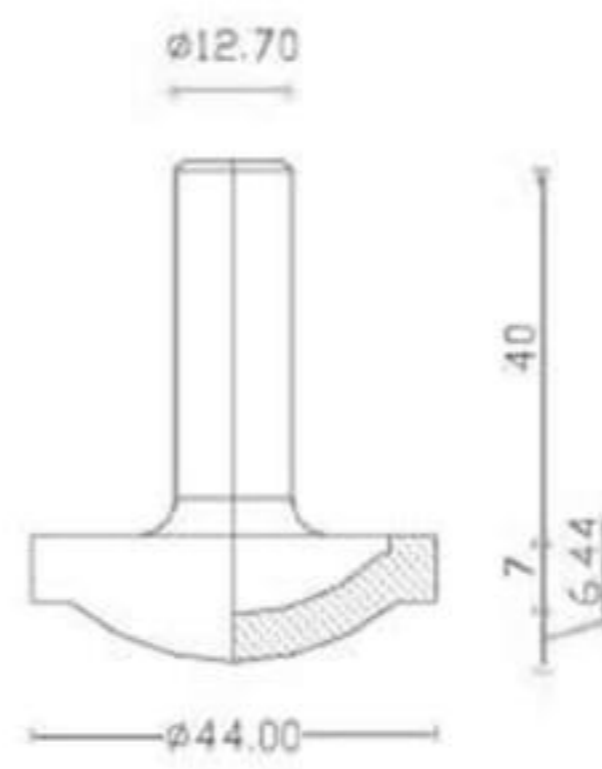

ST100133

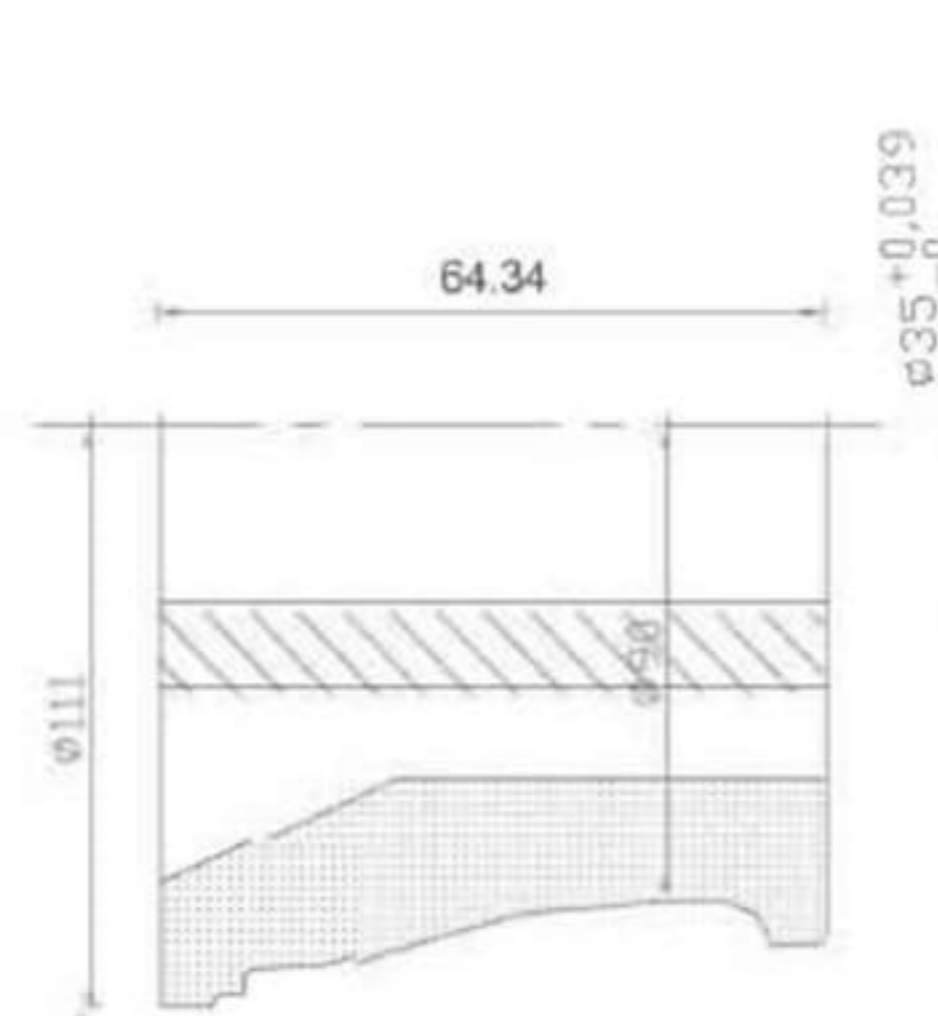
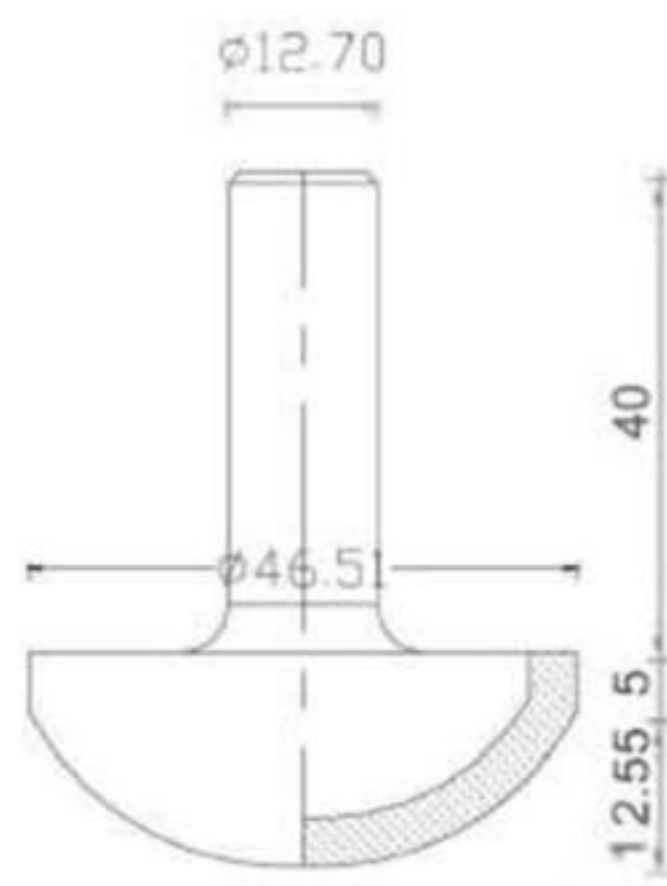



ST115903

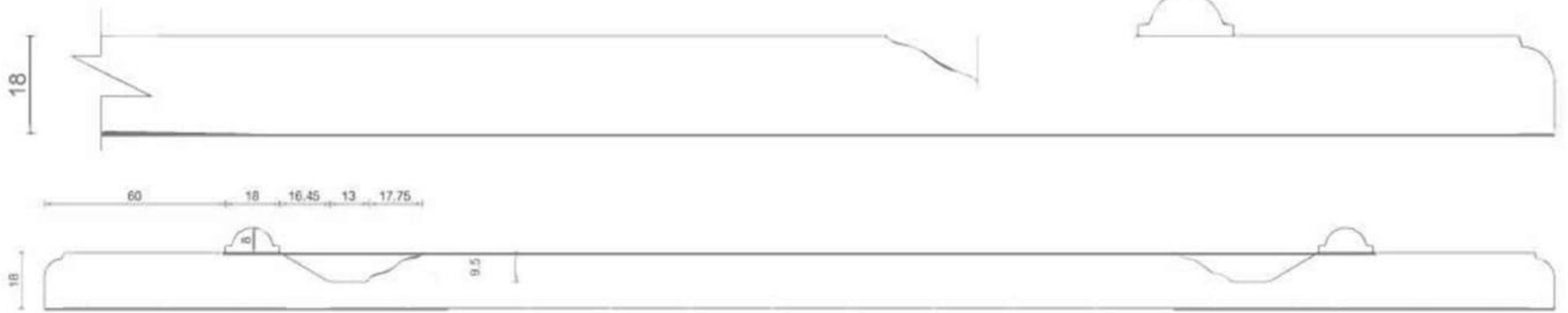
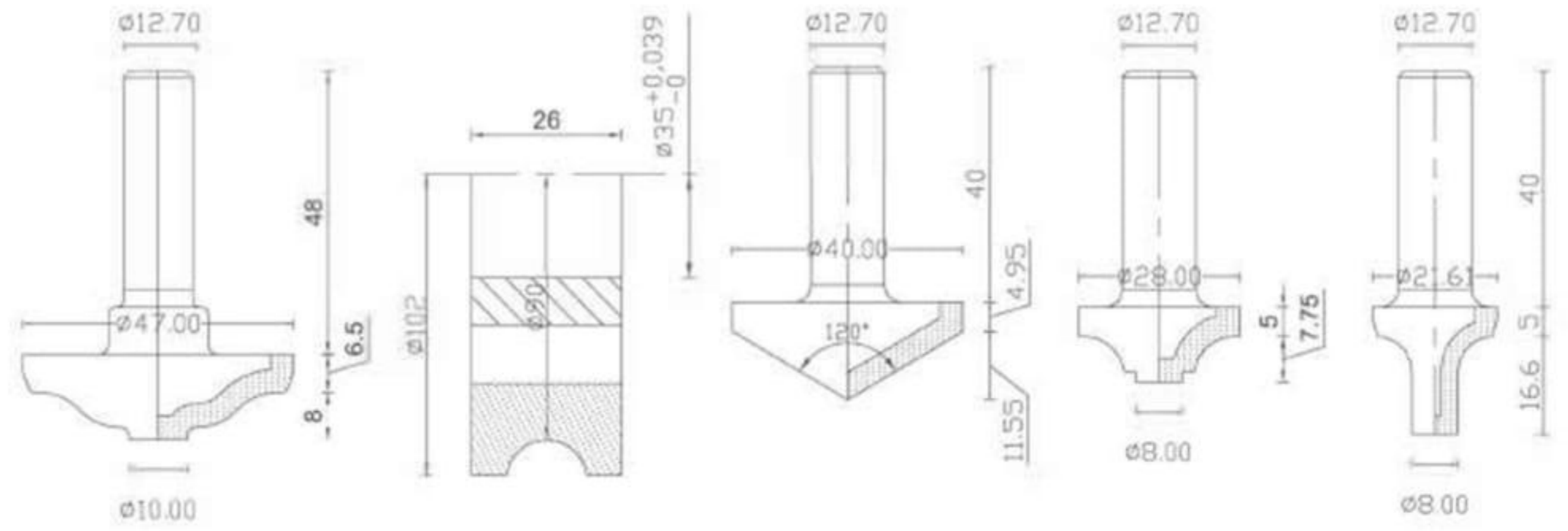

ST1174362

ST1174246

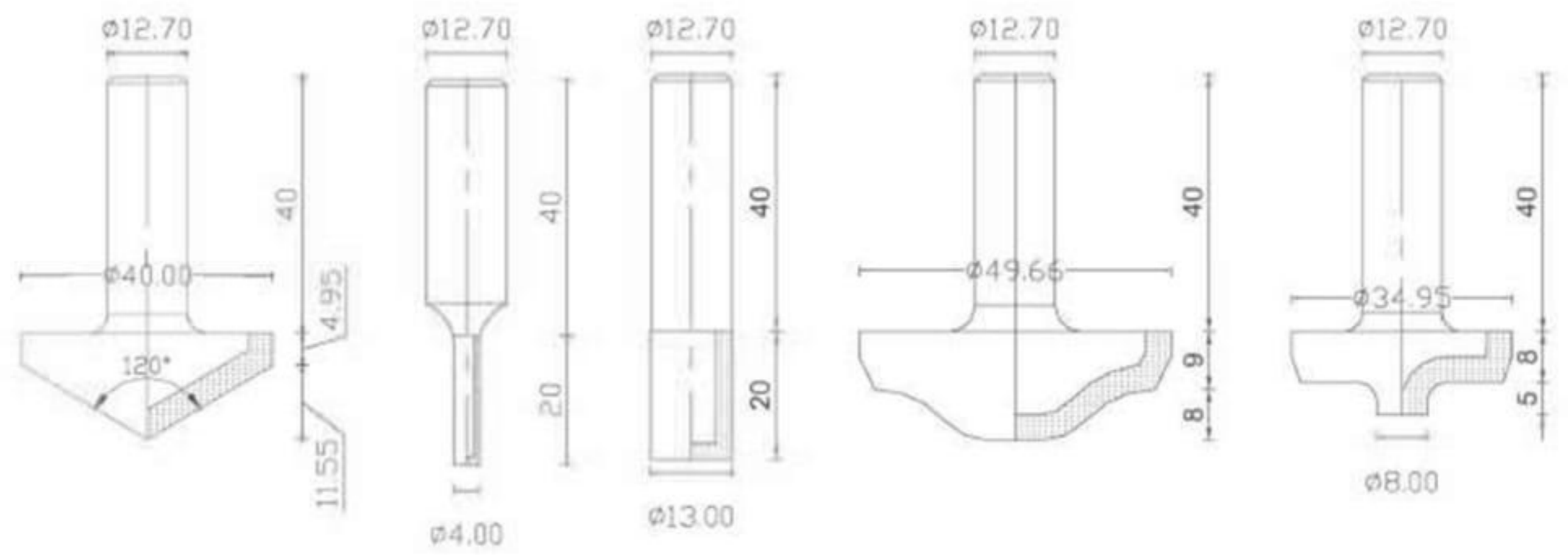

Spiral planya bıçağı - Spiral planer

Spiral tıpi planya bıçağı, her bir kesme noktasının küçük boyutlarda olmasını sağlayarak bıçak aşınmasını ve yanmasını azaltır; talaş kaldırma, malzeme çıkarma hızı hızlıdır, talaş küçük, toz yayılım hızı hızlıdır. iç ithal karbur bıçakları kullanarak, her bıçak segmentinin sertliğini ve kullanım ömrünü garanti eder.



Takım Tutucu Serisi - Toolholder Series



Adres: İkitelli OSB - Aykosan Sanayi Sitesi 4lü C Blok No:83-84 İkitelli/Başakşehir-İstanbul

Telefon: +90 (212) 637 0954 Mail: info@mefasbicak.com

Website: www.mefasbicak.com